

Closed Loop technology

Technology paper

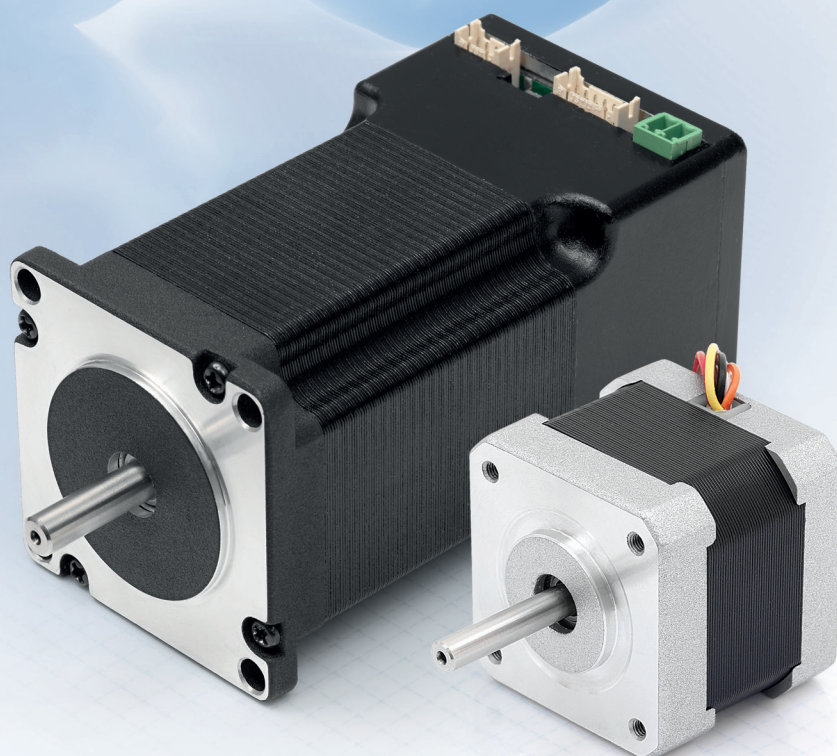

■ Closed Loop Technology

Closed-loop compatible stepper motors combine the advantages of stepper and servo motor technologies. They run more smoothly and with less resonance than stepper motors, yet they afford position feedback and control along with short transient and free oscillation times, and they do not suffer a loss of steps. Closed-loop compatible stepper motors provide an alternative to stepper motors where the situation demands

energy efficiency, smoothness and high load tolerance. Compared to servo-motors, closed-loop compatible stepper motors have advantages due to high torque at low RPM, short transient times, correct positioning without convergence, lower price, and often smaller size.

Closed loop is explained briefly here:

http://en.nanotec.com/dc_408_technology_closedloop.html

■ What is a closed loop?

The closed-loop process is also called sinusoidal commutation via encoder with field-oriented control. The heart of closed-loop technology is power-adjusted current regulation and feedback of control signals. Encoder signals report the rotor position and sinusoidal phase currents are generated in the motor windings. Vector control of the magnetic field ensures that the magnetic

field of the stator is always perpendicular to that of the rotor and that the field strength corresponds precisely to the required torque. The current regulated in this way in the windings ensures uniform motor power and extremely quiet operation of a motor that can be precisely controlled.

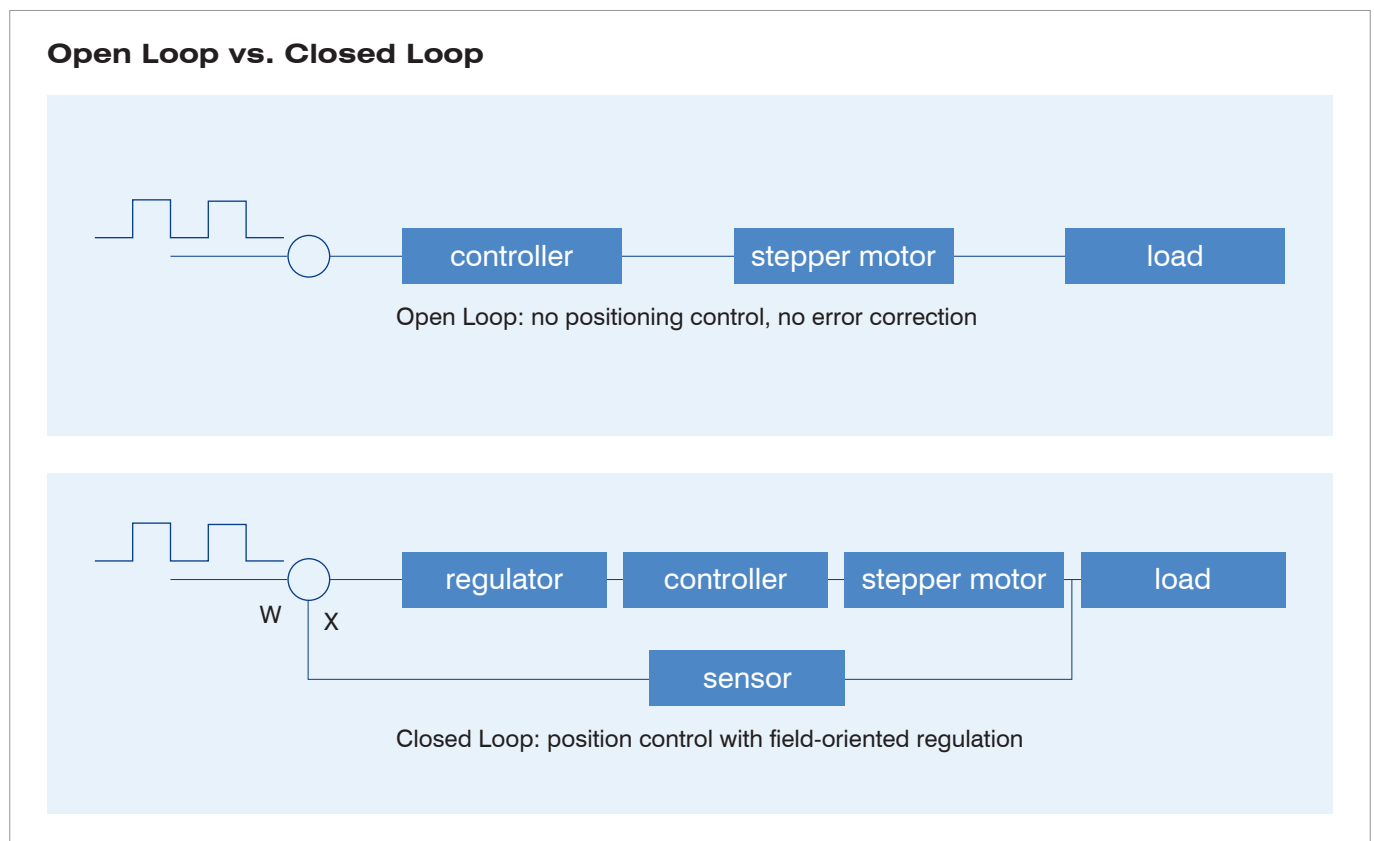

■ True vs. pseudo Closed Loop

Some stepper motors are adorned with the closed-loop label and work with encoders, yet lack field-oriented control with sinusoidal commuted current regulation. Such motors monitor only the step position, but cannot correct step angle errors during operation. A real closed-loop field-oriented control compensates for step angle errors during motion and corrects load angle errors within one full step.

Advantages over standard stepper motors

Energy efficiency

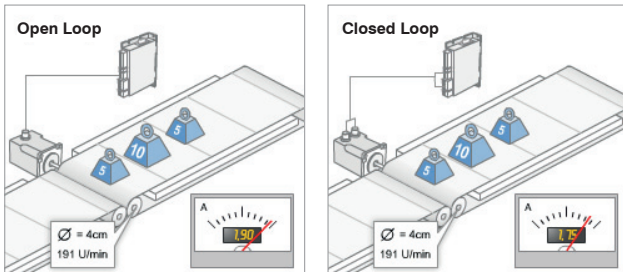

In an open-loop system, the stepper motor is dimensioned such that it is certain to move the maximum required load. For this reason, normally a safety factor of 20% is calculated, which amounts to wasted energy in the application. When the load is reduced, the open-loop motor cannot react and wastes even more energy.

Service life

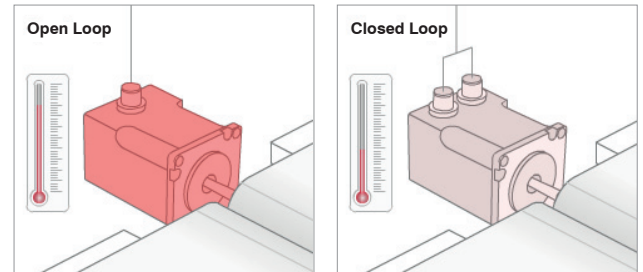

Efficient power regulation generates less heat in the motor, which stays significantly cooler. Reduced heating protects the motor bearings.

Overload

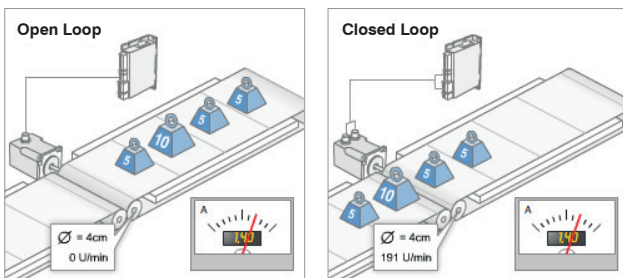

With a 20% safety reserve and a design for a continuous load of 20 kg, an additional load of only 5 kg exceeds the power reserve and the open-loop drive stops without an error message. By contrast, with its overload reserve the closed-loop stepper motor can handle this load increase easily.

Resonance behavior

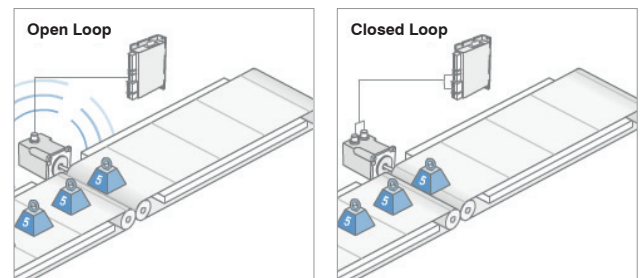

Resonance frequencies occurring in the open loop depend on external loads (the greater the torque reserve, the greater is the resonance stimulation) and can bring the motor to a stop. In closed-loop mode, the motor receives only as much energy as needed for the external load; the torque reserve and its resonance stimulation do not exist, so there is practically no resonance behavior.

Classical stepper motors are reliable, economical drives that can be used for travel to fixed positions. They operate in open-loop mode, where control signals are not fed back. The lack of position feedback is thus a limitation because, e.g., step offset or step loss due to overload is not detected.

Furthermore, lower frequencies induce more resonance behavior, and a small increase in load or a torque peak causes the motor to lose steps or fall out of synchronization or even to stop completely.

Closed Loop Stepper Motors are an advanced development of classical stepper motor technology. They eliminate the limitations and drawbacks of classical stepper motors:

- No calculation or purchase of a safety reserve (normally up to 50%) required
- Greater efficiency on load fluctuation and no stoppage on overload
- Energy-efficient operation due to intelligent current regulation
- Practically resonance-free
- Longer service life of bearings due to less heat and vibration
- Reduced acceleration time because high torque is achieved even at high RPM
- Precise positioning due to monitoring and correction

Advantages over servo-motors

Closed-loop step motors by Nanotec frequently provide an alternative to servo-drives, e.g., for winding tasks and conveyor belt operation. Not only can the rotational velocity and the position be more precisely controlled, but also (as typically required for winding applications) the torque

(torque mode). Closed-loop stepper motors combine the benefits of both worlds, achieving the greatest maximum torque, the highest efficiency and the best dynamics as well as the least torque ripple and exceptionally quiet operation.

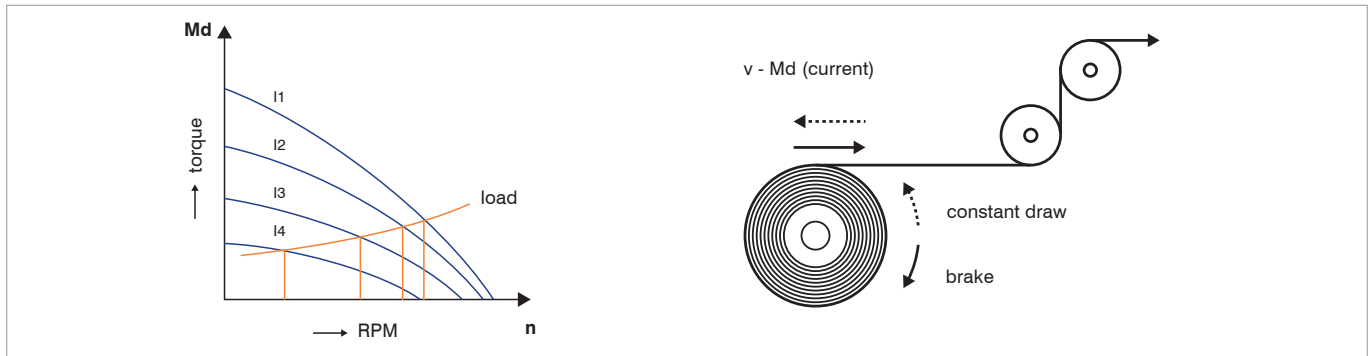

In torque mode the closed-loop stepper motor functions analogously to a spring, whereby the spring tension characteristic curve can be set via a potentiometer. Thus the motor delivers a stable force, even when the motor counteracts a force while the motor is stopped. When the force declines, the motor begins to turn proportionally to the declining force up to the current and torque setpoint values. Thus the closed-loop stepper motor proves ideal for any type of winding, stretching and pressing applications.

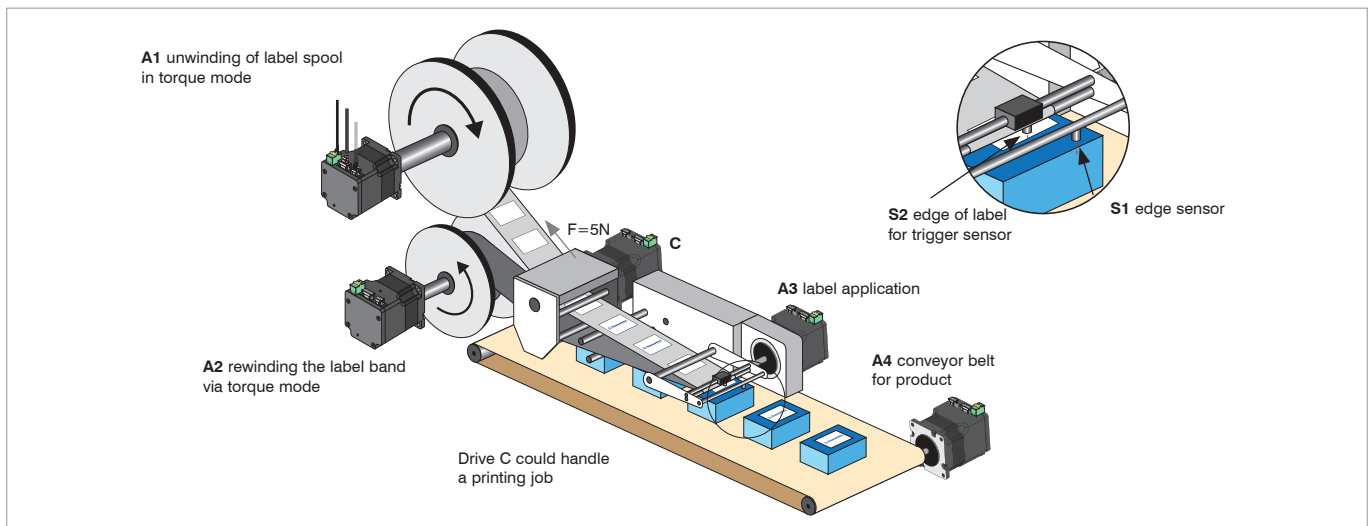

Closed-loop compatible stepper motors provide an alternative when the application requires:

- High torque at speeds up to 500 rpm and a compact, economical solution without gearbox
- Rapid commissioning without expensive tuning
- Load held in position
- Avoidance of transient and free oscillation behavior (hunting), which is typical of servo-motors and occurs especially on variable loads and pulsation, leading to intolerable step errors for the application (on sudden load changes, servo-motors miss their positions and must be corrected)

■ Ideal application domains for Closed Loop Stepper Motors

- Multiple axis applications (serial, Ethernet, EtherCAT, CANopen)
- Positioning tasks with load fluctuation
- Winding
- Conveyor belt (start/stop, positioning)
- Dosing pumps, filling systems
- Semiconductor assembly
- Wafer production
- Textile machines, industrial sewing machines
- Robotics
- Inspection systems
- Applications that require quiet operation, short transient time and precise positioning

Linear axis (for processing, assembly, etc.)

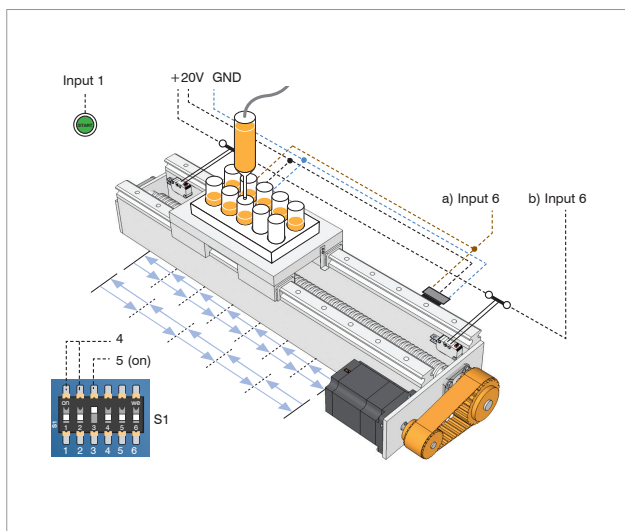

Conveyor belt

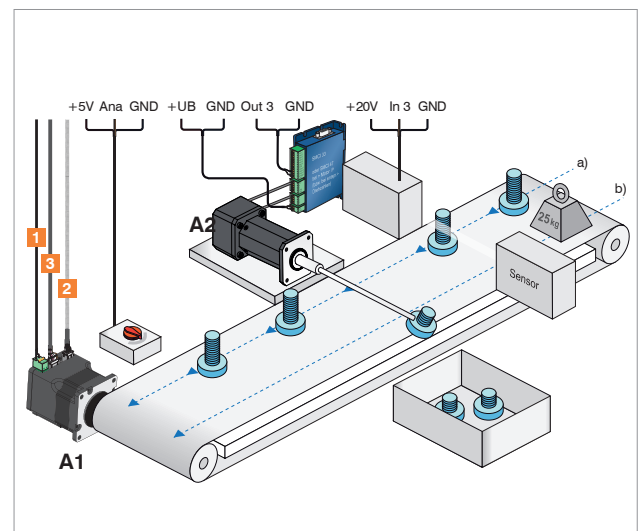

Decentralized flow regulation

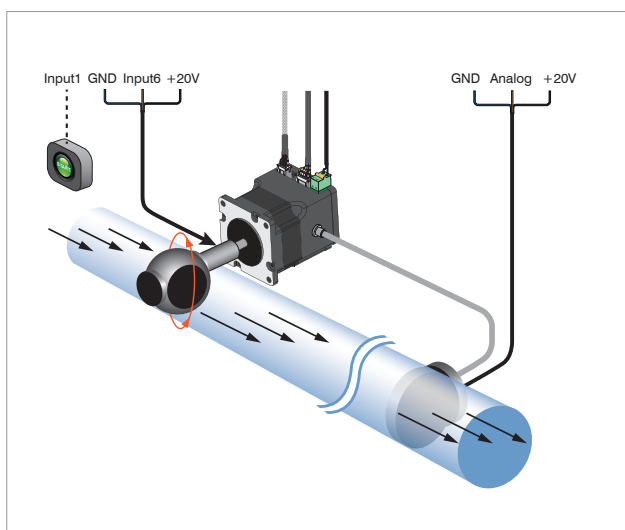

Winding and installation

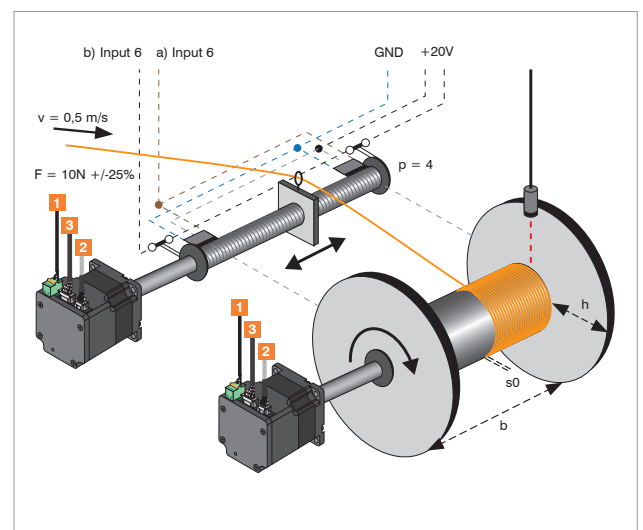

■ **Comparison (example)**

	PD4-N59 Plug & Drive stepper motor with closed loop	Servomotor DB57 with controls and gearbox
Price per motor approx.	325.00 \$	142.00 \$
Price per control approx.		203.00 \$
Price per gearbox approx.		85.00 \$
Total price	325.00 \$	430.00 \$

