

SPECIFICATION	CONNECTION	BIPOLAR PARALLEL
VOLTAGE (VDC)		2.18
AMPS/PHASE		9.5
RESISTANCE/PHASE (Ohms)@25°C		0.23±15%
INDUCTANCE/PHASE (mH) @1KHz		2.7±20%
HOLDING TORQUE (Nm) [lb-in]		9.33 [82.57]
DETENT TORQUE (Nm) [lb-in]		0.11 [0.9735]
STEP ANGLE (°) ± ACCURACY		1.8 ± 5% (NON-ACCUM)
BACK-EMF (V) (300 U/min.)		23.15
ROTOR INERTIA (Kg-m ²) [lb-in ²]		3.0x10 ⁻⁴ [1.025]
WEIGHT (Kg) [lb]		4.35 [9.59]

WIRING DIAGRAM

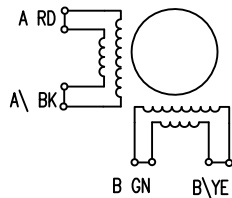

PERMISSIBLE RADIAL+AXIAL FORCE

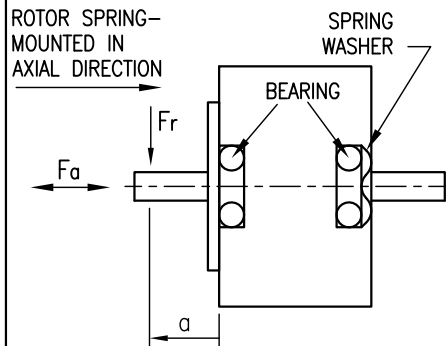

ENCODER M12		CABLE
PIN	ASSIGNMENT	COLOR
1	A	WH
2	A\	BN
3	B	GN
4	B\	YE
5	GND 0V	GY
6	I	PK
7	\	BU
8	Vcc +5V	RD
HOUSING	GND/SHIELDING	

MOTOR D-SUB-15	
PIN	ASSIGNMENT
1	A
2	A
3	A\
4	A\
5	B
6	B
7	B\
8	B\
9	NC
10	NC
11	NC
12	NC
13	NC
14	NC
15	NC
HOUSING	GND/SHIELDING

FULL STEP 2 PHASE-Ex., WHEN FACING MOUNTING END (X)

STEP	A	B	A\	B\	CCW	CW
1	+	+	-	-	↓	↑
2	-	+	+	-	↓	↑
3	-	-	+	+	↓	↑
4	+	-	-	+	↓	↑

TEMPERATURE RISE: MAX.80°C (MOTOR STANDSTILL; FOR 2 PHASE ENERGIZED)	AXIAL-FORCE Fa (N)	Fa=65			
AMBIENT TEMPERATURE -10~ 50°C [14°F ~ 122°F]	DISTANCE a (mm)	5	10	15	20
INSULATION RESISTANCE 100 MOhm (UNDER NORMAL TEMPERATURE AND HUMIDITY)	RADIAL-FORCE Fr (N)	535	355	256	200
INSULATION CLASS B 130° [266°F]			AXIAL	RADIAL	
DIELECTRIC STRENGTH 500VAC FOR 1 MIN. (BETWEEN THE MOTOR COILS AND THE MOTOR CASE)	SHAFT PLAY (mm)	0.075	0.025		
AMBIENT HUMIDITY MAX. 85% (NO CONDENSATION)	AT LOAD MAX: (N)	10	5.0		

3	COLOR OF CABLE	13.07.09	J.W.
2	PIN N RENAME AS I	24.09.07	J.W.
1	WEIGHT	04.06.07	J.W.
REV	DESCRIPTION	DATE	APVD



AD8918L9504-E

SCALE FREE	APVD	S.R.	18.04.07
X ±0.5	CHKD		
1PL ±0.2	DRN	J.W.	18.04.07
2PL ±0.1	SIGNATURE	DATE	
ANGLE ±30'			

STEPPING MOTOR

DWG.NO

AD8918L9504-E