

SPECIFICATION	CONNECTION	BIPOLAR PARALLEL
VOLTAGE (VDC)		1.75
AMPS/PHASE		6.4
RESISTANCE/PHASE (Ohms)@25°C		0.275±15%
INDUCTANCE/PHASE (mH) @1KHz		1.6±20%
HOLDING TORQUE (Nm) [lb-in]		3.2 [28.32]
DETENT TORQUE (Nm) [lb-in]		0.11 [0.9735]
STEP ANGLE (°) ± ACCURACY		1.8 ± 5% (NON-ACCUM)
BACK-EMF (V) (300 U/min.)		10.1
ROTOR INERTIA (Kg-m <sup>2</sup> ) [lb-in <sup>2</sup> ]		1.07x10 <sup>-4</sup> [0.366]
WEIGHT (Kg) [lb]		2.35 [5.18]
TEMPERATURE RISE: MAX.80°C (MOTOR STANDSTILL; FOR 2 PHASE ENERGIZED)		
AMBIENT TEMPERATURE -10~ 50°C [14°F ~ 122°F]		
INSULATION RESISTANCE 100 MOhm (UNDER NORMAL TEMPERATURE AND HUMIDITY)		
INSULATION CLASS B 130° [266°F]		
DIELECTRIC STRENGTH 500VAC FOR 1 MIN. (BETWEEN THE MOTOR COILS AND THE MOTOR CASE)		
AMBIENT HUMIDITY MAX. 85% (NO CONDENSATION)		

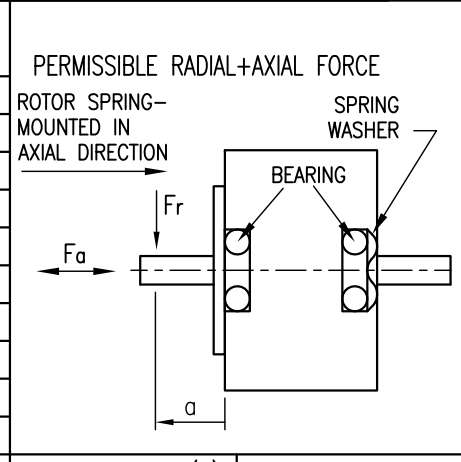

	AXIAL-FORCE Fa (N)			
	Fa=65			
DISTANCE a (mm)	5	10	15	20
RADIAL-FORCE Fr (N)	AXIAL		RADIAL	
	535	355	256	200
SHAFT PLAY (mm)	0.075		0.025	
AT LOAD MAX: (N)	10		5.0	

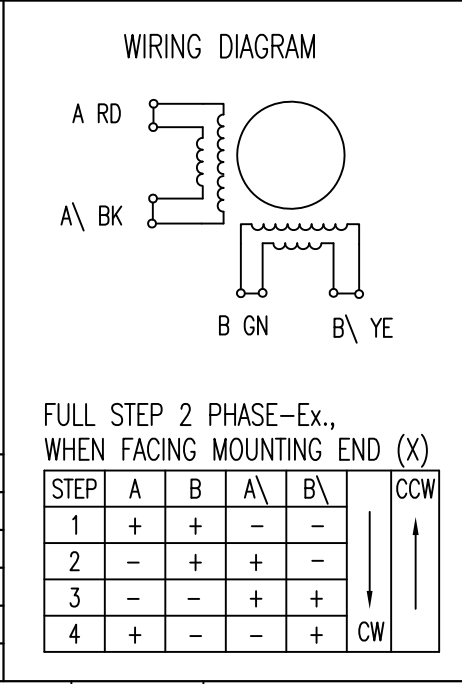

MOTOR D-SUB-15	
PIN	ASSIGNMENT
1	A
2	A
3	A\
4	A\
5	B
6	B
7	B\
8	B\
9	NC
10	NC
11	BRAKE
12	BRAKE/GND
13	NC
14	NC
15	NC
HOUSING	GND/SHIELDING

REV	DESCRIPTION	DATE	APVD	 <b>Nanotec</b> <sup>®</sup> PLUG & DRIVE	SCALE FREE	APVD	<i>S.Ha.</i>	13.03.08	<b>STEPPING MOTOR</b> DWG.NO AD8918S6404-B
					X ±0.5	CHKD			
					1PL ±0.2	DRN	<i>J.W.</i>	13.03.08	
					2PL ±0.1	SIGNATURE		DATE	
					ANGLE ±30'				