

clamp fit:  
 screw tightening torque: 4,2 Nm  
 rec. shaft length: 14,5-16,5 mm  
 max. Torque: 15 Nm

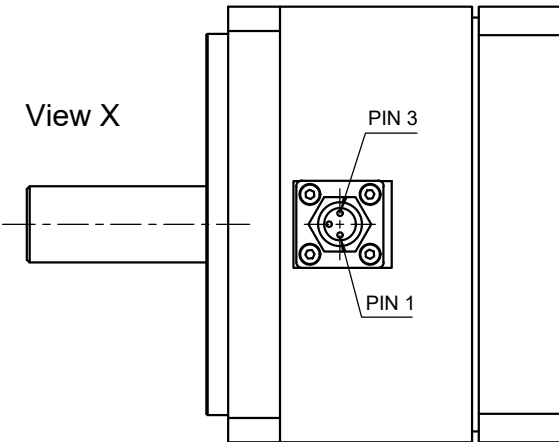
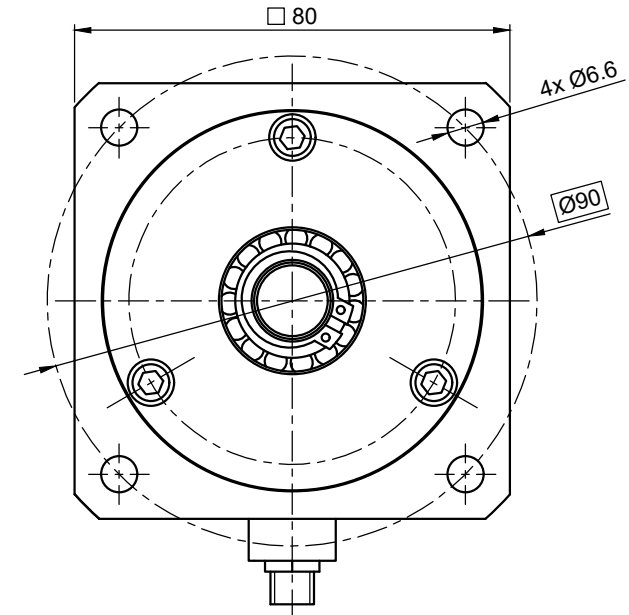

BRAKE SPECIFICATION		
Type:	<b>SPRING-LOADED BRAKE</b>	
Static Holding Torque	Nm	≥5.0
Backlash	°	<0.5
Rated Power	W	13.5
Operating Voltage	±10% V DC	24
Release Voltage	max. V DC	18
Re-Engage Voltage	min. V DC	0.5
Resistance	±7% Ω	42.7
Switch-Off Time	ms	40
Switch-On Time	ms	80
Max. Axial Force	N	50
Max. Radial Force (shaft middle)	N	150
Max. Speed	rpm	5000
Moment of Inertia	kg m <sup>2</sup>	18,7 x10 <sup>-6</sup>

PIN Assignment Brake	
PIN1	Brake+
PIN3	Brake-
PINx	n.c.

GENERAL BRAKE SPECIFICATION		
Ambient Temperature	°C	-10 ... 60
Insulation Class		F
Insulation Resistance	MΩ	100
Dielectric Strength	V AC	1500
Protection Class (except for shaft output)		IP65

ISO 8015	ISO 1302	ISO 2768 cK	ISO 13715	Weight: 1.4 kg	
			Date	Name	
			Drawn	17.05.2022	Schneid_A
			Reviewed	02.05.2023	Sejdini_B
			Released	09.05.2023	Micheli_M
REV	Rev. Text	Name	Date	<b>20001487</b> State: Released    Rev: 00    CONFIDENTIAL	

**BRAKE-BCD80-5,0-14**

