

Dimension	Tolerance
12 h7	0/ -0.018

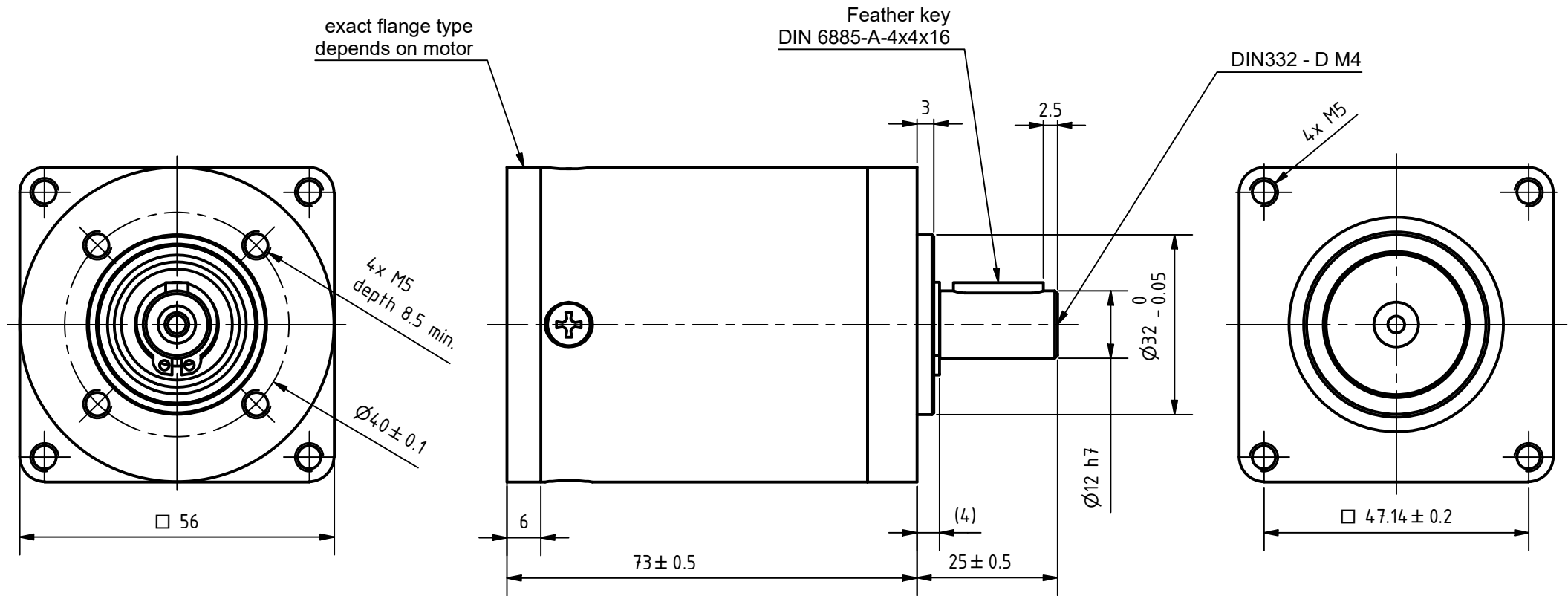

**GEARBOX SPECIFICATION**

Reduction Ratio		11(10.679)
No. of Stages		2
Rated Output Torque	Nm	6.4
Max. Output Torque	Nm	12.6
Rated Input Speed	rpm	3500
Max. Input Speed	rpm	4700
Backlash	°	0.37
Efficiency	%	86
Lifetime	h	5000
Max. Axial Force	N	1100
Max. Radial Force (shaft middle)	N	420
Gearbox Inertia	kg m <sup>2</sup>	5.6 x10 <sup>-6</sup>
Ambient Temperature	°C	-10 ... 50
Protection Class		IP54

ISO 8015	ISO 1302	ISO 2768 cK	ISO 13715	Weight: ~0.83kg		
			Date	Name		
			Drawn	17.02.2021	Schneid_A	
			Reviewed	22.02.2021	Micheli_M	
			Released	22.02.2021	Micheli_M	
00					<b>20000826</b>	Scale: 1 : 1
REV	Rev. Text	Name				Date
State: Released			Rev: 00	CONFIDENTIAL		

GP56-N2-11-SR