

Front view and mounting

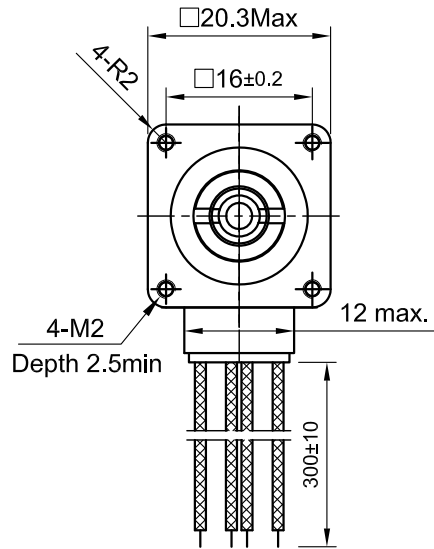

Side view

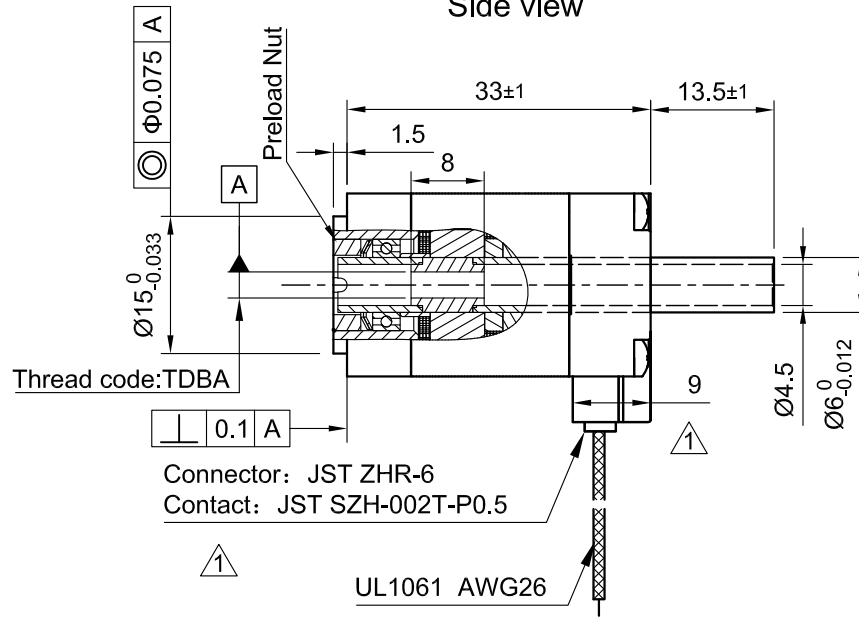

Rear view

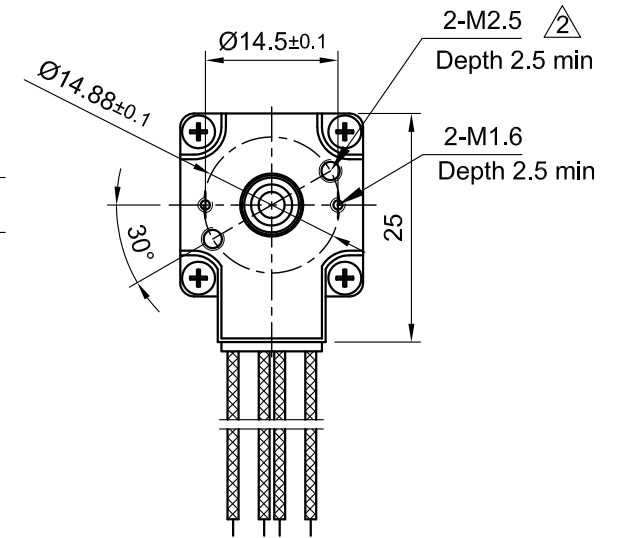

SPECIFICATION	CONNECTION	BIPOLAR
AMPS/PHASE		0.6
RESISTANCE/PHASE (Ohms)@25°C		6.4±10%
INDUCTANCE/PHASE (mH) @1KHz		2.6±20%
THREAD DIAMETER (mm) [in]		3.5 [0.138] ⚠
THREAD LEAD (mm) [in]		1 [0.0394]
THRUST (N)		46
RESOLUTION (mm/STEP)		0.005
MAX. SPEED (mm/sec.) AT 24V ⚠		40
WEIGHT (Kg) [lb]		0.054 [0.119]
TEMPERATURE RISE: MAX.80°C (MOTOR STANDSTILL; FOR 2 PHASE ENERGIZED)		
AMBIENT TEMPERATURE -10~ 50°C [14°F ~ 122°F]		
INSULATION RESISTANCE 100 MOhm (UNDER NORMAL TEMPERATURE AND HUMIDITY)		
INSULATION CLASS B 130° [266°F]		
DIELECTRIC STRENGTH 500VAC FOR 1 MIN. (BETWEEN THE MOTOR COILS AND THE MOTOR CASE)		
AMBIENT HUMIDITY MAX. 85% (NO CONDENSATION)		

Please regard the application note at www.nanotec.com for further informations.

TYPE OF CONNECTION (EXTERN)	MOTOR	
	LEADS	WINDING
BIPOLAR	BLK	A
A —	GRN	A\
B —	RED	B
B\ —	BLU	B\

FULL STEP 2 PHASE-Ex., WHEN FACING MOUNTING END (X)

STEP	A	B	A\	B\	CCW	CW
1	+	+	-	-	↓	↑
2	-	+	+	-	↓	↑
3	-	-	+	+	↓	↑
4	+	-	-	+	↓	↑

WIRING DIAGRAM

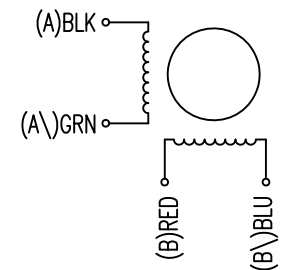

2	add 2-M2.5	01.03.19	X T		APVD	P.R.	12.03.18	LINEAR ACTUATOR
1	-	09.10.18	X T		CHKD	X T	12.03.18	
A	-	02.07.18	X T	Surface specification DIN ISO 1302	General tolerances DIN ISO 2768-cH	Work piece edge DIN ISO 13715	DRN L W 12.03.18	DWG.NO LA201S06-B-TDBA
REV	DESCRIPTION	DATE	DRN					