

Front view and mounting

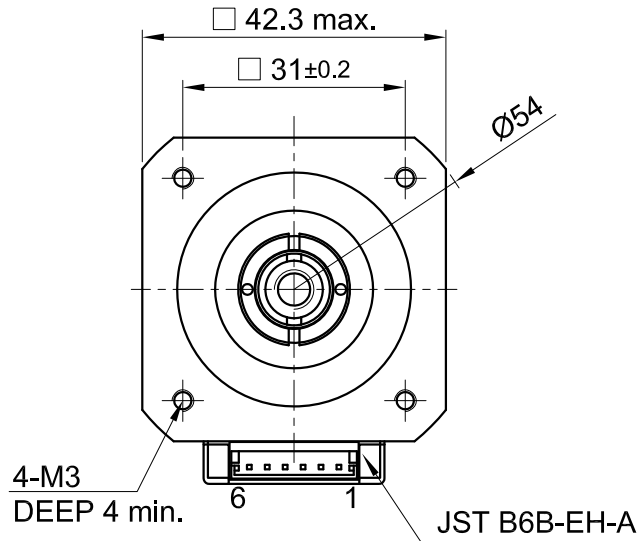

Side view

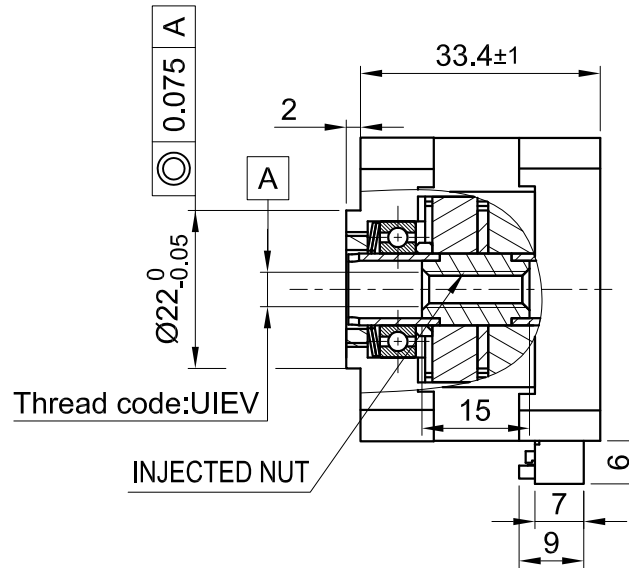

Rear view

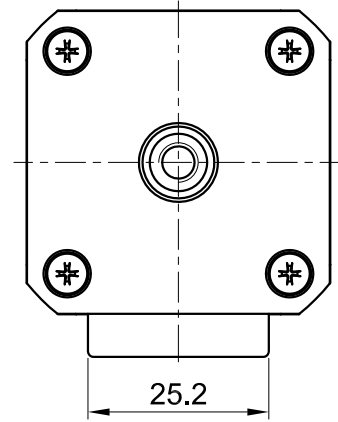

SPECIFICATION	CONNECTION	BIPOLAR
AMPS/PHASE		1.4
RESISTANCE/PHASE (Ohms)@25°C		2.0±15%
INDUCTANCE/PHASE (mH) @1KHz		2.8±20%
THREAD DIAMETER (mm) [in]		5.55625 [0.21875]
THREAD LEAD(mm) [in]		4.8768 [0.192]
THRUST (N)		232.6
RESOLUTION (mm/STEP)		0.024384
MAX. SPEED (mm/sec.) AT 24V		100
WEIGHT (Kg) [lb]		0.2 [0.44]
TEMPERATURE RISE: MAX.80°C (MOTOR STANDSTILL; FOR 2 PHASE ENERGIZED)		
AMBIENT TEMPERATURE -10~ 50°C [14°F ~ 122°F]		
INSULATION RESISTANCE 100 MOhm (UNDER NORMAL TEMPERATURE AND HUMIDITY)		
INSULATION CLASS B 130° [266°F]		
DIELECTRIC STRENGTH 500VAC FOR 1 MIN. (BETWEEN THE MOTOR COILS AND THE MOTOR CASE)		
AMBIENT HUMIDITY MAX. 85% (NO CONDENSATION)		

Please regard the application note at [www.nanotec.com](http://www.nanotec.com) for further informations.

MOTOR	
CONNECTOR PIN NO.	WINDING
1 (NC)	
2	A
3	A\
4	B
5	B\
6 (NC)	

FULL STEP 2 PHASE-Ex.,  
WHEN FACING MOUNTING END (X)

STEP	A	B	A\	B\		CCW
1	+	+	-	-	↓	↑
2	-	+	+	-		
3	-	-	+	+	↑	↓
4	+	-	-	+		

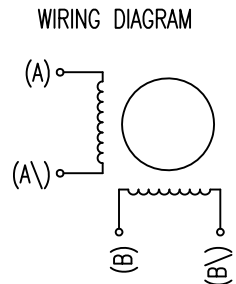

1	CHANGE MAX.SPEED	21.01.20	X T
B	-	29.05.19	X T
A	-	14.03.19	X T
REV	DESCRIPTION	DATE	DRN

**Nanotec**<sup>®</sup>  
PLUG & DRIVE

APVD	R.P.	27.07.18
CHKD	GYQ	27.07.18
DRN	X T	27.07.18
SIGNATURE		DATE

**LINEAR ACTUATOR**

DWG.NO  
**LA421S14-A-UIEV**