

Front view and mounting

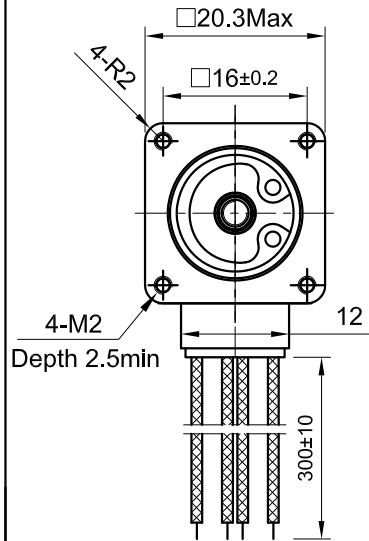

Side view

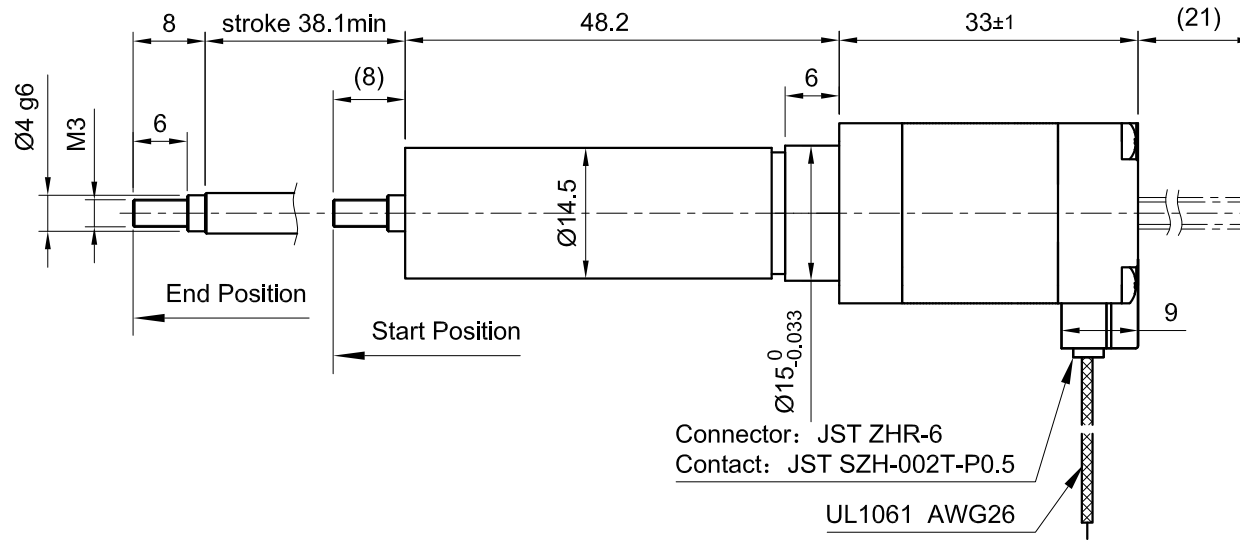

Rear view

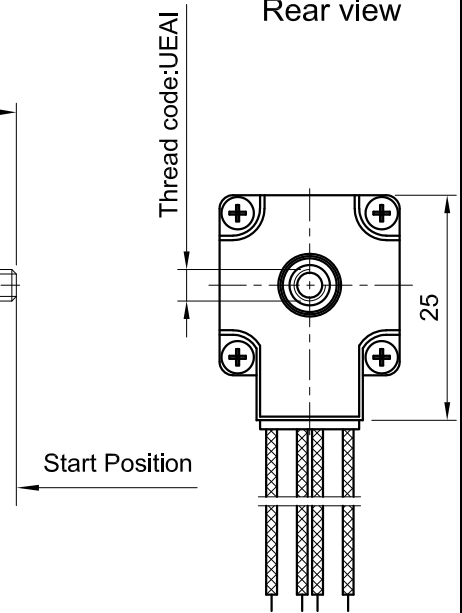

SPECIFICATION	CONNECTION	BIPOLAR
AMPS/PHASE		0.37*
RESISTANCE/PHASE (Ohms)@25°C		6.4±10%
INDUCTANCE/PHASE (mH) @1KHz		2.6±20%
THREAD DIAMETER (mm) [in]		3.5052 [0.138]
THREAD LEAD (mm) [in]		0.3048 [0.012]
RATED FORCE (N)/MAX. FORCE (N)		3 / 63
RESOLUTION (mm/STEP)		0.001524
MAX. SPEED (mm/sec.) AT 24V		5.1
WEIGHT (Kg) [lb]		0.073 [0.161]
TEMPERATURE RISE: MAX.80°C (MOTOR STANDSTILL; FOR 2 PHASE ENERGIZED)		
AMBIENT TEMPERATURE -10~ 50°C [14°F ~ 122°F]		
INSULATION RESISTANCE 100 MOhm (UNDER NORMAL TEMPERATURE AND HUMIDITY)		
INSULATION CLASS B 130° [266°F]		
DIELECTRIC STRENGTH 500VAC FOR 1 MIN. (BETWEEN THE MOTOR COILS AND THE MOTOR CASE)		
AMBIENT HUMIDITY MAX. 85% (NO CONDENSATION)		

Please regard the application note at www.nanotec.com for further informations.

* Base motor current is 0.6A.

TYPE OF CONNECTION (EXTERN)	MOTOR	
	LEADS	WINDING
BIPOLAR	BLK	A
A \ —	GRN	A \
B —	RED	B
B \ —	BLU	B \

WIRING DIAGRAM

FULL STEP 2 PHASE-Ex., WHEN FACING MOUNTING END (X)

STEP	A	B	A \	B \	CCW	CW
1	+	+	-	-	↓	↑
2	-	+	+	-	↓	↑
3	-	-	+	+	↓	↑
4	+	-	-	+	↓	↑

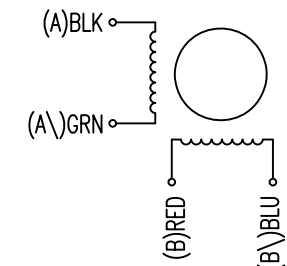

				 Nanotec [®] PLUG & DRIVE			APVD	P.R.	16.12.22	LINEAR ACTUATOR DWG.NO LGA201S06-A-UEAI-038
A	-	14.07.23	X T				CHKD	GYQ	16.12.22	
REV	DESCRIPTION	DATE	DRN	Surface specification DIN ISO 1302	General tolerances DIN ISO 2768-cH	Work piece edge DIN ISO 13715	DRN	X T	16.12.22	
							SIGNATURE	DATE		