

Front view and mounting

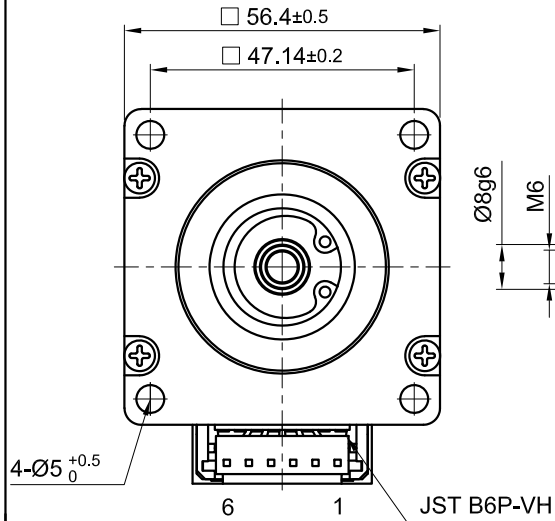

Side view

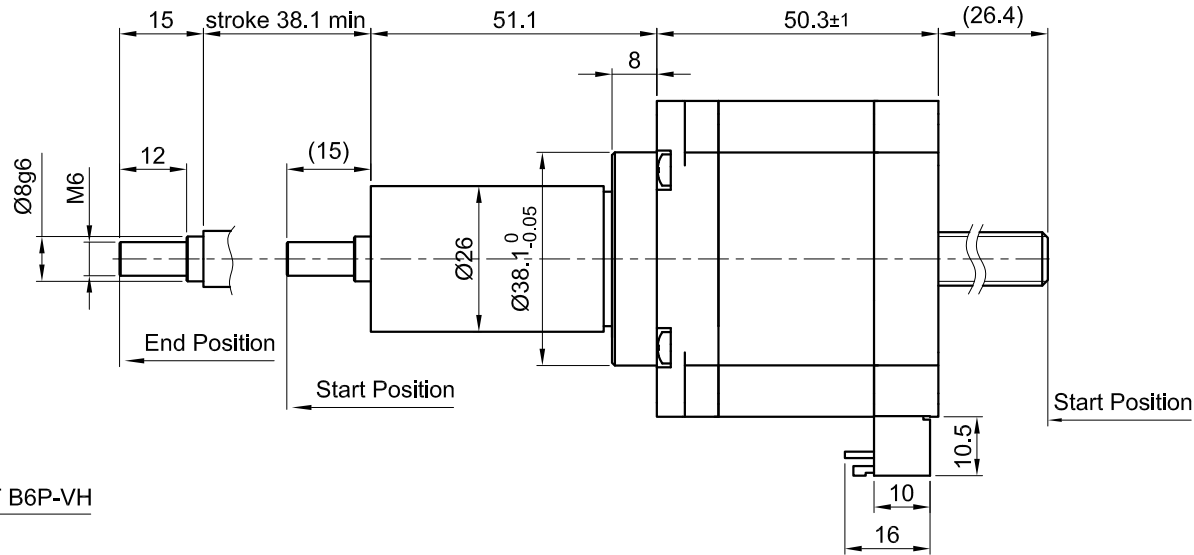

Rear view

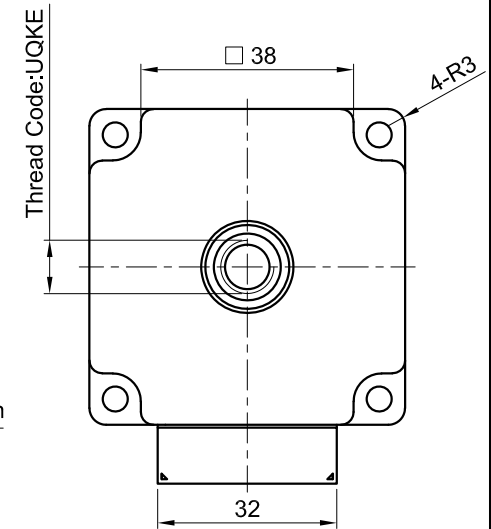

SPECIFICATION	CONNECTION	BIPOLAR
AMPS/PHASE		2.0
RESISTANCE/PHASE (Ohms)@25°C		1.5±15%
INDUCTANCE/PHASE (mH) @1KHz		4.3±20%
THREAD DIAMETER (mm) [in]		9.525 [0.375]
THREAD LEAD(mm) [in]		10.16 [0.4]
THRUST (N)		352.5
RESOLUTION (mm/STEP)		0.0508
MAX. SPEED (mm/sec.) AT 24V		150
WEIGHT (Kg) [lb]		0.75 [1.65]
TEMPERATURE RISE: MAX.80°C (MOTOR STANDSTILL; FOR 2 PHASE ENERGIZED)		
AMBIENT TEMPERATURE -10~ 50°C [14°F ~ 122°F]		
INSULATION RESISTANCE 100 MOhm (UNDER NORMAL TEMPERATURE AND HUMIDITY)		
INSULATION CLASS B 130° [266°F]		
DIELECTRIC STRENGTH 500VAC FOR 1 MIN. (BETWEEN THE MOTOR COILS AND THE MOTOR CASE)		
AMBIENT HUMIDITY MAX. 85% (NO CONDENSATION)		

Please regard the application note at www.nanotec.com for further informations.

MOTOR	
CONNECTOR PIN NO.	WINDING
1	A
3	A\
4	B
6	B\

FULL STEP 2 PHASE-Ex.,
WHEN FACING MOUNTING END (X)

STEP	A	B	A\	B\	CCW	CW
1	+	+	-	-	↓	↑
2	-	+	+	-	↓	↑
3	-	-	+	+	↓	↑
4	+	-	-	+	↓	↑

WIRING DIAGRAM

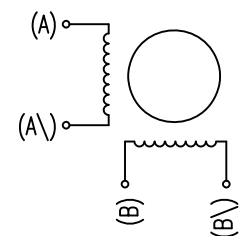

REV	DESCRIPTION	DATE	DRN	 Nanotec [®] PLUG & DRIVE			APVD	P.R.	16.05.19	LINEAR ACTUATOR DWG.NO LGA561S20-A-UQKE-038
B	-	08.01.21	X T	Surface specification DIN ISO 1302	General tolerances DIN ISO 2768-cH	Work piece edge DIN ISO 13715	CHKD	GYQ	16.05.19	
A	-	30.10.19	X T				DRN	X T	16.05.19	
							SIGNATURE	DATE		