

### Front view and mounting

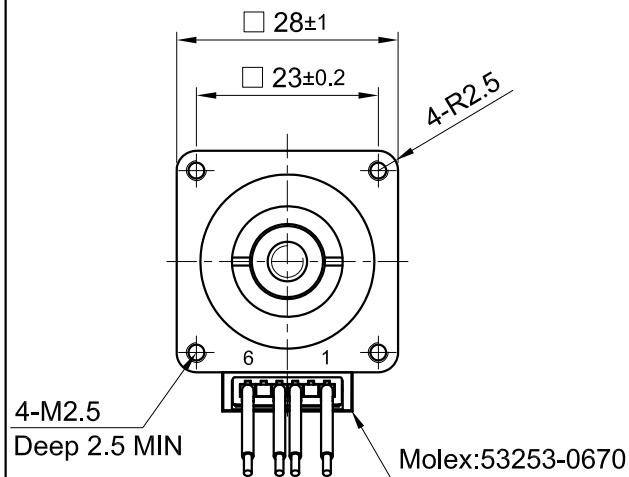

### Side view

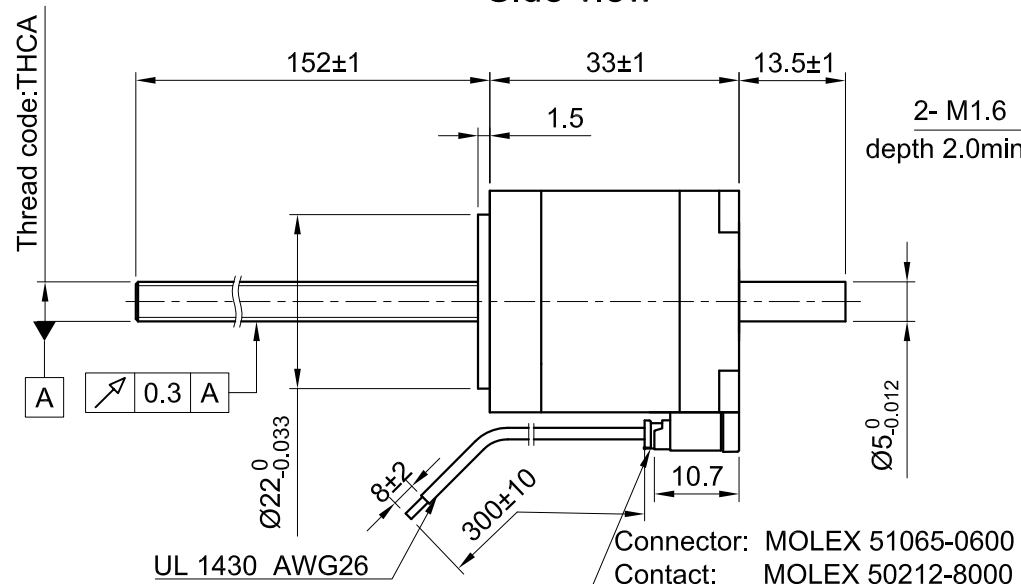

### Rear view

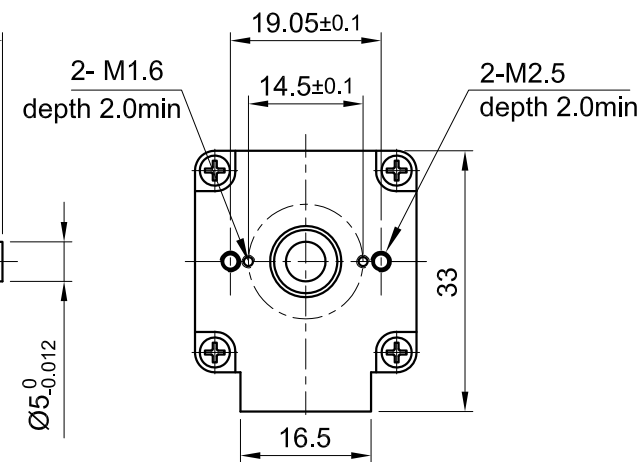

CONNECTION	BIPOLAR
SPECIFICATION	
AMPS/PHASE	1.0
RESISTANCE/PHASE (Ohms)@25°C	2.7±15%
INDUCTANCE/PHASE (mH) @1KHz	2.5±20%
THREAD DIAMETER (mm) [in]	5 [0.197]
THREAD LEAD(mm) [in]	2 [0.079]
THUST (N) [lbf]	130.7 [29.41] $\Delta$
RESOLUTION (mm/STEP)	0.01
MAX. SPEED (mm/sec.) AT 24V	40 $\Delta$
WEIGHT (Kg) [lb]	0.13 [0.29]
TEMPERATURE RISE: MAX.80°C (MOTOR STANDSTILL; FOR 2 PHASE ENERGIZED)	
AMBIENT TEMPERATURE -10°~ 50°C [14°F ~ 122°F]	
INSULATION RESISTANCE 100 MOhm (UNDER NORMAL TEMPERATURE AND HUMIDITY)	
INSULATION CLASS B 130° [266°F]	
DIELECTRIC STRENGTH 500VAC FOR 1 MIN. (BETWEEN THE MOTOR COILS AND THE MOTOR CASE)	
AMBIENT HUMIDITY MAX. 85% (NO CONDENSATION)	

Please regard the application note at [www.nanotec.com](http://www.nanotec.com) for further informations.



TYPE OF CONNECTION (EXTERN)	MOTOR		
	CONNECTOR PIN NO.	LEADS	WINDING
A —	1	BK	A
A\ —	3	GN	A\
B —	4	RD	B
B\ —	6	BU	B\

WIRING DIAGRAM

FULL STEP 2 PHASE-Ex., WHEN FACING MOUNTING END (X)

STEP	A	B	A\	B\	CCW	CW
1	+	+	-	-	↓	↑
2	-	+	+	-	↓	↑
3	-	-	+	+	↓	↑
4	+	-	-	+	↓	↑

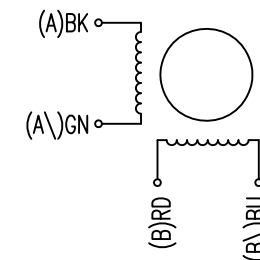

REV	DESCRIPTION	DATE	APVD	Surface specification DIN ISO 1302	General tolerances DIN ISO 2768-CH	Work piece edge DIN ISO 13715	APVD	P.R.	24.07.18	DWG.NO
2	Change thrust and Max.speed	16.12.19	X T				CHKD	GYQ	24.07.18	
1	Remove shaft play adjustable	11.03.19	X T	DRN	X T	24.07.18				
B	-	31.01.19	X T	SIGNATURE		DATE	LSA281S10-B-THCA-152			