

Front view and mounting

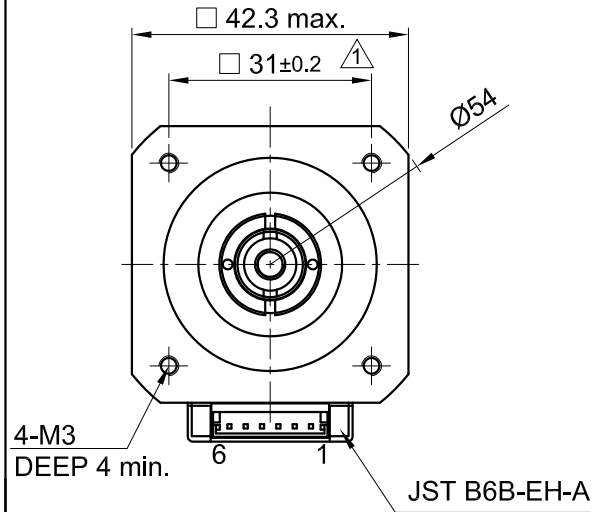

Side view

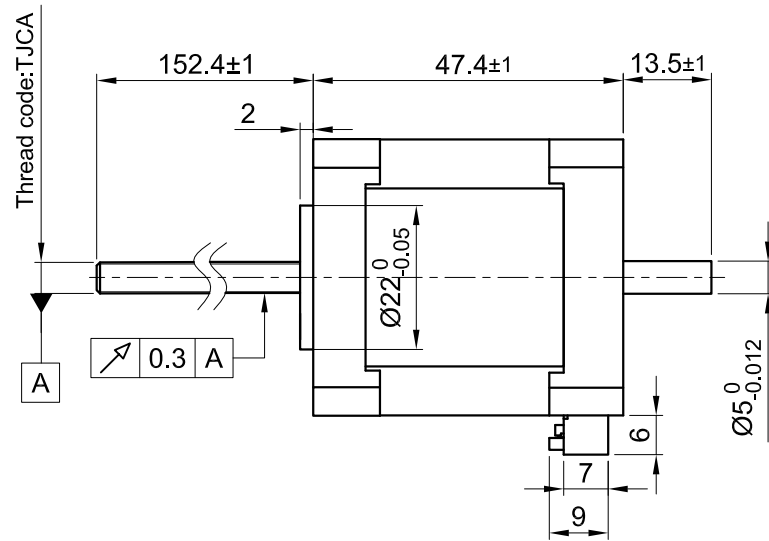

Rear view

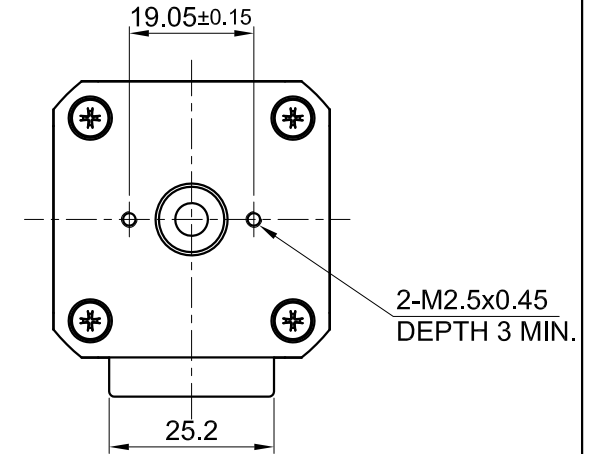

SPECIFICATION	CONNECTION	BIPOLAR
AMPS/PHASE		1.8
RESISTANCE/PHASE (Ohms)@25°C		1.75±15%
INDUCTANCE/PHASE (mH) @1KHz		3.4±20%
THREAD DIAMETER (mm) [in]	1	6 [0.236]
THREAD LEAD(mm) [in]		2 [0.078]
THRUST (N)		369
RESOLUTION (mm/STEP)		0.01
MAX. SPEED (mm/sec.) AT 24V		50
WEIGHT (Kg) [lb]		0.4 [0.88]
TEMPERATURE RISE: MAX.80°C (MOTOR STANDSTILL; FOR 2 PHASE ENERGIZED)		
AMBIENT TEMPERATURE -10~ 50°C [14°F ~ 122°F]		
INSULATION RESISTANCE 100 MOhm (UNDER NORMAL TEMPERATURE AND HUMIDITY)		
INSULATION CLASS B 130° [266°F]		
DIELECTRIC STRENGTH 500VAC FOR 1 MIN. (BETWEEN THE MOTOR COILS AND THE MOTOR CASE)		
AMBIENT HUMIDITY MAX. 85% (NO CONDENSATION)		

Please regard the application note at www.nanotec.com for further informations.

MOTOR	
CONNECTOR PIN NO.	WINDING
1 (NC)	
2	
3	
4	
5	
6 (NC)	

FULL STEP 2 PHASE-Ex.,
WHEN FACING MOUNTING END (X)

STEP	A	B	A\	B\		CCW
1	+	+	-	-		
2	-	+	+	-		
3	-	-	+	+		
4	+	-	-	+		

WIRING DIAGRAM

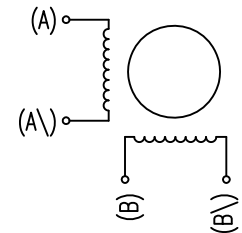

REV	DESCRIPTION	DATE	DRN	 Nanotec [®] PLUG & DRIVE			APVD	A.N.	10.11.17	LINEAR ACTUATOR DWG.NO LSA421L18-B-TJCA-152
1	Adjust the parameters	18.03.19	X T	Surface specification DIN ISO 1302	General tolerances DIN ISO 2768-cH	Work piece edge DIN ISO 13715	CHKD	GYQ	10.11.17	
A	-	22.01.18	L W				DRN	L W	10.11.17	
							SIGNATURE		DATE	