

<b>X1</b>	<b>EtherCAT IN</b>
	<b>M12 / 4-Pole / D-Coding / female</b>

<b>X2</b>	<b>EtherCAT OUT</b>
	<b>M12 / 4-Pole / D-Coding / female</b>
Pin No.	Function
1	TD+
2	RD+
3	TD-
4	RD-
cable shield on housing	

<b>X3</b>	<b>POWER</b>
	<b>M12 / 5-Pole / B-Coding / male</b>
Pin No.	Function
1	+UB
2	+UB
3	GND
4	GND
5	n.c.
cable shield on housing	

<b>X4</b>	<b>IO</b>
	<b>M12 / 12-Pole / A-Coding / male</b>
Pin No.	Function
1	GND
2	Input 1 (+5V/+24V)
3	Input 2 (+5V/+24V)
4	Input 3 (+5V/+24V)
5	Input 4 (+5V/+24V)
6	Input 5 (+5V/+24V)
7	Input 6 (+5V/+24V)
8	Analog Input (0-10V/0-20mA)
9	Output 1 (open drain)
10	Output 2 (open drain)
11	+5V Voltage Supply (max. 100mA)
12	+UB Logic (24V)
cable shield on housing	

MOTOR SPECIFICATION	
No. of Poles	6
Rated Voltage	V DC 48
Operating Voltage - Min. / Max.	V DC 12 / 48
Current - Rated / Peak	A 6 / 18
Torque - Rated / Peak	Nm 0.6 / 1.8
Torque Constant	Nm/A 0.1
Power - Rated / Peak	W 220 / 660
Speed - No Load / Rated	±10% rpm 4500 / 3500
Operating Voltage Encoder	V DC 5
Encoder Resolution	cpr 1024
Encoder Resolution (cpr with quadrature)	ppr 4096
Encoder Signal Type	incremental
Rotor Inertia	kg m <sup>2</sup> 17.3 x10 <sup>-6</sup>

GENERAL MOTOR SPECIFICATION	
Interface	ETHERCAT
Ambient Temperature	°C -10 ... 40
Max. Ambient Humidity (non condensing)	% 85
Insulation Class	B
Insulation Resistance	MΩ 100
Dielectric Strength (for 1 min - coil to case)	V AC 500
Protection Class (except shaft outlet)	IP65

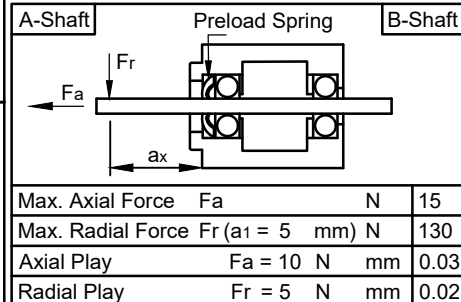
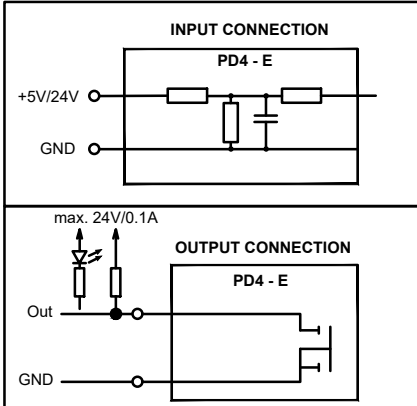

ISO 8015	ISO 1302	ISO 2768 cK	ISO 13715
03	additional dimension	Reith_S	15.02.2024
02	unification PD4 -GM	Schneid_A	25.03.2021
01	change weight	Schneid_A	21.01.2021
REV	Rev. Text	Name	Date

Weight: ±10% 1.4	kg
<b>PD4-EB59CD-E-65-1</b>	
09000008	
State: Released	Rev: 03
CONFIDENTIAL	

