

SPECIFICATION	CONNECTION	BIPOLAR
VOLTAGE (VDC)		12 TO 48
AMPS/PHASE		4.2 A
THREAD DIAMETER (mm) [in]		9.525 [0.375]
THREAD LEAD(mm) [in]		1.5875 [0.0625]
THRUST (N)		1023.5
RESOLUTION (mm/STEP)		0.008
MAX. SPEED (mm/sec.) AT 48V		39.7
WEIGHT (Kg) [lb]		0.95 [2.09]

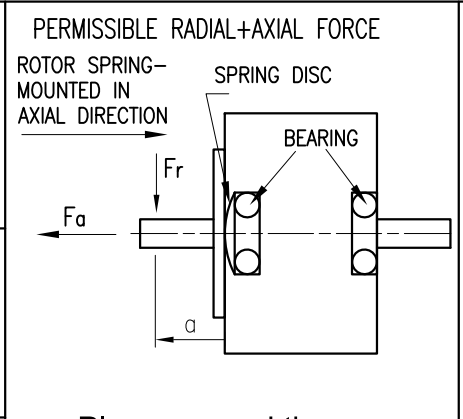
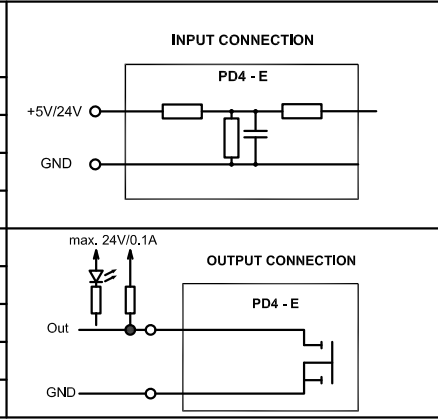

X1 EtherCAT IN (M12, 4-Pole, D-coding, female)		X4 IO (M12, 12-Pole, A-coding, male)	
Pin No.		Function	
1		GND	
2		Input 1 (+5V/+24V)	
3		Input 2 (+5V/+24V)	
4		Input 3 (+5V/+24V)	
5		Input 4 (+5V/+24V)	
6		Input 5 (+5V/+24V)	
7		Input 6 (+5V/+24V)	
8		Analog Input (0-10V/0-20mA)	
9		Output 1 (open drain)	
10		Output 2 (open drain)	
11		+5V Voltage Supply (max. 100mA)	
12		+UB Logic (24V)	

X2 EtherCAT OUT (M12, 4-Pole, D-coding, female)	
Pin No.	Function
1	TD+
2	RD+
3	TD-
4	RD-

X3 Power (M12, 5-Pole, B-coding, male)	
Pin No.	Function
1	+UB (12-48V)
2	+UB (12-48V)
3	GND
4	GND
5	N.C.

Please regard the application note at www.nanotec.com for further informations.

				 Nanotec [®] PLUG & DRIVE			APVD	<i>P.R.</i>	01.02.23	PLUG&DRIVE MOTOR	
							CHKD	<i>GYQ</i>	01.02.23		
REV				DESCRIPTION			DATE			DWG.NO	
				Surface specification DIN ISO 1302	General tolerances DIN ISO 2768- cH	Work piece edge DIN ISO 13715			PSA56S-E-1-VQBN-152		