

Front view and mounting

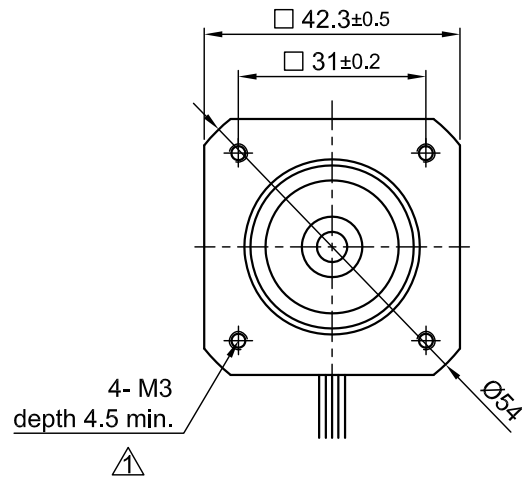

Side view

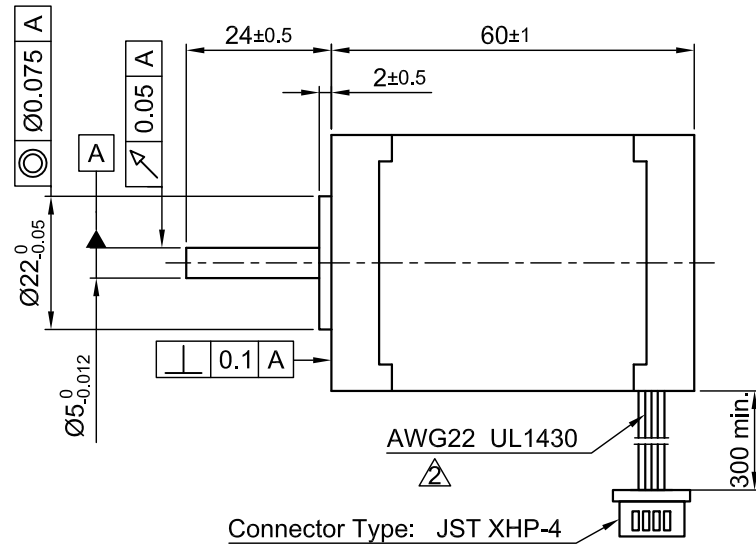

Rear view

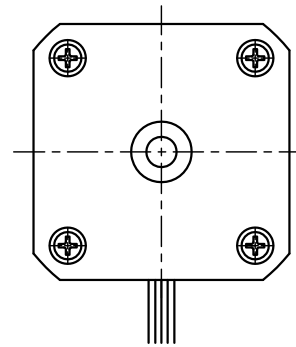

SPECIFICATION	BIPOLAR
VOLTAGE (VDC)	3.3
AMPS/PHASE	3.0
RESISTANCE/PHASE (Ohms)@25°C	1.1±15%
INDUCTANCE/PHASE (mH) @1KHz	2.7±20%
HOLDING TORQUE (Nm) [lb-in]	0.8 [7.08]
DETENT TORQUE (Nm) [lb-in]	2.8x10 ⁻² [0.25]
STEP ANGLE (°)	1.8
STEP ACCURACY (NON-ACCUM)	±5%
ROTOR INERTIA (Kg-m ²) [lb-in ²]	1.02x10 ⁻⁵ [3.48x10 ⁻²]
WEIGHT (Kg) [lb]	0.5 [1.1]

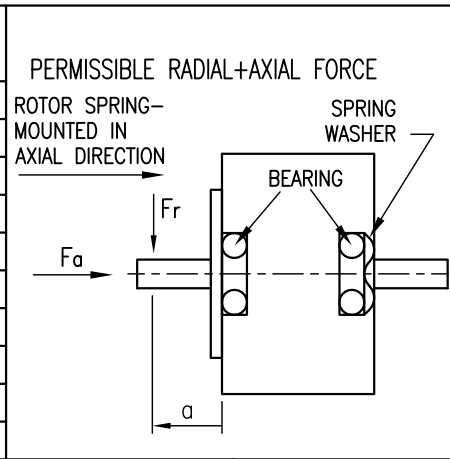

PIN NO	TYPE OF CONNECTION (EXTERN)		MOTOR	
	BIPOLAR	LEADS	WINDING	
1	A —	BRN	A	
2	A \ —	ORG	A \	
3	B —	RED	B	
4	B \ —	YEL	B \	

TEMPERATURE RISE: MAX.80°C (MOTOR STANDSTILL; FOR 2 PHASE ENERGIZED)	AXIAL-FORCE Fa (N)	Fa=7			
AMBIENT TEMPERATURE -10~ 50°C [14°F ~ 122°F]	DISTANCE a (mm)	5	10	15	20
INSULATION RESISTANCE 100 MOhm (UNDER NORMAL TEMPERATURE AND HUMIDITY)	RADIAL-FORCE Fr (N)	58	36	26	20
INSULATION CLASS B 130° [266°F]		AXIAL		RADIAL	
DIELECTRIC STRENGTH 500VAC FOR 1 MIN. (BETWEEN THE MOTOR COILS AND THE MOTOR CASE)	SHAFT PLAY (mm)	0.08		0.02	
AMBIENT HUMIDITY MAX. 85% (NO CONDENSATION)	AT LOAD MAX: (N)	4.5		4.5	

FULL STEP 2 PHASE-Ex., WHEN FACING MOUNTING END (X)

STEP	A	B	A \	B \	CCW	CW
1	+	+	-	-	↓	↑
2	-	+	+	-	↓	↑
3	-	-	+	+	↓	↑
4	+	-	-	+	↓	↑

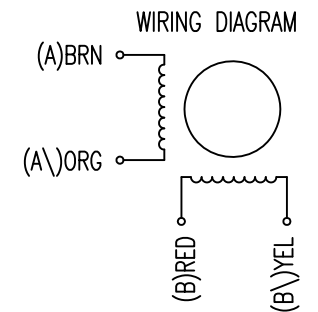

2	change AWG	23.06.16	A.S.				APVD	S.Ha.	17.03.10	STEPPING MOTOR
1	rework draw/change depth M3	10.02.16	A.S.				Surface specification DIN ISO 1302	General tolerances DIN ISO 2768- cH	Work piece edge DIN ISO 13715	
REV	DESCRIPTION	DATE	DRN				DRN	J.W.	17.03.10	ST4118D3004-A
							SIGNATURE	DATE		