

A-A

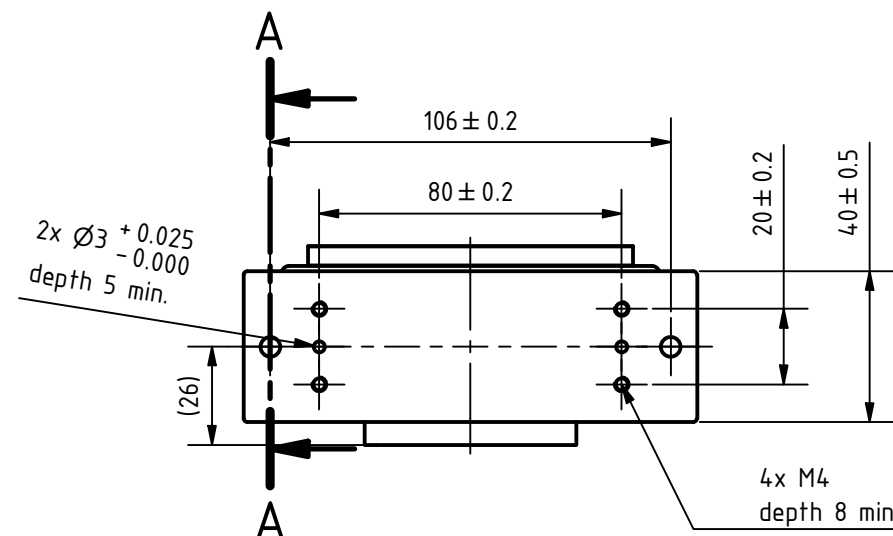

WHEEL DRIVE SPECIFICATION	
Reduction Ratio	16 (15.51)
No. of Stages	2
Rated Output Torque	Nm 24.6
Max. Output Torque	Nm 39.4
Rated Input Speed	rpm 3,500
Max. Input Speed	rpm 5,968
Backlash	° 0.53
Efficiency	% 94
Load Capacity	kg 400
Inertia	kg m <sup>2</sup> 11.3x10 <sup>-6</sup>
Wheel Material	Lmax (polyurethane)
Ambient Temperature	°C -15...90
Protection Class	IP54

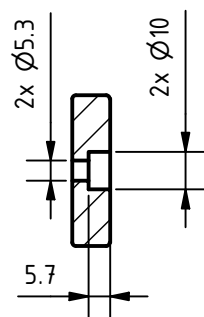

ISO 8015	ISO 1302	ISO 2768 mH	ISO 13715	Weight: 1.6kg	
			Date	Name	
			Drawn	11.02.2019	Naubert_A
03	Load capacity updated	Micheli_M	02.04.2020	Reviewed	01.03.2019
02	Specifications updated	Micheli_M	30.03.2020	Released	01.03.2019
01	Internal changes		30.03.2020		
REV	Rev. Text	Name	Date		
				State: Released	Rev: 03
				CONFIDENTIAL	Scale: 1 : 2
				A3 Page 1	

WD10030-5616-23B



06000098  
State: Released  
Rev: 03  
CONFIDENTIAL