

User Manual

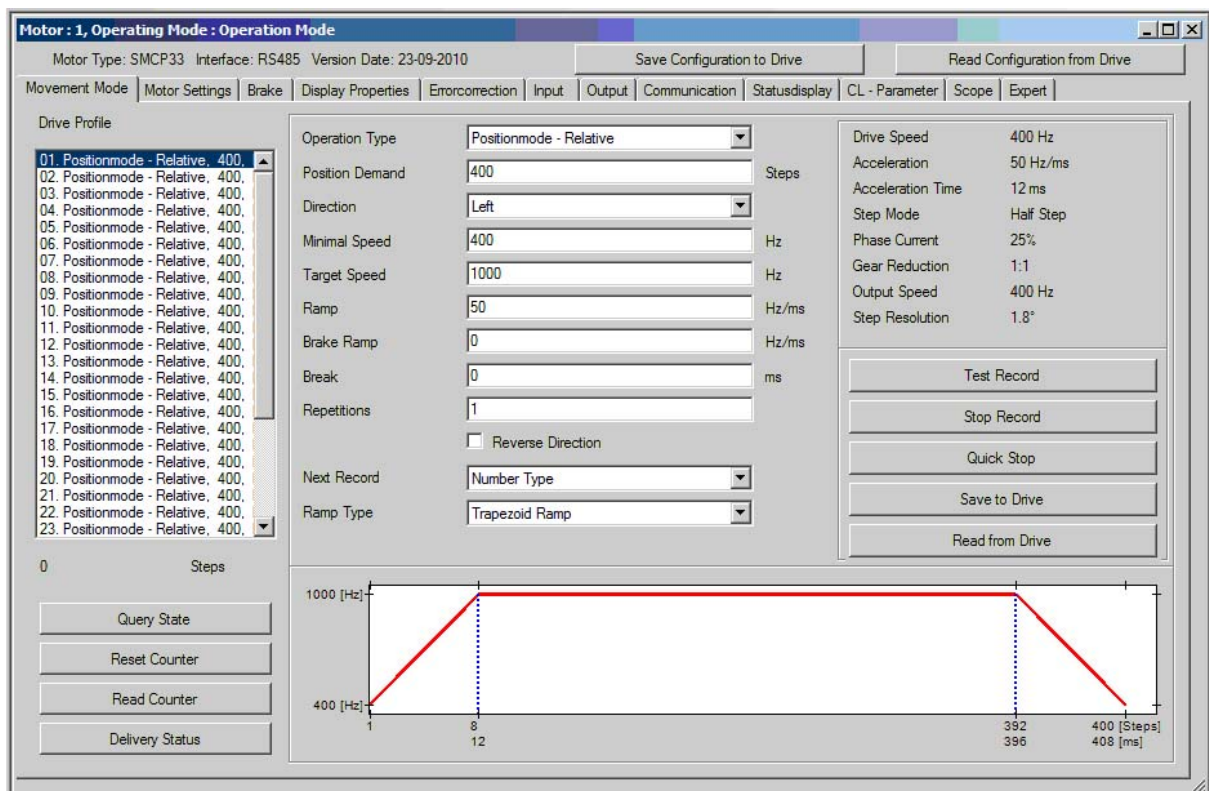

NanoPro Control software for stepper motor controllers and Plug & Drive motors (valid from version 1.7.0.0)

NANOTEC ELECTRONIC GmbH & Co. KG
Kapellenstraße 6
D-85622 Feldkirchen b. Munich, Germany

Tel. +49 (0)89-900 686-0
Fax +49 (0)89-900 686-50
info@nanotec.com

Editorial

© 2013

Nanotec[®] Electronic GmbH & Co. KG

Kapellenstraße 6

D-85622 Feldkirchen b. Munich, Germany

Tel.: +49 (0)89-900 686-0

Fax: +49 (0)89-900 686-50

Internet: www.nanotec.com

All rights reserved!

MS-Windows 2000/XP/Vista/7 are registered trademarks of the Microsoft Corporation.

Translation of original handbook

Version/Change overview

Version	Date	Changes
1.0	03.06.2009	New issue
2.0	01.10.2009	Revision of the new software release for version 1.52.09
2.1	05.11.2010	Revision of the new software release for version 1.60.0.0
2.2	03.11.2011	Revision of the new software release for version 1.7.0.0
2.3	25.06.2013	Revision

About this manual

Target group

This user manual is aimed at designers and developers who need to configure one of the Nanotec SMC112, SMC133, SMC135, SMC136, SMC147-S-2, SMCP33 stepper motor controllers or a Plug & Drive motor of the PDx-N series[®] with the aid of the NanoPro control software without much experience of stepper motor technology.

Important information

This manual only contains a description of the NanoPro control software, version 1.7.0.0 or later.



For the connection and the commissioning of stepper motor controllers or Plug & Drive motors, see the respective technical manuals!

Nanotec[®] reserves the right to make technical alterations and further develop hardware and software in the interests of its customers to improve the function of this product without prior notice.

For criticisms, proposals and suggestions for improvement, please contact the above address or send an email to: info@nanotec.com

Additional manuals

Please also note the following manuals from Nanotec:

<p>Programming manual</p>	<p>Control programming</p> <ul style="list-style-type: none"> • Command reference • NanoJ • COM interface 	
<p>NanoCAN User Manual</p>	<p>Configuration of the CAN communication for CANopen-capable controllers with the NanoCAN software</p>	
<p>Nanotec CANopen reference</p>	<p>Comprehensive documentation of the CANopen functions</p>	
<p>Technical manuals</p>	<p>Connection and commissioning of stepper motor controllers or Plug & Drive motors</p>	

The manuals are available for download at www.nanotec.com.

Contents

Editorial.....	2
About this manual.....	3
Contents	5
1 Installation	7
2 Overview of the user interface.....	8
2.1 General information.....	8
2.2 Subdivision of the user interface.....	8
2.2.1 The menu bar.....	8
2.2.2 The menu window	11
3 Configuring the controller.....	12
4 <Mode> tab	13
4.1 Overview	13
4.2 Entering the profile parameters.....	15
4.3 Relative and absolute positioning, internal and external reference run.....	19
4.3.1 Description	19
4.3.2 Assignment of the inputs and outputs.....	20
4.3.3 Profile parameters.....	21
4.3.4 Signal curves.....	24
4.4 Speed Mode.....	24
4.4.1 Description	25
4.4.2 Assignment of the inputs and outputs.....	26
4.4.3 Profile parameters.....	26
4.4.4 Signal curves in the Speed Mode	27
4.5 Flag Positioning Mode.....	27
4.5.1 Description	28
4.5.2 Assignment of the inputs and outputs.....	29
4.5.3 Profile parameters.....	29
4.5.4 Signal curves in the Flag Positioning Mode.....	31
4.6 Clock-Direction Mode Int. Ref./Ext. Ref. / Left/Right.....	31
4.6.1 Description	32
4.6.2 Assignment of the inputs and outputs.....	32
4.6.3 Profile parameters.....	33
4.6.4 Signal curves in the Clock-Direction Mode	34
4.7 Analog and Joystick Mode	34
4.7.1 Description	35
4.7.2 Assignment of the inputs and outputs.....	35
4.7.3 Profile parameters.....	36
4.8 Analogue Positioning Mode	37

4.8.1	Description	37
4.8.2	Assignment of the inputs and outputs.....	37
4.8.3	Profile parameters.....	38
4.9	Torque mode.....	39
5	<Motor settings> tab.....	40
6	<Brake> tab.....	45
7	<Display Settings> tab	47
8	<Errorcorrection> tab	48
9	<Inputs> tab.....	51
10	<Outputs> tab.....	58
11	<Communication> tab	60
12	<Status display> tab	62
13	<CL-Parameter> tab (closed loop)	64
13.1	Configuring the closed loop current control	64
13.2	Velocity loop.....	65
13.3	Position loop.....	66
14	<Scope> tab.....	77
15	<Expert> tab	80
16	Operating multiple motors	84
17	Troubleshooting.....	85
17.1	General information.....	85
17.2	Error messages.....	86
Index.....		88

1 Installation

System requirements

- MS-Windows 2000/XP/Vista/Windows 7
- Free COM port on your Windows PC

Procedure

To install the NanoPro control software on your PC, you must first download the software from the Nanotec website.

To do this, proceed as follows:

Step	Action
1	Open the Nanotec website at http://www.nanotec.com in your browser.
2	Go to the "Downloads" area and select the following software: "Windows Software NanoPro for Plug & Drive & SMCI (NEW) >>"
3	Download the "NanoPro V xxx.zip" file onto your PC.
4	Unpack the zip file on your PC in the required directory.
5	Open the "NanoPro V xxx" folder and start the setup program by double-clicking on the "Setup_xxx.exe" file.
6	Follow the installation instructions of the setup program.

2 Overview of the user interface

2.1 General information

Introduction

The SMCI12, SMCI33, SMCI35, SMCI36, SMCI47-S-2, SMCP33 stepper motor controllers and Plug & Drive motors of the PDx-N series can be configured and programmed with the NanoPro control software using any standard Windows PC.

Transparent interfaces and simple test functions enable rapid entry into operation and programming and facilitate commissioning.

Due to the straightforward operating interface, not all functions are described in this manual. Much of it is self-explanatory. Therefore, only a few essential operational procedures are explained.

Familiarize yourself with the operating interface of the NanoPro control software before starting to commission and program the stepper motor controllers or Plug & Drive motors.

2.2 Subdivision of the user interface

Menu bar and menu window

The operating interface is basically set up with a menu bar (1) and a separate menu window (2) for each motor.

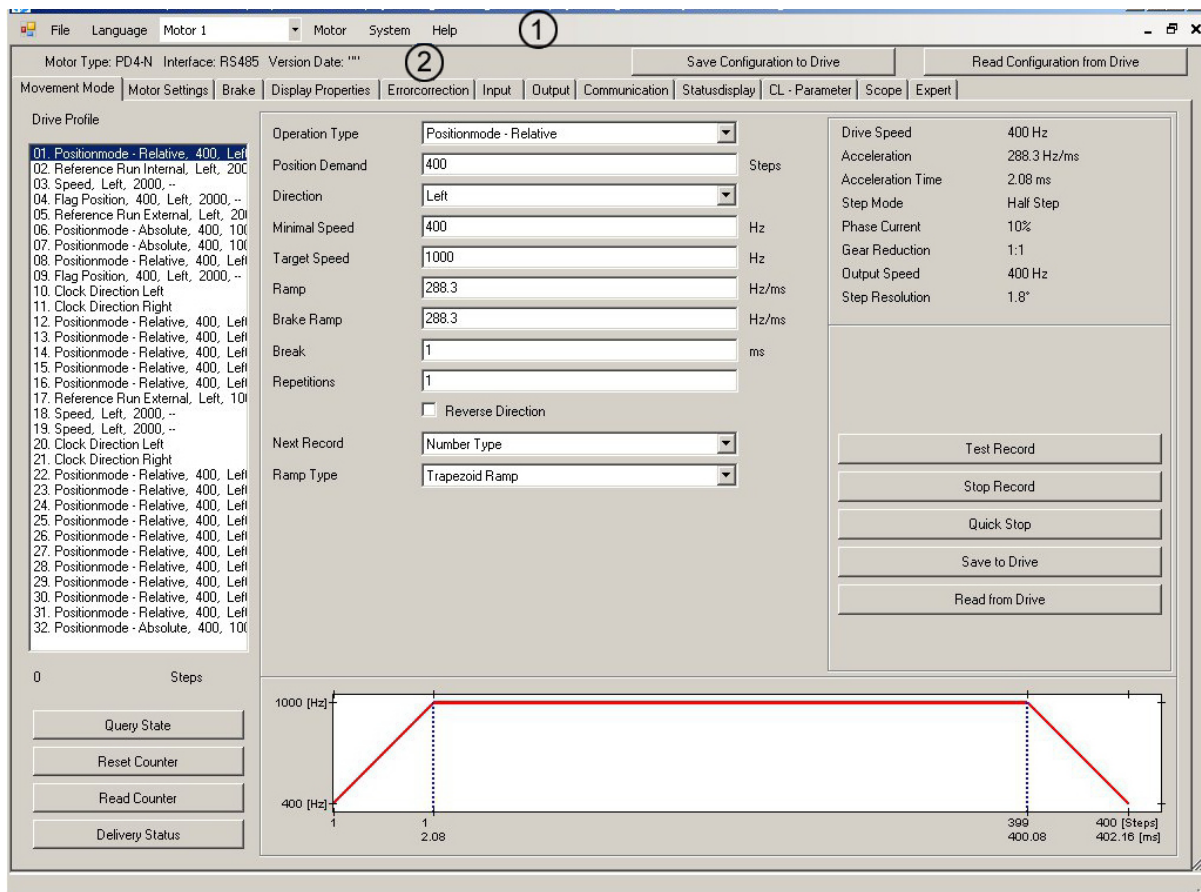

The screenshot displays the NanoPro software interface. At the top, a menu bar (1) includes 'File', 'Language', 'Motor 1', 'Motor', 'System', and 'Help'. Below the menu bar is a toolbar with buttons for 'Save Configuration to Drive' and 'Read Configuration from Drive'. A secondary menu bar (2) contains 'Movement Mode', 'Motor Settings', 'Brake', 'Display Properties', 'Errorcorrection', 'Input', 'Output', 'Communication', 'Statusdisplay', 'CL - Parameter', 'Scope', and 'Expert'. The main window is titled 'Drive Profile' and contains a list of 32 motor profiles on the left. The selected profile is '01 Positionmode - Relative, 400, Left'. The main area shows configuration parameters for this profile, including 'Operation Type' (Positionmode - Relative), 'Position Demand' (400), 'Direction' (Left), 'Minimal Speed' (400), 'Target Speed' (1000), 'Ramp' (288.3), 'Brake Ramp' (288.3), 'Break' (1), 'Repetitions' (1), 'Next Record' (Number Type), and 'Ramp Type' (Trapezoid Ramp). On the right, there are additional parameters: 'Drive Speed' (400 Hz), 'Acceleration' (288.3 Hz/ms), 'Acceleration Time' (2.08 ms), 'Step Mode' (Half Step), 'Phase Current' (10%), 'Gear Reduction' (1:1), 'Output Speed' (400 Hz), and 'Step Resolution' (1.8°). Below these parameters are buttons for 'Test Record', 'Stop Record', 'Quick Stop', 'Save to Drive', and 'Read from Drive'. At the bottom, there is a graph showing the speed profile (Hz) over time (ms) and steps. The graph shows a trapezoidal ramp starting at 400 Hz, reaching 1000 Hz at 2.08 ms, and then decelerating back to 400 Hz at 402.16 ms. The x-axis is labeled 'Steps' and 'ms', with values 1, 2.08, 399, 400.08, and 402.16. The y-axis is labeled 'Hz' with values 400 and 1000.

2.2.1 The menu bar

<File> menu

Standard functions for file editing.

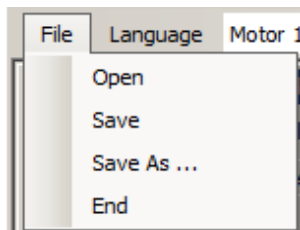

<Language> menu

The operating interface language can be changed here (German/English).

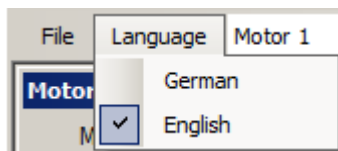

"Motor" selection menu

Selection of the required motor.

In networks, up to 254 motors can be operated on a linked basis and actuated by the NanoPro control software.

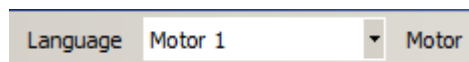

<Motor> menu

The <Motor> menu has the following menu items:

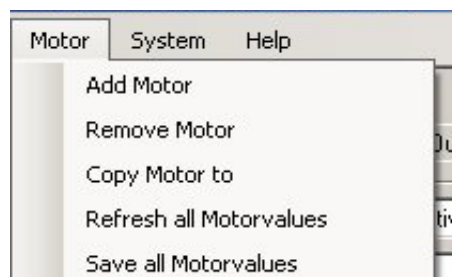

- <Add Motor>
New motors can be added via the <Add Motor> menu item.
An input window for the motor address opens. The address must be between 1 and 254.
- <Remove Motor>
Motors that are no longer required can be removed from the controller in the <Remove Motor> menu item.
This opens a window with the query "Do you really want to delete this motor?", which you can quit with the <Yes> button.
- <Copy Motor to>
You can copy and adopt the current settings for a new motor with this menu item.
An input window for the motor address opens. The address must be between 1 and 254.
- <Refresh all Motorvalues>
All motor settings are transferred to the NanoPro control software.

- <Save all Motorvalues>
All motor settings are saved in the controller.

<System> menu

The <System> menu has the following menu items:

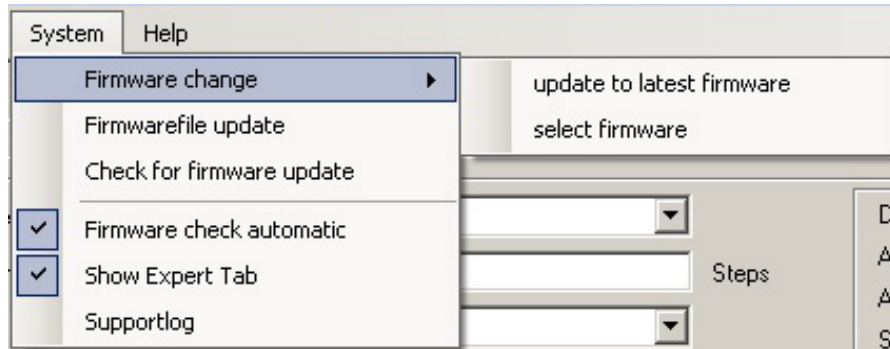

- <Firmware change>
 - <update to latest firmware>: Update the firmware in the controller to the latest firmware located in the firmware file for that controller.
 - <select firmware>: Select the firmware.
- <Firmwarefile update>
Update of the firmware file (in the NanoPro installation directory) to a new firmware file from the Nanotec webserver.
- <Check for firmware update>
Manually check whether an update for the firmware is available.
- <Firmware check automatic>
When the checkbox is activated, an automatic check is made of whether a firmware update is available.
- <Show Expert Tab>
When the checkbox is activated, the <Expert> tab is displayed in the tab bar.
- <Supportlog>
When the checkbox is activated, a log file is automatically created for support purposes.

<Help> menu

The <Help> menu has the following menu items:

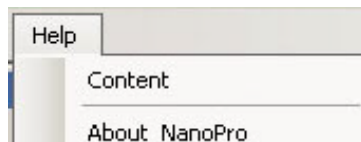

- <Content>
Call up the online help for NanoPro.
- <About NanoPro>
Display the version information for the latest installation of NanoPro.

2.2.2 The menu window

Tabs

The menu window contains the following tabs:

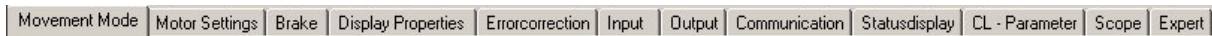

Tab	See Section
State	4 „<Mode> tab“
Motor Settings	5 „<Motor settings> tab“
Brake	6 „<Brake> tab“
Display Properties	7 „<Display Settings> tab“
Error correction	8 „<Errorcorrection> tab“
Inputs	9 „<Inputs> tab“
Outputs	10 „<Outputs> tab“
Communication	11 „<Communication> tab“
Statusdisplay	12 „<Status display> tab“
CL Parameter	13 „<CL-Parameter> tab (closed loop)“
Scope	14 „<Scope> tab“
Expert (display must be activated via <System → Show Expert Tab>).	15 „<Expert> tab“

Transferring settings to/from controller

The current configuration settings can be saved in the connected controller or read from the connected controller using the following buttons.



- <Save Configuration to Drive>
The current settings are transferred from the NanoPro to the connected controller.
- <Read Configuration from Drive>
The current settings are transferred from the connected controller to NanoPro.

3 Configuring the controller

General information

This section describes the general procedure for configuring the controller. The parameters to be configured on the respective tabs are described in detail in Sections 4 to 15.

Procedure

To configure the drivers, proceed as follows:

Step	Action	Note
1	Commission the controller and establish communication with the controller.	See technical manual of the respective controller.
2	Click on the <Read Configuration from Drive> button. The connected controller type is detected and displayed in the <Motor settings> tab. The parameters applicable for the respective controller type are displayed.	See Section 5 “<Motor settings> tab”
3	If this is not a Plug & Drive motor: Select the motor type and motor designation (see motor type plate) in the <Motor settings> tab. Motor type and designation are detected automatically for Plug & Drive motors.	See Section 5 “<Motor settings> tab”
4	Enter the required parameters in the tabs and click, if necessary, on the <Save Data> button to transfer the settings of the respective tab to the motor controller.	<ul style="list-style-type: none">• See Section 4.2 „Entering the profile parameters“, for example.
5	Click on the <Save Configuration to Drive> button, if necessary, to transfer all settings from NanoPro to the controller.	<ul style="list-style-type: none">•

4 <Mode> tab

4.1 Overview

Introduction

Depending on the travel profile, the motor can be operated using 14 different operating modes, see also Section 4.2 "Entering the profile parameters". Due to the great capacity and functions available, it offers designers and developers a rapid and simple method of resolving numerous drive requirements with less programming effort.

Select the required operating mode for each drive profile and configure the controller according to your requirements.

Overview of operating modes and their areas of application

Operation mode	Application
Positionmode - Relative	Use this mode when you wish to travel to a specific position. The motor travels according to a specified drive profile from a Position A to a Position B. Please refer to Section 4.3 "Relative and absolute positioning, internal and external reference run".
Positionmode - Absolute	
Internal reference run	During the internal reference run, the motor travels to an internal reference point at the set minimum speed. Please refer to Section 4.3 "Relative and absolute positioning, internal and external reference run".
External reference run	During an external reference run, the motor travels to a switch connected to the reference input. Please refer to Section 4.3 "Relative and absolute positioning, internal and external reference run".
Speed mode	Use this mode when you wish to travel with a specific speed (e.g. a conveyor belt or pump speed). In the speed mode, the motor accelerates with a specified ramp from the starting speed (start frequency "V Start") to the specified maximum speed (maximum frequency "V Normal"). Several inputs enable the speed to be changed on-the-fly to different speeds. Please refer to Section 4.4 "Speed Mode".
Flag positioning mode	The flag positioning mode offers a combination of the speed and positioning modes. The motor is initially operated in speed mode; when a trigger point is reached, it changes to the positioning mode and the specified setpoint position (relative to the trigger position) is approached. This operating mode is used for labeling, for example: the motor first travels with the set ramp to the synchronous speed of the conveyed goods. When the labels are detected, the preset distance (position) is traveled to apply the labels. Please refer to Section 4.5 "Flag Positioning Mode".

Operation mode	Application
Clock direction mode, left	<p>Use this mode when you wish to operate the motor with a superordinate controller (e.g. CNC controller). In the clock-direction mode, the motor is operated via two inputs with a clock and a direction signal from a superordinate positioning control (indexer). Depending on the mode selected (Int. Ref./Ext. Ref.), the internal and external reference runs are supported. Please refer to Section 4.6 "Clock-Direction Mode Int. Ref./Ext. Ref."</p>
Clock direction mode, right	
Clock direction mode Int. Ref.	
Clock direction mode Ext. Ref.	
Analog and joystick mode	<p>The motor is controlled in this operating mode simply with a potentiometer or a joystick (−10 V to +10 V). Use this mode if you want to use the motor in a simple application:</p> <ul style="list-style-type: none"> • Setting a specific speed, e.g. via an external potentiometer, • Traveling synchronously with a superordinate controller with analog output (−10 V to +10 V). <p>Please refer to Section 4.7 "Analog and Joystick Mode".</p>
Analogue positioning mode	<p>Use this mode when you wish to travel to a specific position. The voltage level at the analog input is proportionate to the desired position, thus enabling servo performance. Please refer to Section 4.8 "Analogue Positioning Mode".</p>
Torque mode	<p>Use this mode when you require a specific output torque independent of the speed as is the case in typical winding and unwinding applications. The maximum torque is specified via the analog input. Please refer to Section. 4.9 „Torque mode“</p>

4.2 Entering the profile parameters

Introduction

Up to 32 travel profiles can be defined and programmed.

You can assign important profile parameters to a travel profile using the NanoPro software.

The parameters listed below do not all have to be specified for all travel modes. When the operation mode is activated or changed, the relevant fields are displayed in the <Movement Mode> tab.

<Movement Mode> tab

The profile parameters for a specific travel profile are set on the <Movement Mode> tab.

The screenshot shows the NanoPro software interface with the <Movement Mode> tab selected. The interface is divided into several sections:

- Top Menu:** Movement Mode | Motor Settings | Brake | Display Properties | Errorcorrection | Input | Output | Communication | Statusdisplay | CL - Parameter | Scope | Expert
- Left Panel (Drive Profile List):** A list of 32 profiles. Profile 01 is selected: "01. Positionmode - Relative, 400, Left".
- Central Configuration Area:**
 - Operation Type: Positionmode - Relative
 - Position Demand: 400
 - Direction: Left
 - Minimal Speed: 400
 - Target Speed: 1000
 - Ramp: 288.3
 - Brake Ramp: 288.3
 - Break: 1
 - Repetitions: 1
 - Next Record: Number Type
 - Ramp Type: Trapezoid Ramp
 - Reverse Direction:
- Right Panel (Drive Parameters):**
 - Drive Speed: 400 Hz
 - Acceleration: 288.3 Hz/ms
 - Acceleration Time: 2.08 ms
 - Step Mode: Half Step
 - Phase Current: 10%
 - Gear Reduction: 1:1
 - Output Speed: 400 Hz
 - Step Resolution: 1.8°
- Bottom Panel (Graph):** A speed profile graph showing frequency [Hz] vs. time [ms]. The speed starts at 400 Hz, ramps up to 1000 Hz at 2.08 ms, remains constant at 1000 Hz until 400.08 ms, and then ramps down to 400 Hz at 402.16 ms.
- Bottom Left Panel:** Buttons for Query State, Reset Counter, Read Counter, and Delivery Status.
- Bottom Right Panel:** Buttons for Test Record, Stop Record, Quick Stop, Save to Drive, and Read from Drive.

Drive Profile selection list

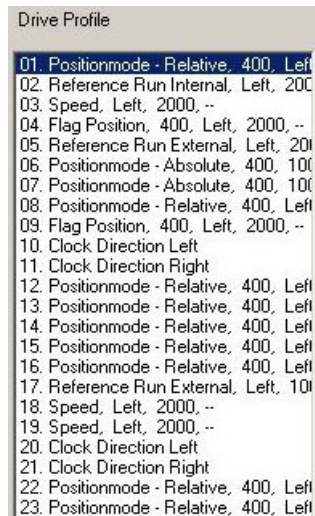

- This window displays the maximum possible 32 travel profiles.
- After selecting the required travel profile, the corresponding profile parameters are displayed in the parameter area.

“Operation Type” selection menu

- The required operating type can be selected here.

Profile parameters

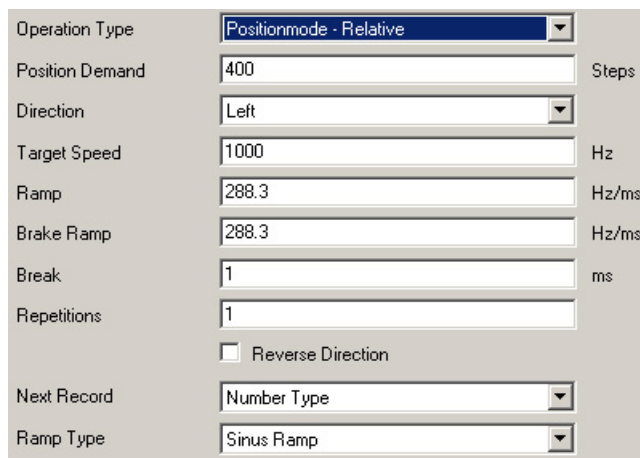

- Displays parameters dependent on the selected operating type and travel profile.
- Settings of required parameters for the various profiles (max. 32).

Motor parameters

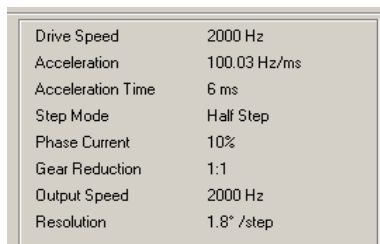

- Display of the parameters of the connected motor.
- Setting of parameters, see Section 5 "<Motor settings> tab".

Buttons for communication with the controller

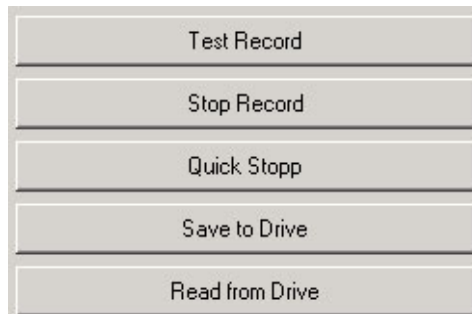

- <Test Record>
Activation of the <Test Record> button transmits the current record to the controller and starts it. The parameters are not stored by the controller.
- <Stop Record>
The currently operating record is stopped.
- <Quick Stop>
The currently operating record is stopped – independent of the travel profile – with the Quick Stop ramp. For the settings, see Section 5 "<Motor settings> tab".
- <Save Data>
Pressing the <Save Data> button permanently stores the set travel profile in the controller.
Transfer can take a few seconds and is visually displayed with a progress bar.
The travel profiles can then be selected and started via the motor inputs.
- <Read from Drive>
All record data stored in the controller is loaded onto your PC.

Display profile graph

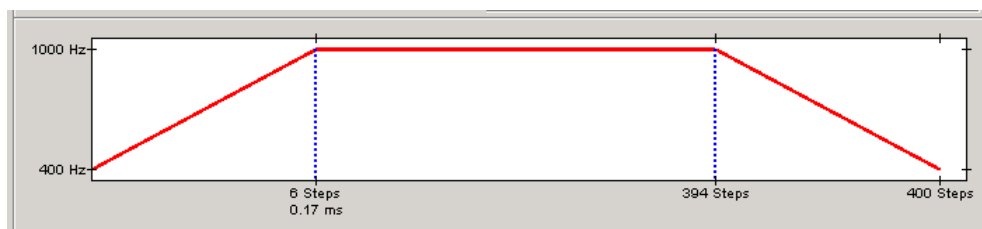

- The displayed profile graph can be used to rapidly see the ramp times (acceleration time) and the overall actuating time for the applicable travel profile.
- The graphic is recalculated after every relevant input.

Buttons for motor position/communication with the optional encoder

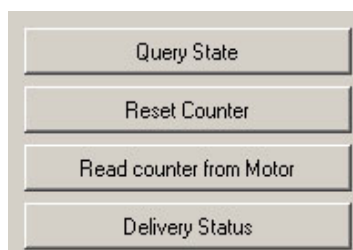

- <Query State>
Pressing the <Query State> button queries the actual state of the motor and displays the state on the screen.
- <Reset counter>
Pressing the <Reset counter> button resets the current counter value to zero.

- <Read Counter>
Pressing the <Read Counter> button queries the actual counter value and displays it on the screen.
- <Delivery Status>
Pressing the <Delivery Status> button resets all parameter settings of the motor to the delivered state.

Procedure

The following describes an example of how to enter profile parameters for a travel profile in the "Relative" operation type. Other parameters must be defined in other operating modes.

Proceed as follows:

Step	Action	Note
1	Select the required travel profile in the <Movement Mode> tab, e.g. "01. Relative, 400,-".	The parameter values of the selected travel profile are displayed. The travel profile is defined by the positioning mode ("Operation Type" selection menu) and the distances in the "Position Demand" field.
2	In the "Operation Type" selection menu, select the "Relative" mode.	The relevant parameter fields are displayed.
3	Enter the desired parameters.	See Section 4.3.3 "Profile parameters".
4	If you want to test the entered travel profile: Click on the <Test Record> button.	The motor then travels according to the selected operating mode and travel profile.
5	Repeat steps 1 to 4 if you want to enter further travel profiles.	
6	If you want to permanently save the entered settings: Click on the <Save Data> button.	The data are then saved in the controller.

4.3 Relative and absolute positioning, internal and external reference run

4.3.1 Description

Function

Relative and absolute positioning

In the "Relative" and "Absolute" operation types, the motor moves from a position A to a position B according to a specified travel profile.

They are preferentially used when travel to a specific position is required.

The positions can be defined as absolute or relative values depending on the mode selected. With relative positioning the travel profile is started from the actual position. With absolute positioning, the travel profile starts from a specified zero position, irrespective of the actual position.

Internal and external reference run

In the "Internal reference run" operation type, the motor travels to an internal reference point at the set minimum speed (index mark of encoder).

In the "External reference run" operation type the motor travels to a switch connected to the reference input.

After the start of the external reference run, the motor accelerates with the set ramp from the minimum to the maximum speed. Once the reference switch is reached, movement is stopped for a break of 100 ms and then, according to the "Limit switch behavior internal/external" setting (see Section 9 "<Inputs> tab", "Behavior for Internal / External Homing"), travel is recommenced away from the switch at the minimum speed (start/stop speed).

The reference switch can be an opener or a closer. This must be set with the software during programming.

See also Section 9 "<Inputs> tab" and the separate manual for the respective stepper motor controller or for the Plug & Drive motor.

Parameter fields for the "Relative" operation type

Operation Type	Positionmode - Relative	
Position Demand	400	Steps
Direction	Left	
Minimal Speed	400	Hz
Target Speed	1000	Hz
Ramp	288.3	Hz/ms
Brake Ramp	288.3	Hz/ms
Break	1	ms
Repetitions	1	
	<input type="checkbox"/> Reverse Direction	
Next Record	Number Type	
Ramp Type	Sinus Ramp	

Parameter fields with the "Absolute" operation type

Operation Type	<input type="text" value="Positionmode - Absolute"/>	
Position Demand	<input type="text" value="400"/>	Steps
Target Speed	<input type="text" value="1000"/>	Hz
Ramp	<input type="text" value="288.3"/>	Hz/ms
Brake Ramp	<input type="text" value="288.3"/>	Hz/ms
Next Record	<input type="text" value="Number Type"/>	
Ramp Type	<input type="text" value="Sinus Ramp"/>	

Parameter fields with the "Reference Run Internal" operation type

Operation Type	<input type="text" value="Reference Run Internal"/>	
Direction	<input type="text" value="Left"/>	
Target Speed	<input type="text" value="1000"/>	Hz
Ramp	<input type="text" value="288.3"/>	Hz/ms
Brake Ramp	<input type="text" value="288.3"/>	Hz/ms
Break	<input type="text" value="1"/>	ms
Repetitions	<input type="text" value="1"/>	
Next Record	<input type="text" value="Number Type"/>	
Ramp Type	<input type="text" value="Sinus Ramp"/>	

Parameter fields with the "Reference Run External" operation type

Operation Type	<input type="text" value="Reference Run External"/>	
Direction	<input type="text" value="Left"/>	
Target Speed	<input type="text" value="1000"/>	Hz
Ramp	<input type="text" value="288.3"/>	Hz/ms
Brake Ramp	<input type="text" value="288.3"/>	Hz/ms
Break	<input type="text" value="1"/>	ms
Repetitions	<input type="text" value="1"/>	
Next Record	<input type="text" value="Number Type"/>	
Ramp Type	<input type="text" value="Sinus Ramp"/>	

4.3.2 Assignment of the inputs and outputs

General information

The inputs and outputs are freely configurable; see Section 9 "<Inputs> tab" and Section 10 "<Outputs> tab".

Possible input configuration

The inputs can be configured with the following functions:

- Start/reset
- Record bit 0 to record bit 4
- External reference switch

4.3.3 Profile parameters

Parameter descriptions

The following parameters can be set:

Parameters	Function
Position Demand	<ul style="list-style-type: none"> • Absolute or relative position for the selected travel profile (distance). • The control variable can be input in steps, degrees or mm. • The units of measurement can be changed in the <Display Properties> tab.
Direction (not with absolute positioning)	Direction of rotation of travel profile <ul style="list-style-type: none"> • Left • Right
Minimal Speed	"Start speed" (V Start): <ul style="list-style-type: none"> • Start speed (start/stop frequency) of the motor in Hz. • To avoid step losses, it should be selected to be above the natural resonance of the motor. • Too high a minimum speed can also lead to step losses. • The units of measurement can be changed in the <Display Properties> tab.
Target Speed	"Normal speed" (V Normal): <ul style="list-style-type: none"> • Normal travel speed of the motor in Hz. • To avoid step losses, it should lie outside the resonance ranges. • Too high a maximum speed can cause step losses and motor stalling. • The units of measurement can be changed in the <Display Properties> tab.
Ramp / Brake Ramp	Ramp gradient: <ul style="list-style-type: none"> • Values are entered in Hz/ms. • The steeper the ramp, the faster the acceleration; however, if the acceleration is too high, the motor can skip and lose steps. • Any possible resonance ranges must be traversed as fast as possible. • The maximum value is 3000 Hz/ms. The set value is output as the next possible speed due to the coding in the motor (at 3000 Hz/ms e.g. as 2988.3 Hz/ms). • The minimum value is 0.1 Hz/ms. • Brake ramp: The value 0 means that the value set in the "Ramp" field for the acceleration ramp is also applied for the brake ramp.
Break (only with relative positioning)	<ul style="list-style-type: none"> • The idle time of the motor (in ms) when several runs must be implemented in sequence. • The minimum duration of the adjustable break is 1 ms.

Parameters	Function
Repetitions (only with relative positioning)	The "Repetitions" parameter indicates how often the selected travel profile should be implemented automatically in sequence without another start command. A value of 0 means that the selected travel profile is traveled an infinite number of consecutive times.
Reverse direction (only with relative positioning)	<ul style="list-style-type: none">• An automatic change of direction can be activated in the "Reverse Direction" option field.• In active change of direction, the rotation direction of the motor is automatically changed when the same record is called up repeatedly in sequence.
Next Record	A travel profile can be defined in this selection menu to be started when the current record is ended.

Parameters	Function						
Ramp Type	<p>The following ramp types can be selected:</p> <ul style="list-style-type: none"> • Trapezoid ramp • Sinus ramp • Jerk Free Ramp <p>The following additional parameter fields appear if the "Jerk Free Ramp" has been selected:</p> <table border="1" data-bbox="644 551 1342 703"> <tr> <td>Jerk</td> <td><input type="text" value="721"/></td> </tr> <tr> <td>Brake Ramp</td> <td><input type="text" value="721"/></td> </tr> <tr> <td>Brake Jerk</td> <td><input type="text" value="721"/></td> </tr> </table> <p>Possible values: 1 to 65,536</p> <p>The "Max. Acceleration Jerk" and "Max. Brake Jerk" parameters indicate the maximum change of acceleration over time. The greater the jerk, the faster the acceleration can change. A very small jerk leads to a sinusoidal acceleration ramp while a large jerk leads to a trapezoidal ramp, see following figure:</p> <div data-bbox="651 936 1278 1294"> <p>Speed</p> <p>Minor jolt</p> <p>Max. acceleration reached</p> <p>Time</p> </div> <div data-bbox="660 1352 1158 1720"> <p>Speed</p> <p>Major jolt</p> <p>Max. acceleration reached</p> <p>Time</p> </div>	Jerk	<input type="text" value="721"/>	Brake Ramp	<input type="text" value="721"/>	Brake Jerk	<input type="text" value="721"/>
Jerk	<input type="text" value="721"/>						
Brake Ramp	<input type="text" value="721"/>						
Brake Jerk	<input type="text" value="721"/>						

Profile graph display

The displayed profile graph shows the ramp times (acceleration time) and the overall actuating time for the applicable travel profile.

The graphic is recalculated after every relevant input. This allows you to continually check and, where necessary, correct the settings made.

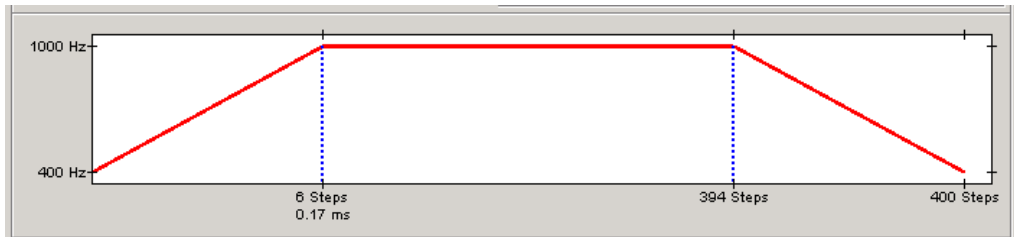

4.3.4 Signal curves

Example of a signal curve

In this example, travel profile 5, then travel profile 3, followed by travel profile 16 (programmed as reference run) are started.

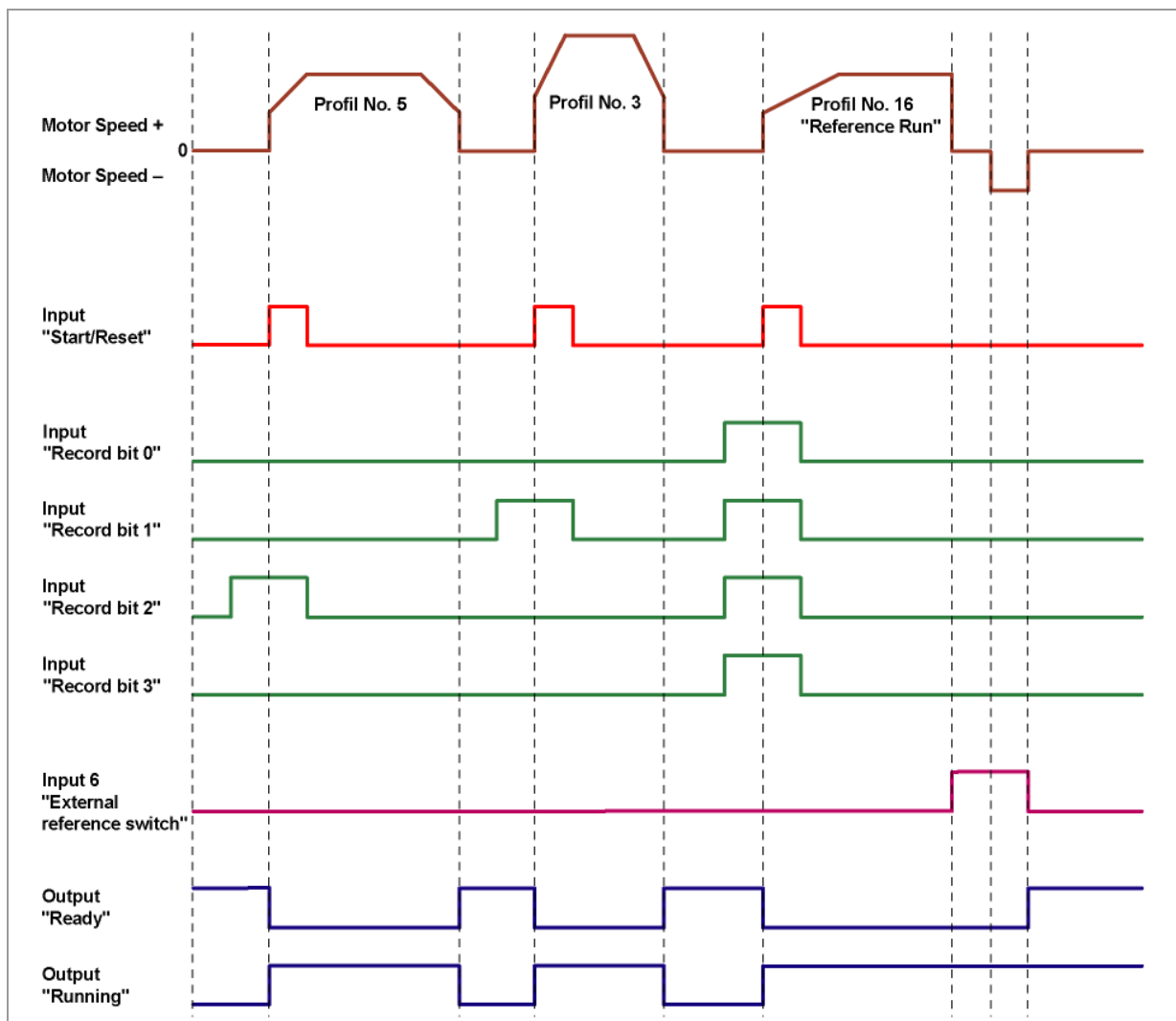

4.4 Speed Mode

4.4.1 Description

Function

In the speed mode, the motor accelerates with a specified ramp from the starting speed (minimal speed/start frequency) to the specified maximum speed (target speed/maximum frequency).

The speed mode is generally used when a specific travel speed is required (e.g. for a conveyor belt or a pump).

Parameter fields for “Speed” operation type

Operation Type	Speed	
Direction	Left	
Minimal Speed	400	Hz
Target Speed	1000	Hz
Ramp	10	Hz/ms
Brake Ramp	0	Hz/ms
Ramp Type	Trapezoid Ramp	

Speed changes

Speed changes can be implemented at any time via the inputs or the interface. Unlike the other operation modes, the state of the inputs is read in during travel and the associated speed parameters are output. When the speed changes, the motor accelerates or brakes with the set ramp to the new setpoint speed.

If you start the motor for test purposes via the NanoPro control software (click on <Test Record> button), the following buttons change:

Test Record
Stop Record
Quick Stopp
increase frequency
decrease frequency

- The <Save to Drive> button changes to the <increase frequency> button: Clicking on the button increases the frequency (speed) of the motor by 100 Hz. The current frequency value is shown in the window at the top right ("Drive Speed").
- The <Read from Drive> button changes to the <decrease frequency> button: Clicking on the button decreases the frequency (speed) of the motor by 100 Hz. The current frequency value is shown in the window at the top right ("Drive Speed").

4.4.2 Assignment of the inputs and outputs

General information

The inputs and outputs are freely configurable; see Section 9 "<Inputs> tab" and Section 10 "<Outputs> tab".

Possible input configuration

The inputs can be configured with the following functions:

- Start/reset
- Record bit 0 to record bit 4
- Direction (direction of rotation of motor)

4.4.3 Profile parameters

Parameter descriptions

The following parameters can be set in the speed mode:

Parameters	Function
Direction	Direction of rotation of travel profile: <ul style="list-style-type: none"> • Left • Right The direction of rotation of the motor is only relevant when the motor is operated via the programming interface. Otherwise, the direction of rotation is selected via an input.
Minimal Speed	"Starting speed" <ul style="list-style-type: none"> • The minimum speed in Hz is the startup speed (start-stop frequency) of the motor. • To avoid step losses, it should be selected to be above the natural resonance of the motor. • Too high a minimum speed can also lead to step losses.
Target Speed	"Normal speed": <ul style="list-style-type: none"> • The maximum speed in Hz is the setpoint speed of the motor. • To avoid rough operation, it should lie outside resonance ranges. • Too high a maximum speed can cause step losses and motor stalling.
Ramp / Brake Ramp	Input of ramp gradient in Hz/ms. Brake ramp: The value 0 means that the value set in the "Ramp" field for the acceleration ramp is also applied for the brake ramp.
Ramp Type	The following ramp types can be selected: <ul style="list-style-type: none"> • Trapezoid ramp • Sinus ramp • Jerk Free Ramp (see Section 4.3.3)

Profile graph display

The displayed profile graph shows the ramp times (acceleration time) and the setpoint speed for the applicable travel profile.

The graphic is recalculated after every relevant input. This allows you to continually check and, where necessary, correct the settings made.

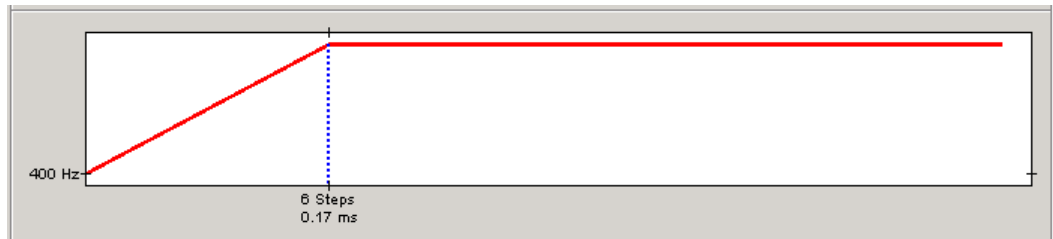

4.4.4 Signal curves in the Speed Mode

Example of a signal curve

In the example, speeds of travel profile 4, travel profile 7 and, after a change of direction, the speed of travel profile 13 are used.

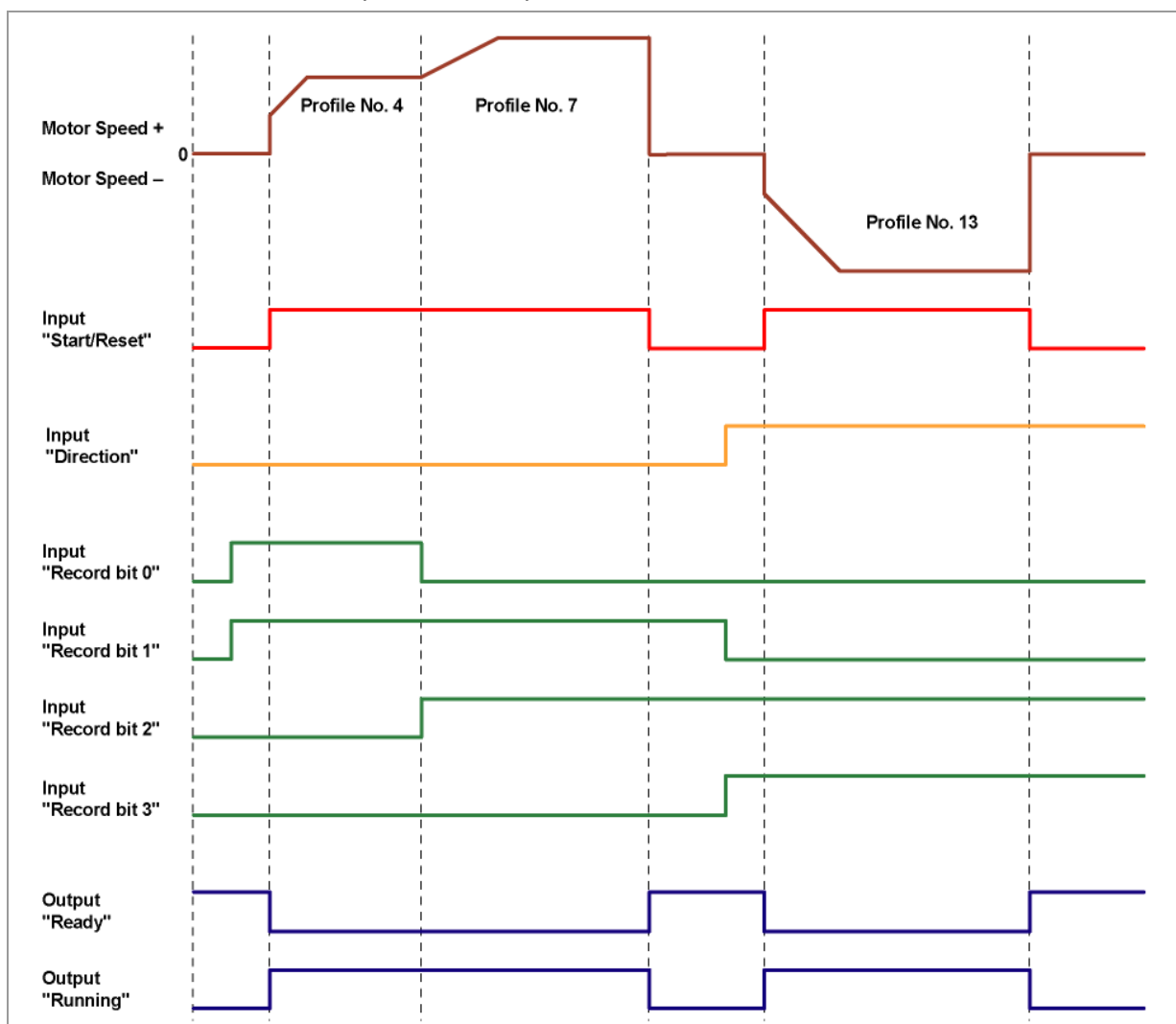

4.5 Flag Positioning Mode

4.5.1 Description

Function

The flag positioning mode offers a combination of the speed and positioning modes. The motor is first operated in speed mode to travel an undefined distance with a specific speed, for example. When a trigger (trigger point) is reached, e.g. a limit switch, operation is switched to the relative positioning mode to travel to a defined setpoint position (relative to the trigger position).

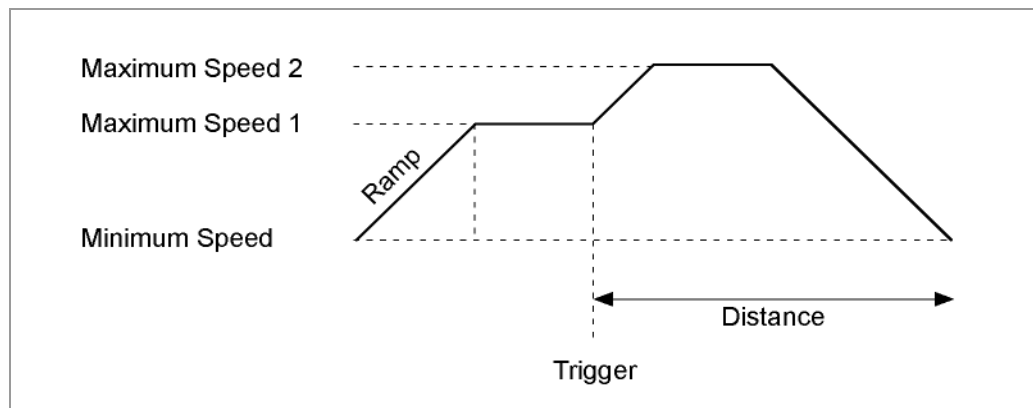

Parameter fields in the “Flag Position” operation type

Operation Type	<input type="text" value="Flag Position"/>	
Position Demand	<input type="text" value="400"/>	Steps
Direction	<input type="text" value="Left"/>	
Target Speed	<input type="text" value="1000"/>	Hz
V Maximum	<input type="text" value="25000"/>	Hz
Ramp	<input type="text" value="288.3"/>	Hz/ms
Brake Ramp	<input type="text" value="288.3"/>	Hz/ms
Break	<input type="text" value="1"/>	ms
Repetitions	<input type="text" value="1"/>	
Next Record	<input type="text" value="Number Type"/>	
Ramp Type	<input type="text" value="Sinus Ramp"/>	

Manually setting the trigger signal

The trigger signal can be set manually at input 5 via the NanoPro control software.

If you start the motor for test purposes (click on the <Test Record> button), the following button changes:



- The <Test Record> button changes to the <Trigger on> button: When this button is clicked, the trigger signal is set and the motor changes from the Speed mode to the Relative positioning mode.

4.5.2 Assignment of the inputs and outputs

General information

The inputs and outputs are freely configurable; see Section 9 "<Inputs> tab" and Section 10 "<Outputs> tab".

Possible input configuration

The inputs can be configured with the following functions:

- Start/reset (starts the speed mode)
- Record bit 0 to record bit 4
- Trigger (starts the positioning mode)
- External reference switch

4.5.3 Profile parameters

Parameter descriptions

The following parameters can be set in the flag positioning mode:

Parameters	Function
Position Demand	<ul style="list-style-type: none"> • Distance for the selected travel profile. • The number of motor steps to be output can be selected up to 16,777,215 steps.
Direction	Direction of rotation of travel profile: <ul style="list-style-type: none"> • Left • Right

Parameters	Function
Minimal Speed	<p>"Starting speed"</p> <ul style="list-style-type: none"> The minimum speed in Hz is the startup speed (start-stop frequency) of the motor. To avoid step losses, it should be selected to be above the natural resonance of the motor. Too high a minimum speed can also lead to step losses.
Target Speed	<p>"Maximum speed 1":</p> <ul style="list-style-type: none"> The maximum speed <u>before</u> the trigger pulse (speed mode) in Hz. To avoid step losses, it should be selected to be above the natural resonance of the motor. Too high a maximum speed can cause step losses and motor stalling.
V Maximum	<p>"Maximum speed 2":</p> <ul style="list-style-type: none"> The maximum speed <u>after</u> the trigger pulse (positioning mode) in Hz. Default set to 1000 Hz. To avoid step losses, it should be selected to be above the natural resonance of the motor. Too high a maximum speed can cause step losses and motor stalling.
Ramp / Brake Ramp	<p>Input of ramp gradient in Hz/ms. Brake ramp: The value 0 means that the value set in the "Ramp" field for the acceleration ramp is also applied for the brake ramp.</p>
Break	<ul style="list-style-type: none"> The idle time of the motor (in ms) when several runs must be implemented in sequence. The minimum duration of the adjustable break is 1 ms.
Repetitions	<p>The "Repetitions" parameter indicates how often the selected travel profile should be implemented automatically in sequence without another start command.</p>
Next Record	<p>A travel profile can be defined in this selection menu to be called up when the current record is ended.</p>
Ramp Type	<p>The following ramp types can be selected:</p> <ul style="list-style-type: none"> Trapezoid ramp Sinus ramp Jerk Free Ramp (see Section 4.3.3)

Profile graph display

The displayed profile graph shows the ramp times (acceleration time) and the overall actuating time for the applicable travel profile.

The graphic is recalculated after every relevant input. This allows you to continually check and, where necessary, correct the settings made.

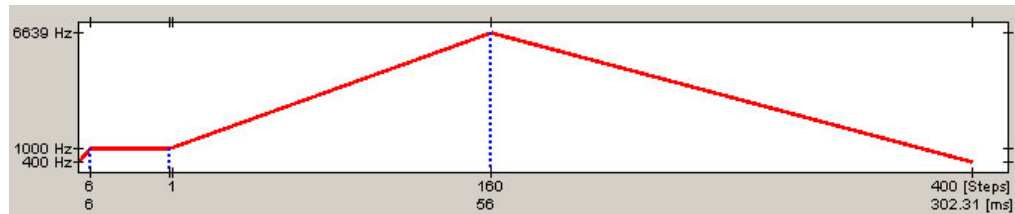

4.5.4 Signal curves in the Flag Positioning Mode

In this example, travel profile 4 is started and then a reference run (programmed as travel profile 8) is started.

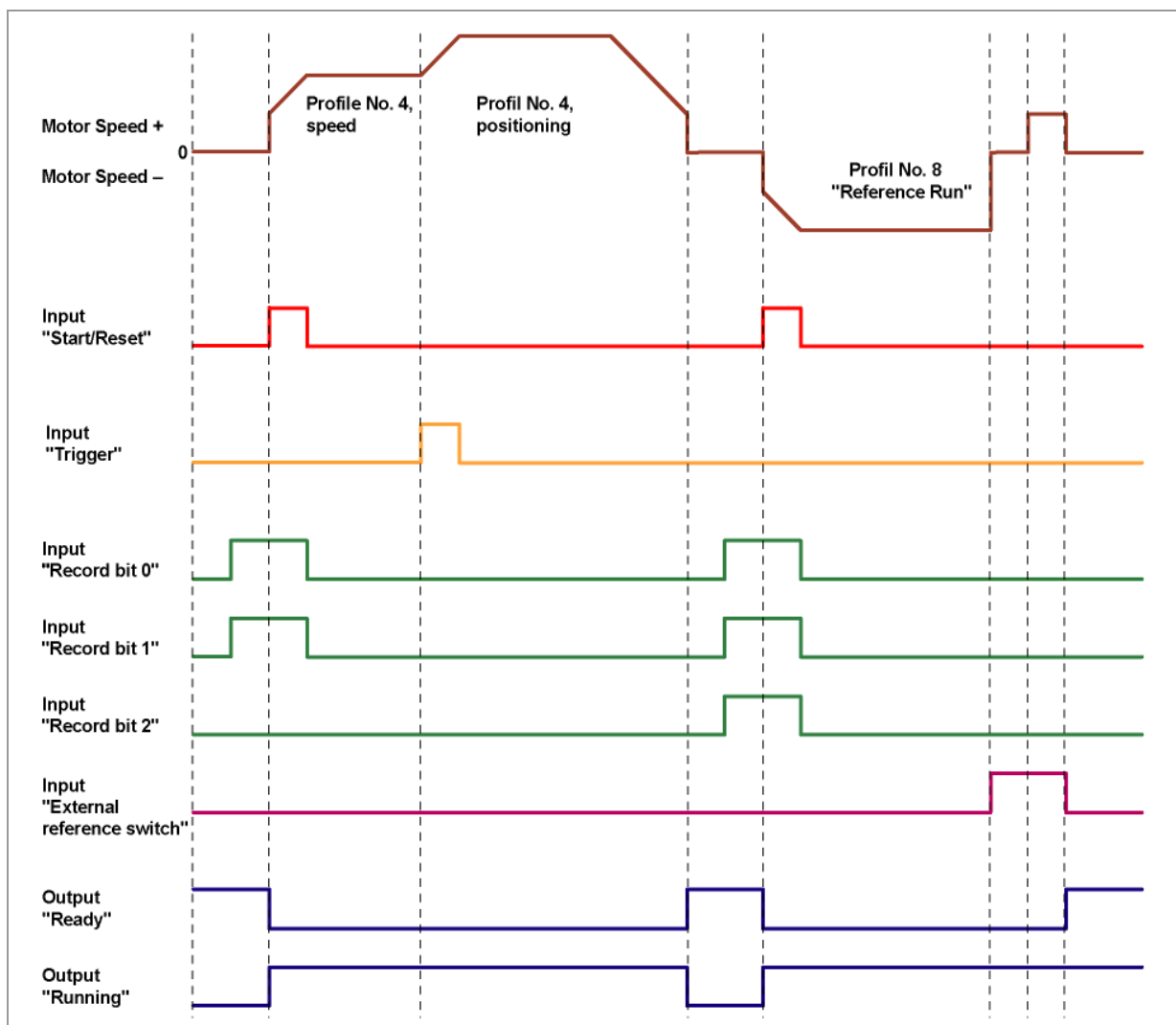

4.6 Clock-Direction Mode Int. Ref./Ext. Ref. / Left/Right

4.6.1 Description

Function

In the Clock-Direction Modes, the motor is operated via two inputs with a clock and a direction signal from a superordinate positioning control (indexer).

With the Clock Direction Left/Right modes, the motor can be moved manually into the selected rotation direction. With every clock signal, the motor moves one step in the direction set by the direction signal. The motor can be started by clicking on the <Test Record> button.

In the Int. Ref./Ext. Ref Clock-Direction Modes, the internal or external reference runs are supported (see Section 9 "<Inputs> tab" and the separate manual for the respective stepper motor controller or for the Plug & Drive motor).

Parameter fields in the "Clock Direction Left/Right" operation type

Operationsmodus	Takt-Richtung links	
Startgeschwindigkeit	0	Hz
Sollgeschwindigkeit	1000	Hz
Rampe	288,3	Hz/ms
Bremsrampe	288,3	Hz/ms
Rampentyp	Trapez Rampe	

Parameter fields in the "Clock Direction Run Int. Ref. / Ext. Ref." operation type

Operationsmodus	Takt-Richtung Int. Ref.	
Richtung	Links	
Startgeschwindigkeit	0	Hz
Sollgeschwindigkeit	1000	Hz
Rampe	288,3	Hz/ms
Bremsrampe	288,3	Hz/ms
Rampentyp	Trapez Rampe	

4.6.2 Assignment of the inputs and outputs

General information

The inputs and outputs are freely configurable; see Section 9 "<Inputs> tab" and Section 10 "<Outputs> tab".

Possible input configuration

The inputs can be configured with the following functions:

- Start/reset
- Clock direction mode, mode selection 1
- Clock direction mode, mode selection 2
- External reference switch

- Direction (direction of rotation of the motor):
A signal change at this input must be completed at least 150 μ s before a clock signal.
- Clock

4.6.3 Profile parameters

Parameter descriptions

The following parameters can be set in the clock direction mode:

Parameters	Function
Direction	Direction of rotation of travel profile: <ul style="list-style-type: none"> • Left • Right
Minimal Speed	"Starting speed" <ul style="list-style-type: none"> • The minimum speed in Hz is the startup speed (start-stop frequency) of the motor. • To avoid step losses, it should be selected to be above the natural resonance of the motor. • Too high a minimum speed can also lead to step losses.
Target Speed (only active if there is no external frequency)	"Normal speed": <ul style="list-style-type: none"> • The maximum speed in Hz is the setpoint speed of the motor. • To avoid step losses, it should be selected to be above the natural resonance of the motor. • Too high a maximum speed can cause step losses and motor stalling.
Ramp / Brake Ramp	Input of ramp gradient in Hz/ms. Brake ramp: The value 0 means that the value set in the "Ramp" field for the acceleration ramp is also applied for the brake ramp.

Note:

For controllers with a dspDrive, when using the clock direction mode in 1/32 or 1/64 step mode, the scaling factors P and I should be set to 0 in the PI parameters of the dspDrive since resonances may otherwise occur at high speeds.

4.6.4 Signal curves in the Clock-Direction Mode

In this example, the left and right modes are started after one another and then the external reference run is carried out.

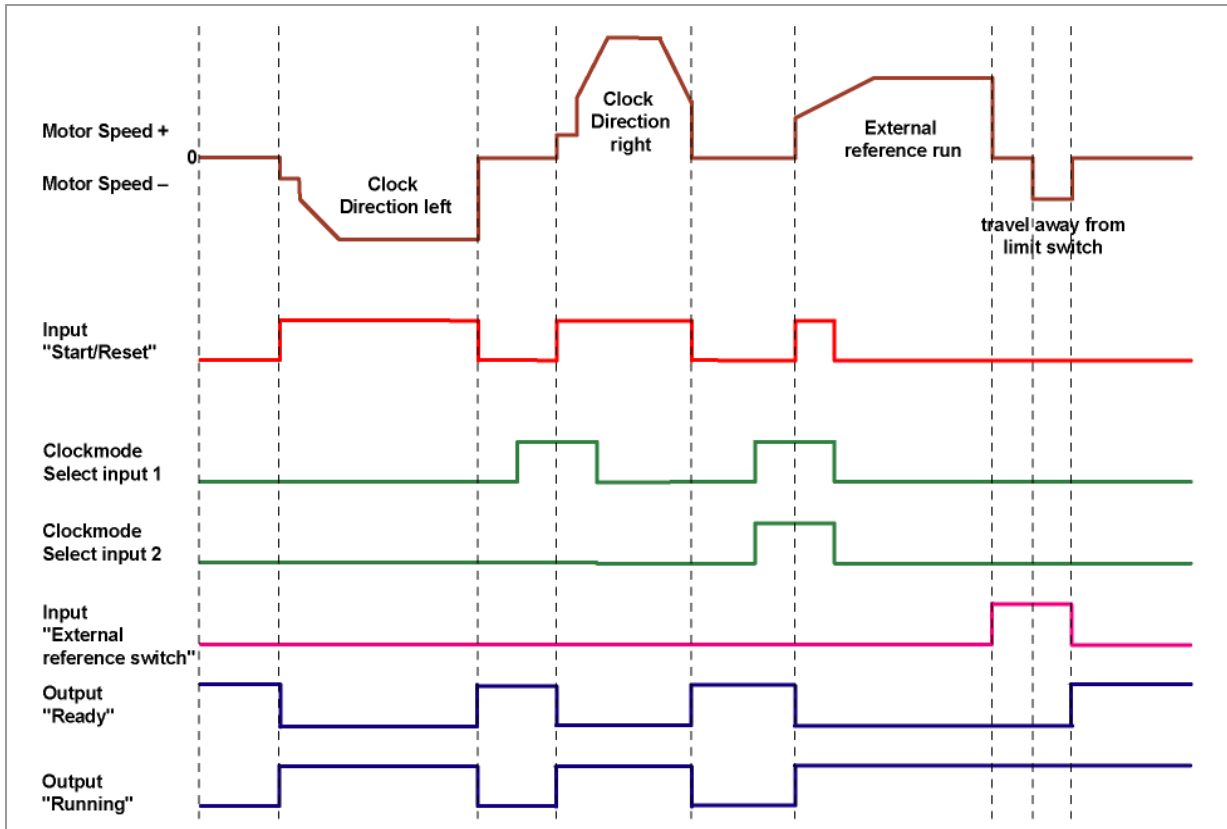

4.7 Analog and Joystick Mode

Note: The analog and joystick modes differ only in a few details. Both modes are therefore described here in one Section.

4.7.1 Description

Function

In the analog or joystick mode, a stepper motor is operated in a simple application:

- with a specific speed, e.g. via an external potentiometer,
- or synchronously with a superordinate controller with analog output (–10 V to +10 V).

The motor is simply actuated either by a potentiometer or an external power supply and a joystick (maximum –10 V to +10 V).

The motor operates at a speed proportional to the applied voltage. The voltage is resolved with an accuracy of 10 bits. The smaller the selected voltage range is, the worse the resolution of the speed will be. To define the voltage range, see Section 9 "<Inputs> tab".

Parameter fields in the “Analog” operation mode

Operationsmodus	Analog	
Richtung	Links	
Startgeschwindigkeit	0	Hz
Sollgeschwindigkeit	1000	Hz
Rampe	288,3	Hz/ms
Bremsrampe	288,3	Hz/ms
Rampentyp	Trapez Rampe	

Parameter fields in the “Joystick” operation mode

Operationsmodus	Joystick	
Startgeschwindigkeit	0	Hz
Sollgeschwindigkeit	1000	Hz
Rampe	288,3	Hz/ms
Bremsrampe	288,3	Hz/ms
Rampentyp	Trapez Rampe	

4.7.2 Assignment of the inputs and outputs

General information

The inputs and outputs are freely configurable; see Section 9 "<Inputs> tab" and Section 10 "<Outputs> tab".

Possible input configuration

The inputs (digital) can be configured with the following functions, for example:

- Start/reset
- Record bit 0 to record bit 4
- Direction

4.7.3 Profile parameters

Parameter descriptions

The following parameters can be set in the analog or joystick mode:

Parameters	Function
Direction (only in Analogue mode)	Direction of rotation of travel profile: <ul style="list-style-type: none"> • Left • Right The direction setting is only significant if no input is configured for direction, since this input would in this case have higher priority. <p>Note: In Joystick mode, the voltage sign determines the direction of rotation (– means "rotate left", + means "rotate right").</p>
Minimal Speed	"Starting speed" <ul style="list-style-type: none"> • The minimum speed in Hz is the startup speed (start-stop frequency) of the motor. • To avoid step losses, it should be selected to be above the natural resonance of the motor. • Too high a minimum speed can also lead to step losses.
Target Speed	"Normal speed": <ul style="list-style-type: none"> • The maximum speed in Hz is the setpoint speed of the motor. • To avoid step losses, it should be selected to be above the natural resonance of the motor. • Too high a maximum speed can cause step losses and motor stalling.
Ramp	Input of ramp gradient in Hz/ms. In the analog and joystick modes, the ramp determines the maximum acceleration. If the voltage changes too fast, e.g. by turning the potentiometer too rapidly, this ramp is used to accelerate to the maximum rotational speed.
Brake ramp	Input of ramp gradient in Hz/ms. In the analog and joystick modes, the brake ramp determines the maximum deceleration. If the voltage changes too fast, e.g. by turning the potentiometer too rapidly, this ramp is used to decelerate to a standstill. The value 0 means that the value set for the acceleration ramp can also be used for the brake ramp.

4.8 Analogue Positioning Mode

4.8.1 Description

Function

A specific position can be approached in this mode.

The analog input can be actuated with max. -10 V to $+10\text{ V}$. The voltage at the analog input directly controls the position. To define the voltage range, see Section 9 "<Inputs> tab".

Parameter fields

Operationsmodus	Analog Position	
Stellgröße	400	Schritte
Startgeschwindigkeit	0	Hz
Sollgeschwindigkeit	1000	Hz
Rampe	288,3	Hz/ms
Bremsrampe	288,3	Hz/ms
Rampentyp	Trapez Rampe	

4.8.2 Assignment of the inputs and outputs

General information

The inputs and outputs are freely configurable; see Section 9 "<Inputs> tab" and Section 10 "<Outputs> tab".

Possible input configuration

The inputs (digital) can be configured with the following functions, for example:

- Start/reset
- Record bit 0 to record bit 4

4.8.3 Profile parameters

Parameter descriptions

The following parameters can be set in the analog positioning mode:

Parameters	Function
Position Demand	<ul style="list-style-type: none"> Distance for the selected travel profile. The number of motor steps to be output can be selected up to 16,777,215 steps.
Minimal Speed	<p>"Starting speed"</p> <ul style="list-style-type: none"> The minimum speed in Hz is the startup speed (start-stop frequency) of the motor. To avoid step losses, it should be selected to be above the natural resonance of the motor. Too high a minimum speed can also lead to step losses.
Target Speed	<p>"Normal speed":</p> <ul style="list-style-type: none"> The maximum speed in Hz is the setpoint speed of the motor. To avoid step losses, it should be selected to be above the natural resonance of the motor. Too high a maximum speed can cause step losses and motor stalling.
Ramp	<p>Input of ramp gradient in Hz/ms.</p> <p>In the analog positioning mode, the ramp determines the maximum acceleration.</p> <p>If the voltage changes too fast, e.g. by turning the potentiometer too rapidly, this ramp is used to accelerate to the maximum rotational speed.</p>
Brake ramp	<p>Input of ramp gradient in Hz/ms.</p> <p>In the analog positioning mode, the brake ramp determines the maximum deceleration.</p> <p>If the voltage changes too fast, e.g. by turning the potentiometer too rapidly, this ramp is used to decelerate to a standstill.</p> <p>The value 0 means that the value set for the acceleration ramp can also be used for the brake ramp.</p>

4.9 Torque mode

Display

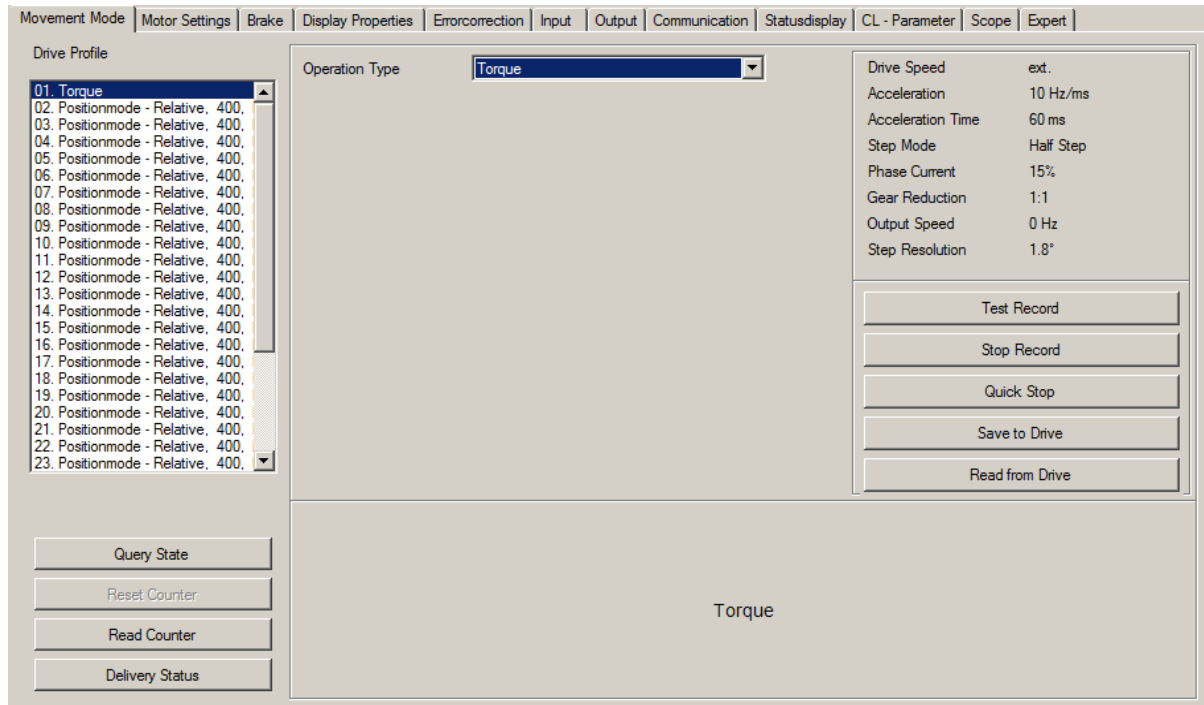

Function

The torque mode is used to rotate the motor at a constant torque.

The torque is determined by the analog input (see configuration of analog input in <Input> tab). The maximum current is limited by the set phase current (see "Phase current" parameter in the <Motor Settings> tab).

The rotational speed is not fixed in this mode: the greater the load on the motor, the lower the rotational speed. The speed that is set depends on the type of motor used and the current setting.

Ramps are not used in the Torque mode. The rate at which the motor accelerates only depends on the setting for current.

Note:

The Torque mode can only be used when Closed Loop mode is activated.

5 <Motor settings> tab

Display

The general motor parameters are set in the <Motor Settings> tab.

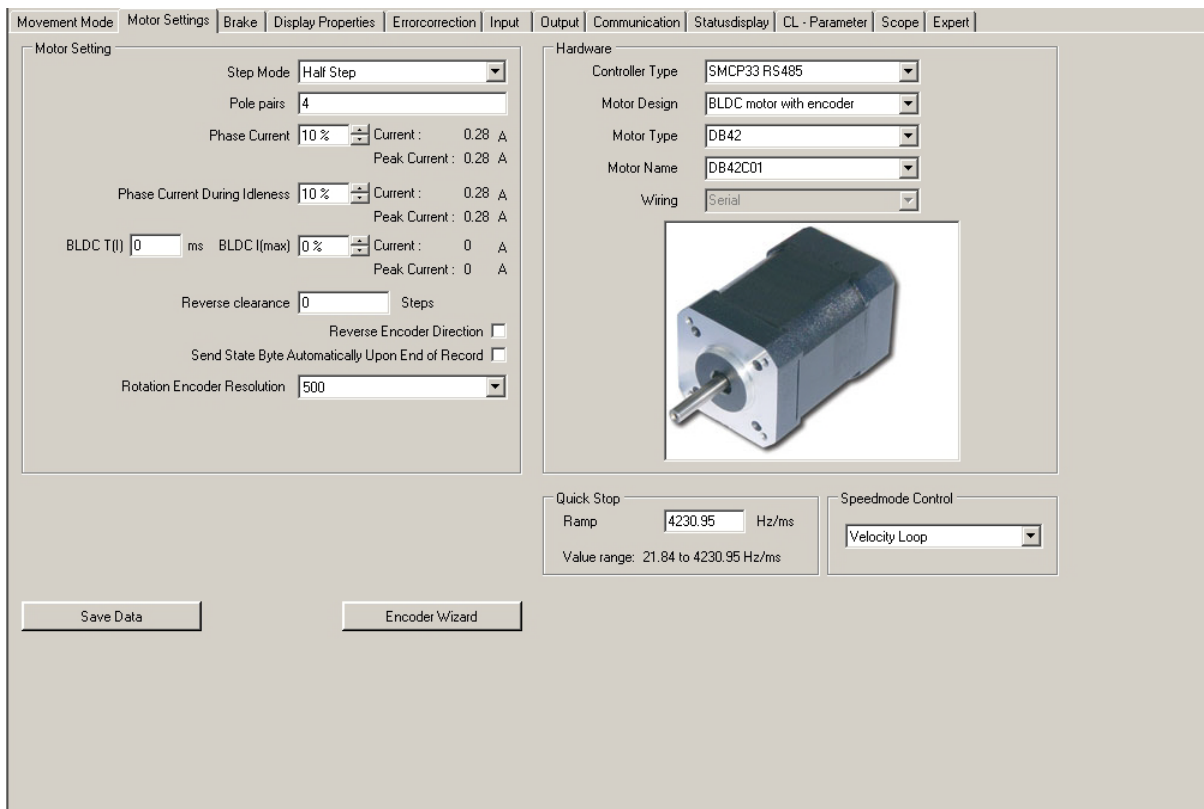

Parameter descriptions

The following parameters can be set for the motor:

Parameters	Function	Note
Hardware		
Controller Type	Selection of controller type.	The user interface is modified to correspond to the selected controller type.
Motor Design	Selection of the motor design of the connector motor.	When a BLDC motor is selected, the input field for the pole pair number is displayed instead of the selection field for the drive step angle in the motor settings area. Note: No stepper motor must be operated with the selected "BLDC motor" or "BLDC motor with encoder" setting. Otherwise, the motor could be destroyed during operation.

Parameters	Function	Note
Motor Type	Selection of the motor type.	
Motor Name	Selection of motor designation	
Wiring	Selection of the wiring (serial or parallel)	
Motor Settings		
Step mode	<p>The following step modes can be selected:</p> <ul style="list-style-type: none"> • Full Step • Half Step • Quarter Step • Fifth Step • Eighth Step • Tenth Step • 16th step • 32nd Step • 64th Step • Feed rate • Adaptive microstep (1/128) 	<p>The smaller the selected step size is, the larger the resolution:</p> <p>With 1.8° stepper motors, a half step is therefore 0.9° and a tenth step 0.18°, for example.</p> <p>Adaptive microstep means that the step angle is automatically enlarged at increasing speed.</p> <p>Example: at 30 rpm, the motor runs in 64th step mode and at 3000 rpm at full step as a higher speed is possible here and in general accuracy plays a subordinate role.</p> <p>In the Feed Rate mode, the number of full steps is defined by the feed rate.</p>
Drive Step Angle (Full Step step width) (not for BLDC motors)	Setting of the step angle of the connected motor.	<p>In general, the motor is a 1.8° stepper motor (default). Another step angle can be selected if necessary in the selection menu.</p> <p>Note: When a BLDC motor is selected, the input field for the pole pair number is displayed instead of the selection field for the drive step angle in the motor settings area.</p>
Pole pairs (only for BLDC motors)	Entry of the pole pair number of the connected motor.	Only displayed if a BLDC motor is selected.
Phase current	<p>The phase current can be set in steps of 1%.</p> <p>The corresponding absolute value is automatically calculated and displayed in the "Current" and "Peak Current" display fields.</p>	<p>The peak current is lower in the full step mode than in the other step modes. To provide the same power as in the full step mode, the motor requires a higher peak current at smaller step modes.</p>

Parameters	Function	Note
Phase Current During Idleness	Input of phase current at standstill in percent. The corresponding absolute value is automatically calculated and displayed in the "Current" and "Peak Current" display fields. It is recommended to select the highest possible current reduction for standstill.	This current reduction serves to minimize the heat generated by the dissipation loss of the motor windings and the output stage of the controller. When the full holding torque is required at a standstill, however, then the current reduction should not be activated and the phase current should not be reduced.
BLDC I (max)	Entry of the peak current for BLDC motors in percent.	The peak current must be at least as large as the phase current; otherwise, the phase current is used.
BLDC T (l)	Entry of the current time constants for BLDC motors in milliseconds.	The time constant defines the duration for which the set peak current can flow.
Reverse Clearance	Entering a number of steps to compensate for the backlash of the mechanics, e.g. for linear axes or gears.	The number of steps specified here is added every time the movement changes.
Send State Byte Automatically Upon End of Record	If this option field is activated, status bytes are automatically sent at the end of a run.	The use of this option is sensible if just one motor is actuated and the end of the run must be evaluated. Note: This option may not be used under any circumstances if a network is in use, as this could lead to conflicts and therefore to transmission errors.
Encoder Type	Encoder model used	The following types are available: <ul style="list-style-type: none"> • No encoder • Incremental with index • Incremental without index • Absolute single turn
Encoder Resolution	Resolution of the rotation encoder (pulses/revolution)	The following resolutions can be selected: 192, 200, 256, 400, 500, 512, 1000, 1024, 2000, 2048, 4000, 4096

Parameters	Function	Note
Reverse the encoder direction of rotation	Option field for activating the encoder direction of rotation.	In some cases a false direction of rotation is defined. This can be seen when the error message "Position error" is always displayed when testing records. This function can be used to change the A/B track in the software.
Feed Rate Numerator	<ul style="list-style-type: none"> Entry of the numerator of the feed rate. This value defines the number of steps per rotation of the motor shaft for the feed rate step mode. 	The feed rate is only used if numerator and the denominator are not equal to 0. Otherwise, the encoder resolution is used. Values for the feed rate that are not meaningful are not accepted when entered.
Feed Rate Denominator	<ul style="list-style-type: none"> Entry of the denominator of the feed rate. This value defines the number of steps per rotation of the motor shaft for the feed rate step mode. 	The feed rate is only used if numerator and the denominator are not equal to 0. Otherwise, the encoder resolution is used. Values for the feed rate that are not meaningful are not accepted when entered.
Gear factor Numerator/denominator	<ul style="list-style-type: none"> Entry of the numerator or denominator of the gear factor. The gear factor is used to take into account the step-up/reduction ratio of an upstream gear so that precisely the input travel profile is achieved at the gear output side. 	Unlike the feed rate, the gear factor is used for all travel modes. If the gear factor is 1, it has no effect. Value range for numerator and denominator: 1 to 255
Quick Stop Ramp	Ramp gradient for the Quick Stop function in Hz/ms.	Value range: 21.84 to 4230.95 Hz/ms
Speedmode Control	Selection of the control behavior in CL speed mode.	Please also refer to Section 13 "<CL-Parameter> tab (closed loop)".

Adjusting the encoder

Note:

- Before adjusting the encoder, the motor type or the motor step angle must be correctly set, see Section 5 "<Motor settings> tab".
- The <Encoder Wizard> button is only available for stepper motors (not BLDC).

Resolution and direction of rotation of the encoder can be adjusted using the <Encoder Wizard>.

The motor makes one revolution if the button is pressed. The resolution of the rotation encoder is automatically matched and displayed in the <Motor Settings> tab. Depending on the connection, the rotation is also matched if necessary and displayed in the <Motor Settings> tab ("Reverse Encoder Direction" checkbox is activated).

6 <Brake> tab

Display

Settings for the brake are adopted using the <Brake> tab.

External Brake

Time ta: ms

Time tb: ms

Time tc: ms

The external brake can be configured by three parameters:
ta, tb, tc

The parameters define times (ms). Possible values are 0-65535.

Power up sequence:

When the Controller is turned on, the brake is active and the drive is not under current.
Then the drive is set under current and the controller will wait for ta ms.
Then the brake is disabled and the controller waits for tb ms.
After tb the controller is accepting drive commands.

tc is the time between activating the brake and disabling the drive current.

Save Data

Start

Motor

Bremse

geschlossen

geöffnet

Zeit

ta

tb

tc

Parameters for external brake

The following parameters can be set:

- Time ta:
Waiting time between switching on the motor current and switching off (triggering) the brake in milliseconds.
- Time tb:
Waiting time between switching off (triggering) the brake and activation of readiness in milliseconds. Travel commands will only be executed after this waiting time.
- Time tc:
Waiting time between switching on the brake and switching off the motor current in milliseconds.

The parameters indicate times between 0 and 65,536 milliseconds.
Default values of the controller after a reset: 0 ms.

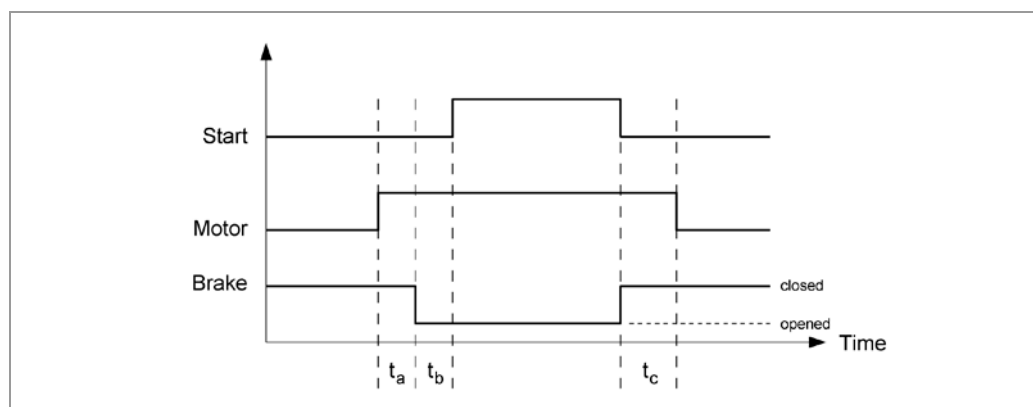

Braking response

When switching on the controller, the brake becomes active first and the motor is not provided with power.

Note:

During current reduction, the brake is not actively connected.

7 <Display Settings> tab

Display

Display properties are made using the <Display Properties> tab.

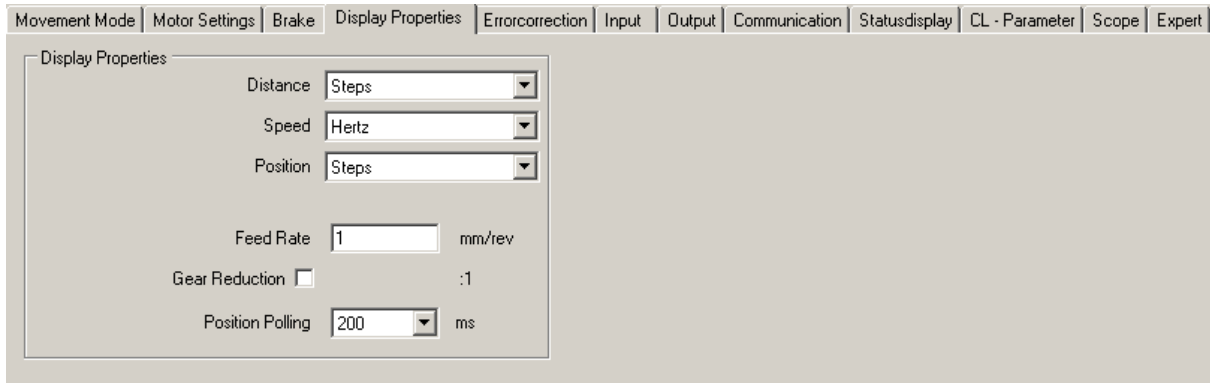

Display Properties

The following parameters can be set:

Parameters	Function	Note
Distance	The distance can be displayed in: <ul style="list-style-type: none"> • Steps • Degrees • mm 	The units of measure set here are inserted in the parameter fields of the various operating modes.
Speed	The speed (rotational speed) can be displayed in: <ul style="list-style-type: none"> • Hz • rpm • mm/s 	The units of measure set here are inserted in the parameter fields of the various operating modes.
Position	The counter reading can be displayed in: <ul style="list-style-type: none"> • Steps • Degrees • mm 	The units of measure set here are inserted in the parameter fields of the various operating modes.
Feed rate	Definition of the feed rate in mm/rev.	If one of the above parameters is set to "mm", then the corresponding feed must be entered in the "Feed Rate" field.
Gear reduction	Option field for activating the "Gear Reduction" field. Input of the gear reduction when the field is activated.	When the option field is set, the field "Gear Reduction" is activated and the reduction value can be entered. 
Position Polling	Update interval for the ramp graph in ms in the <Movement Mode> tab.	On older computers it can make sense to set a high value. The default setting is 200 ms.

8 <Errorcorrection> tab

Display

The settings for speed monitoring and error correction are made on the <Errorcorrection> tab.

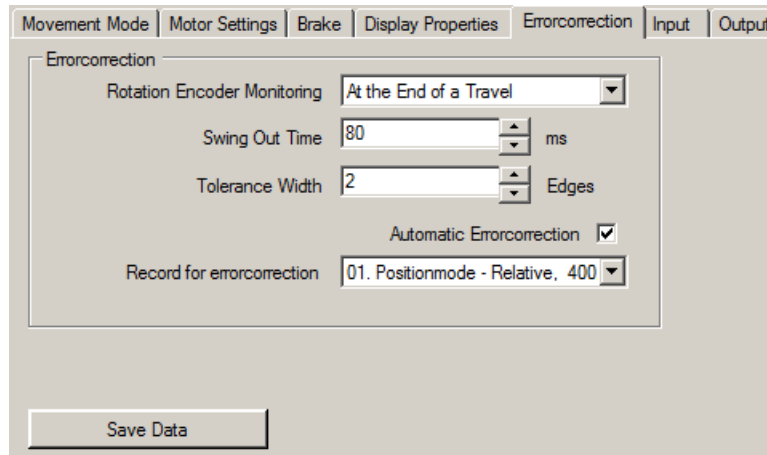

The screenshot shows the <Errorcorrection> tab of the NanoPro software interface. The tab is selected, and the settings are as follows:

- Rotation Encoder Monitoring: At the End of a Travel
- Swing Out Time: 80 ms
- Tolerance Width: 2 Edges
- Automatic Errorcorrection:
- Record for errorcorrection: 01. Positionmode - Relative, 400

A "Save Data" button is located at the bottom of the tab.

Motor function test

The motor has an integrated encoder signal evaluation for checking motor functions and to signal step losses. If the motor loses more than 1 half step (0.9° with a 1.8° stepper motor), output 2 signals an error.

It is possible to compensate for this error at the end of or during the run.

Parameter descriptions

The following parameters can be set for the motor:

Parameters	Function	Note
Rotation Encoder Monitoring	The following modes can be selected: <ul style="list-style-type: none"> • Deactivate • At end of run • During run 	"Deactivate" means that the encoder monitoring has been switched off. All fields in this area are switched to inactive. The "Disable" mode must be selected if no encoder is being used. The rotation encoder monitoring mode checks the position of the rotor at the end of the run (after the swing out time) or during the run. As described above, the position of the rotor can also be checked and corrected, if necessary, at the end of the run if the "Automatic Error Correction" option field is activated.
Swing Out Time	Definition of a settling time in 1-ms steps; the time that the encoder waits before it measures the position of the rotor. The recommended standard value is 80 ms.	After a record is completed, the rotor swings out around the set target position before it comes to a standstill. This settling is taken into account by a settling time to prevent the risk of faulty measurements. The settling time decreases the smaller the moment of inertia of the rotor, and other external moments of inertia are, and the larger the damping, system rigidity and friction are.
Tolerance Width	Input of a tolerance within the encoder edges. The recommended standard value is 2 edges.	The tolerance is the maximum deviation in (micro)steps. How large a step is depends on the currently set step mode. If the encoder resolution is insufficient (step mode > 1/10 in 1.8° motors, or. >1/5 in 0.9° motors), additional errors will result from the conversion of encoder increments into microsteps.
Automatic Errorcorrection	Option field for activating the automatic error correction.	At the end of a record, the controller calculates the lost steps and compensates for them with a defined correction run. The parameters must be selected so that the controller safely implements the correction without losing any steps. When the setting is made during the run, the correction will be implemented during the run itself.
Record for correction run	Selection menu for definition of travel profile used for "Automatic Errorcorrection" (activated option field, see above).	The ramp and the speed from the travel profile selected here are used for the correction run.

Starting within the swing out time

The specification of a swing out time before measurement of the rotor position by the encoder limits the possibility of rapid reversing movements.

In the relative positioning mode, a break between two reversing rotary motions must also be defined (minimum = 1 ms). If the set break is shorter than the swing out time, the motor waits until the rotor is in a suitable position and then carries out the next record. This "favorable position" is determined when the tolerance width is set and avoids step losses.

The length of the break and swing out time (in ms) after the completion of a record is determined by the number of encoder edges. It is possible to realize rapid reversing movements with the specification of a tolerance width (in edges).

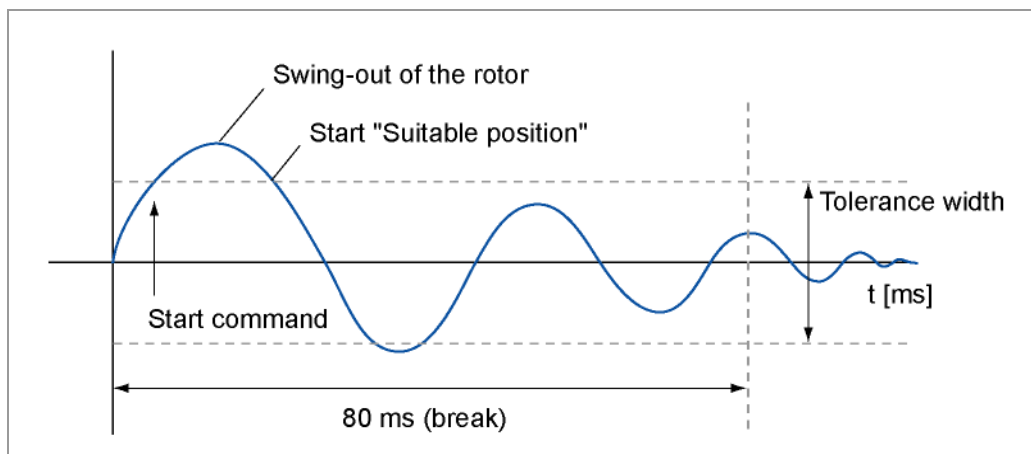

Encoder edges

The encoder has a 5 to 10 times higher resolution than the motor. The encoders used operate with 500 pulses/revolution.

This squaring results in a resolution of 2,000 edges.

The 1.8° stepper motors operate with 200 steps/revolution, therefore a full step equals 10 encoder edges (half step = 5 edges).

The recommended tolerance width is 2 edges.

9 <Inputs> tab

Display

Analog input,

The <Input> tab, the following parameters for the analog input can be defined:

Parameters	Function
Lower voltage threshold and Upper voltage threshold	<p>These values determine the upper and lower limits of the input voltage.</p> <p>The voltage is resolved with an accuracy of 10 bits. The smaller the selected range is, the worse the resolution of the speed will be (and vice versa):</p> <ul style="list-style-type: none"> • Start speed: lower limit • Setpoint speed: upper limit • Maximum range: -10 V ... +10 V. <p>Calculation example Selected voltage range = 0 V to +5 V Start speed = 400 Hz = 0 V Setpoint speed = 1000 Hz = +5 V Speed adjustable: $10 \text{ bit} = 1024 = 5 \text{ V} / 1024 = 0.0048 \text{ V}$ corresponds to 2.344 Hz (400 Hz - 1000 Hz = 600 Hz / 256 = 2.344 Hz). The divisor "256" in the above equation is derived from the percentage of the voltage range used: The voltage range of 5 V out of a possible range of 20 V equals 25%. Based on the 10 bit resolution, this is equal to 25% of 1024 = 256.</p>

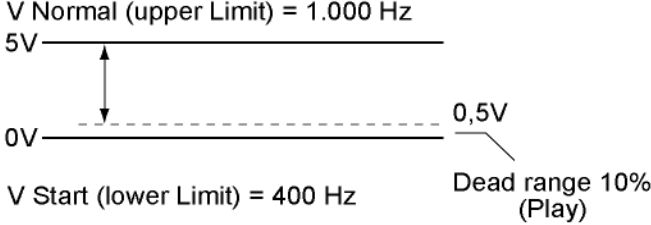
Parameters	Function
Play (dead range)	<p>The "Play" setting provides an option to hide the interference or ripple voltage in the lower limit range.</p> <p>A play of 10% would limit the control range to 0.5 – 5.0 V with a lower limit of 0 V and an upper limit of 5 V.</p> <div style="text-align: center;">  </div> <p>Calculation example for play: Selected voltage range = 0.5 V to +5 V Start speed = 400 Hz = 0.5 V Setpoint speed = 1000 Hz = +5 V Speed adjustable: 10 bit = 1024 = 4.5 V / 1024 = 0.0044 V corresponds to 2.604 Hz (400 Hz - 1000 Hz = 600 Hz / 230.4 = 2.604 Hz). Divisor from the percentage of the voltage range used: The voltage range of 4.5 V out of a possible range of 20 V equals 22.5 %. Based on the 10 bit resolution, this corresponds to 22.5% of 256 = 230.4.</p>
Filter Time constant / hysteresis	<p>The analog input samples the input voltage with a frequency of 1 kHz. The input voltage can be smoothed with the help of the analog input.</p> <p>A filter value between 0 and 16 results in a simple average value formation over the given number (a value of 0 or 1 indicated that averaging has not occurred).</p> <p>As filtering only takes 16 milliseconds with a sample frequency of 1 kHz over maximum 16 supporting points, it is possible to use a recursive filter where the determined value depends on the actually measured value and on the previous "filter value". This method can be used to average a greater number of supporting points, even if insufficient memory is available. However, this is not a real average value, but a signal rounding of the input voltage (first order low pass or PT1 element).</p> <p>The recursive filter is used from a value of 17. The first 4 bits of the value as a power of 2 define the time constant T in ms (time after which the filter output has approached the filter input to within 50%) and the last 4 bits of the value define the hysteresis (maximum change of the value at the filter input toward which the filter output is insensitive). The two components of the filter setting can be separately set using the two sliders; the corresponding total value is automatically entered in the "Filter" field. The following table shows the values of the time constant for a hysteresis of 0.</p> <p>With an input jump from 0 to 1, the filter output follows the following rule: $Output = 1 - (0.5)^{t/T}$ where t is the time along the x axis and T the time constant of the filter.</p>

Parameters	Function		
	<p>5*T after changing the input voltage, the value at the filter output has thus reached 97% of the input value.</p> <p>10*T after changing the input voltage, the value at the filter output will have reached 99.9% of the input value. The deviation corresponds to one stage of the AD converter when the input changes cover the entire range, e.g. a jump from -10 V to +10 V.</p>		
	Value	Time constant T	Time for 99.9%
	17	1 ms	10 ms
	18	2 ms	20 ms
	19	4 ms	40 ms
	20	8 ms	80 ms
	21	16 ms	160 ms
	22	32 ms	320 ms
	23	64 ms	640 ms
	24	128 ms	1.2 s
	25	256 ms	2.6 s
	26	512 ms	5.1 s
	27	1 s	10 s
	28	2 s	20 s
	29	4 s	40 s
	30	8 s	80 s
	31	16 s	160 s

Behavior for Internal / External Homing

There are various options for defining behavior at the external and internal limit switches:

- "Free backwards" (reference run and normal operation)
- "Free forwards" (reference run and normal operation)
- "Stop" (only for normal operation)
- "Disable" (only for normal operation)

"Free backwards"

The motor changes direction on recognition of the limit switch and leaves the limit switch.

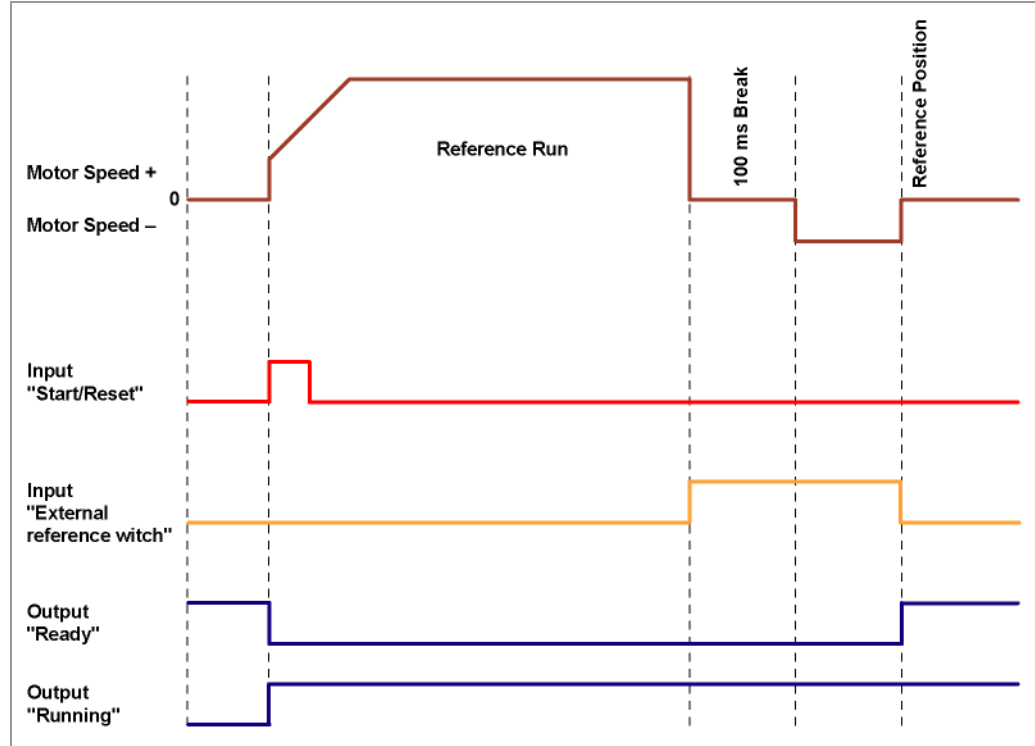

"Free forwards"

The motor continues in the same direction after recognizing the limit switch and leaves the limit switch.

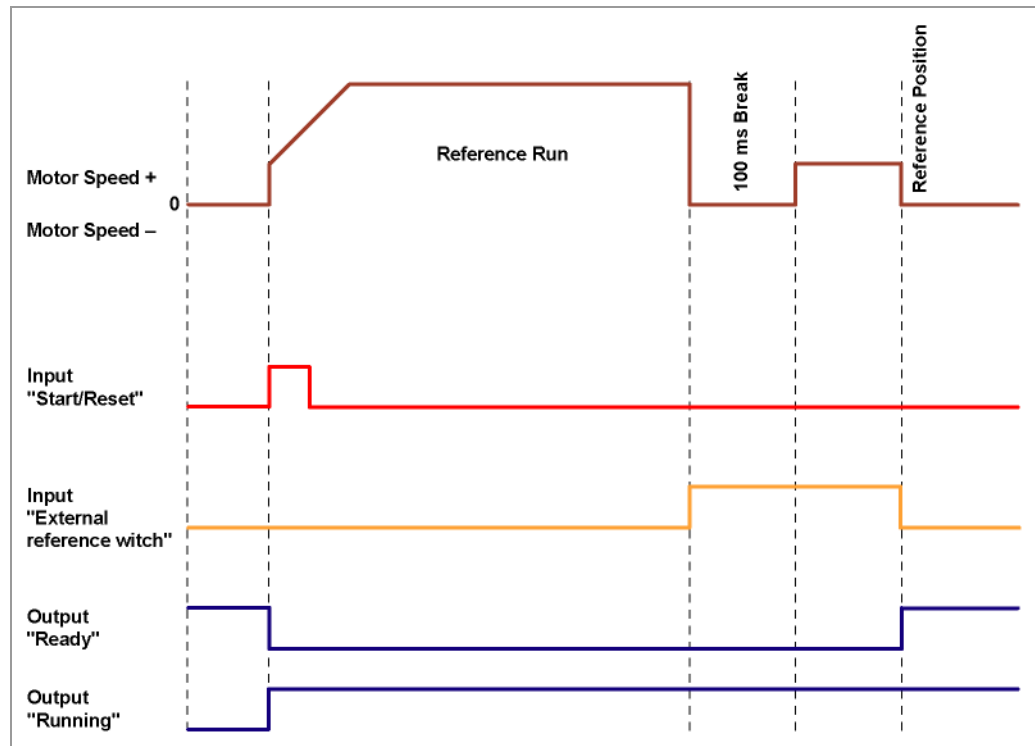

"Stop"

The motor immediately stops upon recognition of the limit switch. A reference run must then be implemented as the motor may have lost steps (overflow).

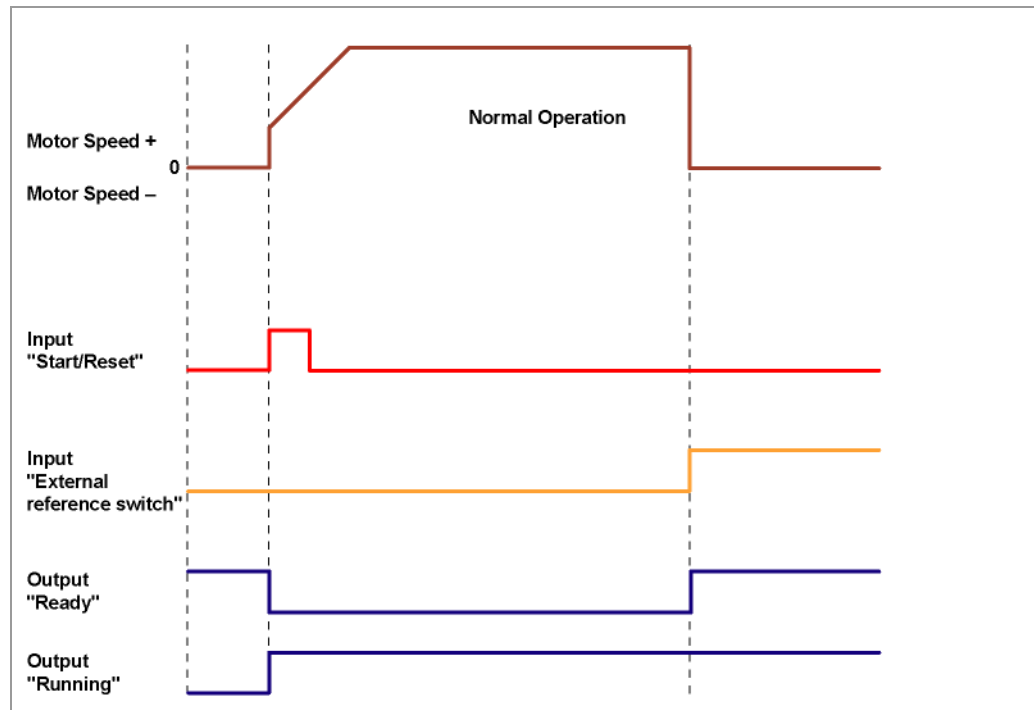

"Disable"

The limit switch has no function.

The following parameters can be set:

Parameters	Function
Type	Selection of the reference switch as an opener or closer depending on the version.
During Homing	Data on whether the limit switch (external and internal) should be approached during the reference run free forwards (without direction change) or backwards (in the opposite direction).
During Normal Operation	Data on how the motor should behave when recognizing the limit switch (external and internal) during normal operation (no reference run).

Procedure

Proceed as follows to set the limit switch behavior:



Step	Action	Note
1	Select the <Input> tab.	
2	Set the parameters according to your requirements.	
3	Click on the <Save Data> button.	The settings are saved.

Inputs

The following settings can be made:

Switching behavior

A selection can be made for each input as to whether it switches with rising or falling edge:

-  = falling edge
-  = rising edge

Input function

- User defined:
 The input is "masked", i.e. it is not directly interpreted by the controller and is available to the user as a "general purpose" input.
 The masking of an input means that its state (high/low) can be evaluated via the interface.
 Further information can be found in the relevant "Command Reference" section of the programming manual.
- Start/reset:
 An impulse at the Start/Reset input starts the selected travel profile. A negative edge at Start/Reset input can be used to reset an error (speed monitoring).
- Record bit 0 to record bit 4:
 The profile numbers are called up using a binary code with the inputs record bit 0 to record bit 3. When the Start/Reset input is activated, the value is read in and the corresponding profile is loaded and started.

Profile number	Record bit 0	Record bit 1	Record bit 2	Record bit 3	Record bit 4
1	0	0	0	0	0
2	1	0	0	0	0
3	0	1	0	0	0
...
31	0	1	1	1	1
32	1	1	1	1	1

- External reference switch:
 See "End switch behavior, internal/external" and the separate manual for the respective stepper motor controller or for the Plug & Drive motor.
- Direction:
 The Direction input determines the direction of rotation of the motor.
 In the Joystick mode, the direction of the motor depends on the defined voltage range. The direction is changed in the middle of the voltage range (e.g. at +5 V in a voltage range of 0 V to +10 V).
- Enable
- Clock (input 6 only):
 With every positive edge at the clock input, in the Clock direction mode the motor carries out a step in the direction set by the direction input. The external clock is also active for the reference runs.
- Clock direction mode, mode selection 1/2:
 The mode is defined with the clock direction mode, mode selection 1/2 inputs. The setting is accepted when the Start/Reset input is activated. The direction of the reference runs is specified by the saved parameters. In the clock direction left/right modes, the motor travels 10 steps with a frequency of approx. 2 Hz and then accelerates to the programmed maximum frequency.

Mode selection

Operation mode	Clock direction mode, mode selection 1	Clock direction mode, mode selection 2
Clock Direction Left	0	0
Clock Direction Right	1	0
Clock Direction Run Int. Ref.	0	1
Clock Direction Run Ext. Ref.	1	1

State Display

In addition, the state of the inputs present when the tab was opened is displayed (green = high, red = low).

Input Debounce Time

Sets the time in ms that needs to elapse after a signal change at an input until the signal has stabilized.

Activate Input Polling

The status display of the inputs is activated if the checkbox is activated.

10 <Outputs> tab

Display

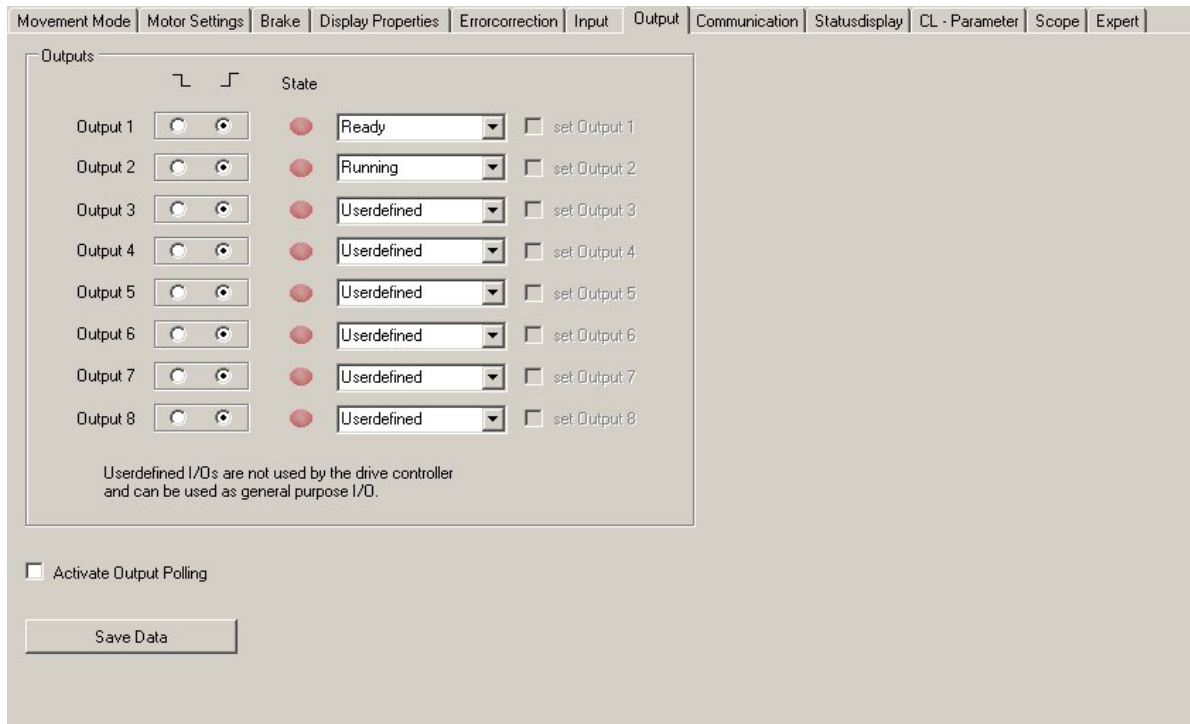

Output	Switching Behavior	State	set Output
Output 1	<input checked="" type="radio"/> Falling edge	Ready	<input type="checkbox"/>
Output 2	<input checked="" type="radio"/> Falling edge	Running	<input type="checkbox"/>
Output 3	<input type="radio"/> Falling edge / <input checked="" type="radio"/> Rising edge	Userdefined	<input type="checkbox"/>
Output 4	<input type="radio"/> Falling edge / <input checked="" type="radio"/> Rising edge	Userdefined	<input type="checkbox"/>
Output 5	<input type="radio"/> Falling edge / <input checked="" type="radio"/> Rising edge	Userdefined	<input type="checkbox"/>
Output 6	<input type="radio"/> Falling edge / <input checked="" type="radio"/> Rising edge	Userdefined	<input type="checkbox"/>
Output 7	<input type="radio"/> Falling edge / <input checked="" type="radio"/> Rising edge	Userdefined	<input type="checkbox"/>
Output 8	<input type="radio"/> Falling edge / <input checked="" type="radio"/> Rising edge	Userdefined	<input type="checkbox"/>

Userdefined I/Os are not used by the drive controller and can be used as general purpose I/O.

Activate Output Polling

Save Data

Note: The number of outputs depends on the controller in use.

Settings

The following settings can be made:

Switching behavior

A selection can be made for each output whether it switches with rising or falling edge:

- = falling edge
- = rising edge

Output function

- User defined:
The output is "masked", i.e. it is not directly interpreted by the controller and is available to the user as a "general purpose" output.
- Ready
- Running

- Error
The error state cannot be displayed in NanoPro.
The "Activate Polling Output" checkbox has no effect.
The entry in the selection menu can, however, be used to configure external I/Os.

"Error"	"Ready"	"Running"	State
1	X	X	The motor cannot travel. The error needs to be rectified first.
0	0	1	The motor is processing the last command.
	1	0	Motor idle, waiting for new command.
	0	0	Error (speed monitoring) or limit switch (normal operation).
	1	1	Reference point (zero position) reached.

Setting the output

When the checkbox is activated, the corresponding output of the firmware is set provided it is masked for open use.

State Display

In addition, the state of the outputs present when the tab was opened is displayed (green = high, red = low).

Activate Output Polling

The status display of the outputs is activated if the checkbox is activated.

11 <Communication> tab

Display

The settings for interface parameters and the motor address made on the <Communication> tab:

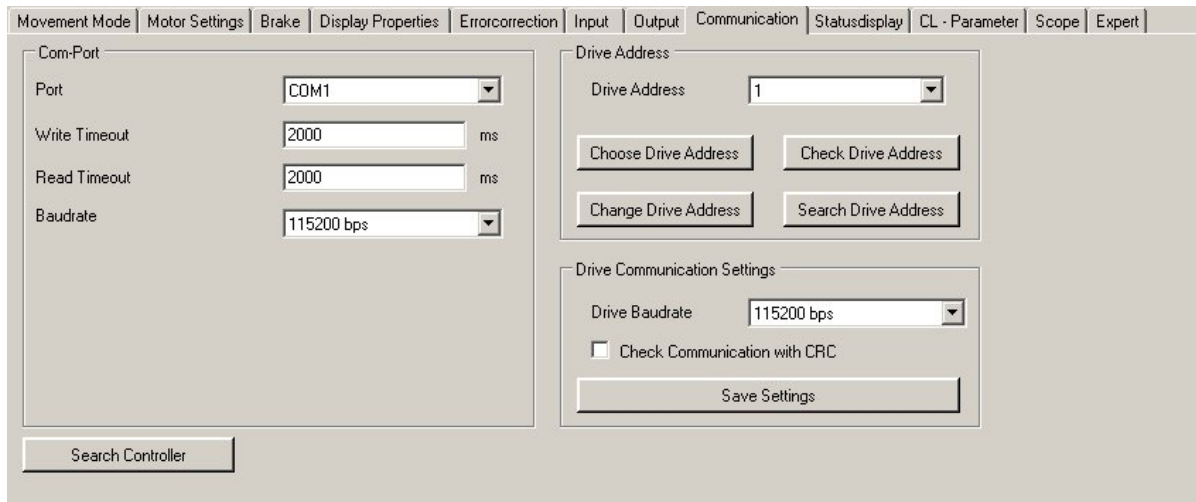

Interface parameters

The following interface parameters can be set:

Parameters	Function
Interface	In the "Port" field, select the COM port to which the motor is connected. <ul style="list-style-type: none"> The number of the COM port to which the motor is connected can be found in the device manager of your Windows PC.
Write/Read Timeout	Maximum timeout in milliseconds when transferring data to/from the controller.
Baudrate	Data transfer rate in bits per second.

Setting the drive address

To ensure a fault-free connection with the motor, the motor address (module address) must be set correctly. All motors are delivered with the default address "1". To operate more motors in an RS485 network, each motor must be assigned a unique address.

The following functions are available in this menu:

- <Check Drive Address>
Press the button to check whether a motor is connected to the currently configured motor address.
- <Search Drive Address>
Prerequisite: Only one motor is connected.
The address of the connected motor is adopted.
- <Change Drive Address>
Prerequisite: Only one motor is connected.
The "drive address" configured in the selection menu is assigned to the motor.
- <Choose Drive Address> The address configured in the "Drive Address" selection menu is transferred to the "Motor" selection menu (menu bar).

Change Drive Baudrate

Select the required baud rate from the "Drive Baudrate" selection menu and then click on the <Save Settings> button to transfer the new setting.

Activating the communication check with CRC

Activate the "Check Communication with CRC" checkbox and then click on the <Save Settings> button to verify communication between the PC and controller using a checksum.

Search Controller

When the <Search Controller> button is activated, all COM ports and baud rates are run through until a controller is found.

12 <Status display> tab

Introduction

The <Statusdisplay> tab can display general status messages, stored error entries and programming settings can also be made.

<Statusdisplay> tab

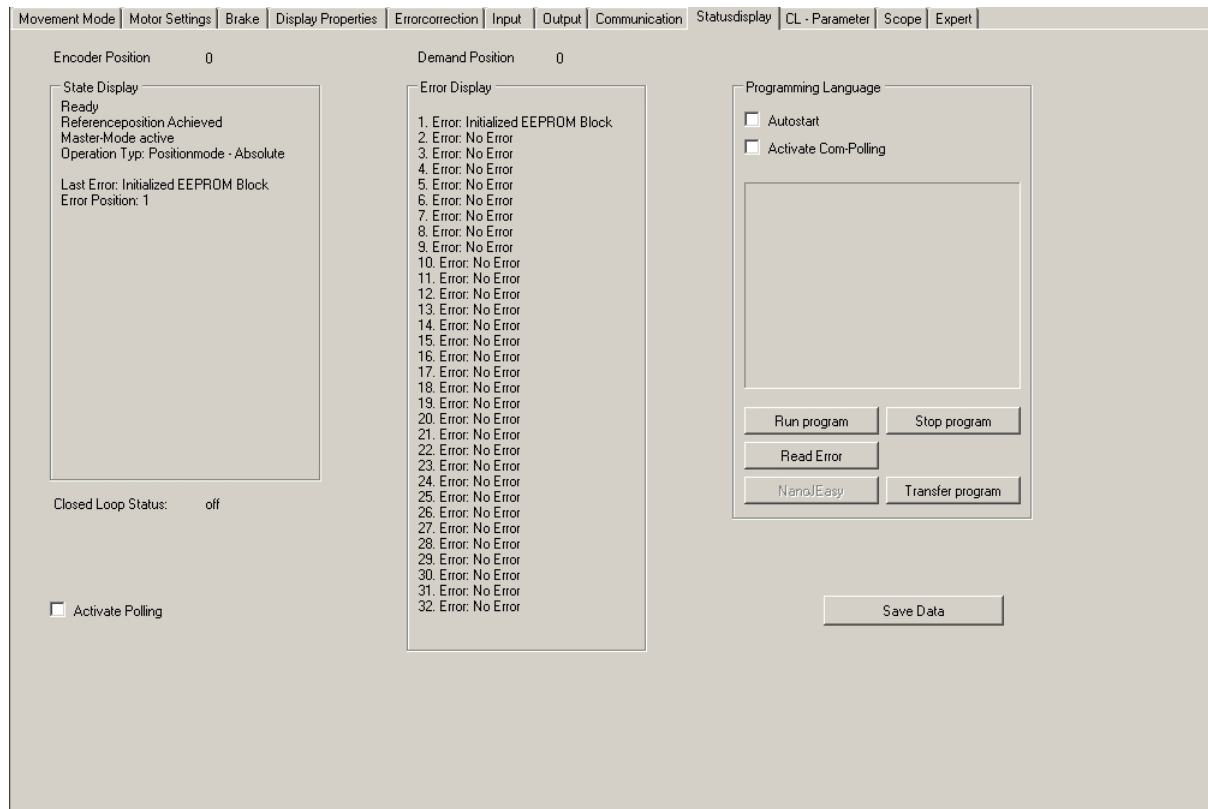

Display

The <Statusdisplay> tab contains the following displays:

Display	Function
Encoder Position	Actual encoder position (if an encoder is connected)
Demand Position	Current setpoint position of the motor
State Display	Actual mode, state and last error entry
Closed Loop Status	Indicator of whether closed loop mode is active
Controller temperature	The current measured temperature inside the controller. The temperature is only displayed if the current firmware supports reading out of the temperature. From firmware version: 21-10-2012
Error Display	Error memory for the last 32 errors. Note: After the controller is switched on, the "Undervoltage" error message appears with the error position 13. Because the undervoltage occurs with the last switch-off of the controller, this error message is entirely normal.

Activating the status display

Proceed as follows to activate the motor status:

Step	Action	Note
1	Select the <Statusdisplay> tab.	
2	Activate the "Activate Polling" checkbox.	

Programming settings

Controllers can be programmed via JAVA (NanoJEasy) or via the COM interface, see the programming manual.

The following settings can be made in the "Programming Language" area:

Setting	Function
Autostart	When the checkbox is activated, the loaded program is automatically executed if the motor is powered.
Activate Com-Polling	If this checkbox is activated, any responses of the executed program via the COM interface are displayed in the field under the checkbox.
Start program/Stop program	Starts/Stops the loaded program.
Read Error	Displays the last entry of the error memory.
NanoJEasy	Open the NanoJEasy editor (if installed).
Transfer program	Transfer the program to the controller.

13 <CL-Parameter> tab (closed loop)

13.1 Configuring the closed loop current control

Function

In the Closed Loop mode, the motor does not behave like a normal stepper motor, but instead like a servomotor. It is controlled via a PID controller dependent on an encoder.

The controller includes two controllers and each controller has its own parameter set.

<CL-Parameter> tab

Settings for the closed loop current control are made via the <CL-Parameter> tab.

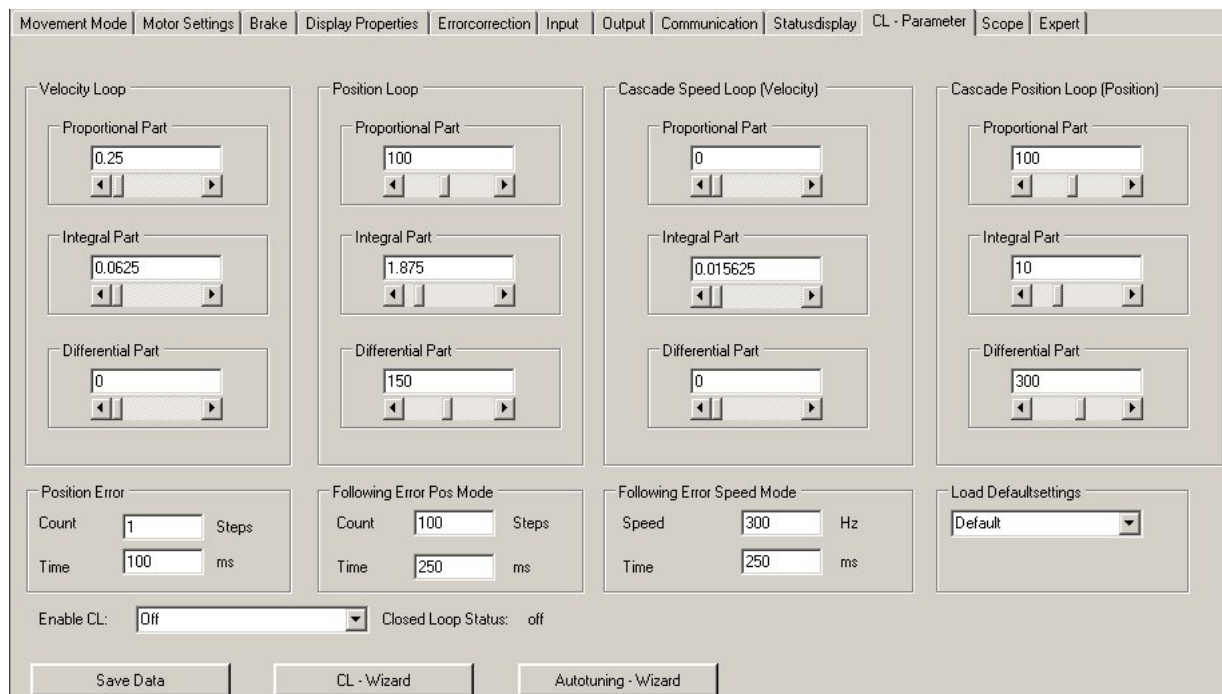

Procedure

Proceed as follows to configure the closed loop current control:

Step	Action	Note
1	Select the <CL-Parameter> tab.	
2	In the "Load Defaultsettings" field, select the motor size (e.g. ST41xx)	
3	Run the Closed Loop wizard in the "CL - Wizard" button.	CAUTION! Motor makes several revolutions. See Section "CL - Wizard".
4	Run the Autotuning Wizard in the <Autotuning-Wizard> button.	The wizard empirically determines suitable CL parameters. Alternatively, you can also enter them manually as described in Step 5.

Step	Action	Note
5	Enter the desired parameters.	Detailed information on the parameters can be found the following sections.
6	Click on the <Save Data> button.	The settings are saved.

13.2 Velocity loop

Description

The speed controller controls the angle speed of the shaft. The position in this mode is not controlled and can therefore deviate greatly from the setpoint.

The speed controller is used in the following operation modes:

- Speed mode
- Analog mode
- Joystick mode
- Rotor position measurement

Internal calculation principles and parameters

The controlled variables in the speed controller are always based on the actual speed in revolutions per minute (rpm). The set parameters are used to convert the system deviation (deviation of actual speed from setpoint speed) into the control variable (current level).

The control variable of the speed controller is determined with the following equation:

$$u_n = KP * e_n + I_{n-1} + KI * e_n + KD * (e_{n-1} - e_n)$$

The next integral value is derived from:

$$I_n = I_{n-1} + KI * e_n$$

u_n	Control variable
KP	Proportional component derived from the numerator/ $2^{\text{denominator}}$
KI	Proportional component derived from the numerator/ $2^{\text{denominator}}$
KD	Proportional component derived from the numerator/ $2^{\text{denominator}}$
e_n	Deviation of actual value from setpoint value
e_{n-1}	Deviation of previous actual value from previous setpoint value
I_{n-1}	Last integral value

Speed error monitoring

The speed controller monitors the set speed. If the actual speed deviates for a specific time from the setpoint speed, the controller is deactivated and the motor stops.

The speed monitoring can be adjusted as required with the parameters in the "Following Error Speed Mode" area:

- "Count" The maximum amount-based deviation of the actual from the setpoint position is output in steps (value range: 0 - 2000000000).
- "Time" Time is output in milliseconds.

13.3 Position loop

Description

The position controller controls the position. It is used in the following modes:

- Relative/Absolute Position Mode
- Flag Position mode
- Clock Direction mode
- Analogue Position mode
- Reference run

Internal calculation principles and parameters

With the position controller, the controlled variables always refer to the actual position deviation in steps. The set parameters are used to convert the system deviation (deviation of actual position from setpoint position) into the control variable (current value).

The control variable of the position controller is determined with the following equation:

$$u_n = KP * e_n + I_{n-1} + KI * e_n + KD * (e_{n-1} - e_n)$$

The next integral value is derived from:

$$I_n = I_{n-1} + KI * e_n$$

u_n	Control variable
KP	Proportional component derived from the numerator/ $z^{\text{denominator}}$
KI	Proportional component derived from the numerator/ $z^{\text{denominator}}$
KD	Proportional component derived from the numerator/ $z^{\text{denominator}}$
e_n	Deviation of actual value from setpoint value
e_{n-1}	Deviation of previous actual value from previous setpoint value
I_{n-1}	Last integral value

Reaching the end position

If the position controller is active, the motor will only signal that it is ready after the end of a run when the measured position remains within a tolerance window for a specific time.

The tolerance width and the minimum time can be set with the parameters in the "Position Error" area:

- "Count" The maximum amount-based permissible deviation from the end position is output in steps.
- "Time" The minimum time in milliseconds that the motor must stay at the corresponding position before it signals that it is "ready".

Position error monitoring

The position controller monitors the set position at all times (even following errors are recorded during travel). If the actual position deviates by a specific value from the setpoint position, the controller is deactivated and the motor stops.

The position monitoring can be adjusted as required with the parameters in the "Following Error Pos Mode" area:

- "Count" The maximum amount-based deviation of the actual position from the setpoint position is output in steps. (Value range: 0 - 2000000000).
- "Time" Time is output in milliseconds.

Help for setting the control parameters of the position controller

To adjust the parameters, it is necessary to apply the load that the controller later needs to control to the motor. It does not make sense to set the controller for an unloaded motor as the behavior will change completely when the load is applied to the motor.

The following table shows possible problems and countermeasures:

Problem	Countermeasures
Motor oscillates up or too long afterwards.	<ul style="list-style-type: none"> • Reduce I-component • Increase D-component • Increase P-component
Motor "cracks" during the run.	<ul style="list-style-type: none"> • Reduce D-component • Possibly reduce P-component
Motor takes too long to reach the end position.	<ul style="list-style-type: none"> • Increase I-component • Increase P-component
Motor compensates for static loads too slowly.	<ul style="list-style-type: none"> • Increase I-component
Motor signals position error.	<ul style="list-style-type: none"> • Increase permissible following error ("Following Error Pos Mode"). • Operate controller more firmly (increase P-component, increase I-component). • Decrease maximum speed. • Increase phase current. <p>CAUTION! Note maximum motor current. A new rotor position initialization may be necessary.</p>
Motor not accelerating as fast as the set ramp (possibly combined with a position error during the acceleration phase).	<ul style="list-style-type: none"> • Increase phase current. <p>CAUTION! Note maximum motor current.</p> <ul style="list-style-type: none"> • Set a slower ramp. • Use a stronger motor (with appropriately set phase current).

Cascade controller,

The cascade controller consists of two closed loops: an internal closed loop that controls the speed, and an external closed loop that controls the position. The outer control loop does not directly control the motor current, but the setpoint (set speed) of the inner control loop.

The autotune wizard can also be used to empirically determine the control parameters for the cascade controller.

CL - Wizard

Start the closed loop wizard with which the closed loop mode can be set up using the <CL - Wizard> button.

	<p>CAUTION! Motor makes several revolutions.</p> <ul style="list-style-type: none"> Ensure that a motor is connected. Check the interface parameters in the <Communication> tab!
-----------------------------------------------------------------------------------	------------------------------------------------------------------------------------------------------------------------------------------------------------------------------------------------------------------------------------

Proceed as follows:

Step	Action
1	Click on the <CL - Wizard> button. The following window appears: <div style="border: 1px solid black; padding: 10px; margin: 10px 0;">  </div>

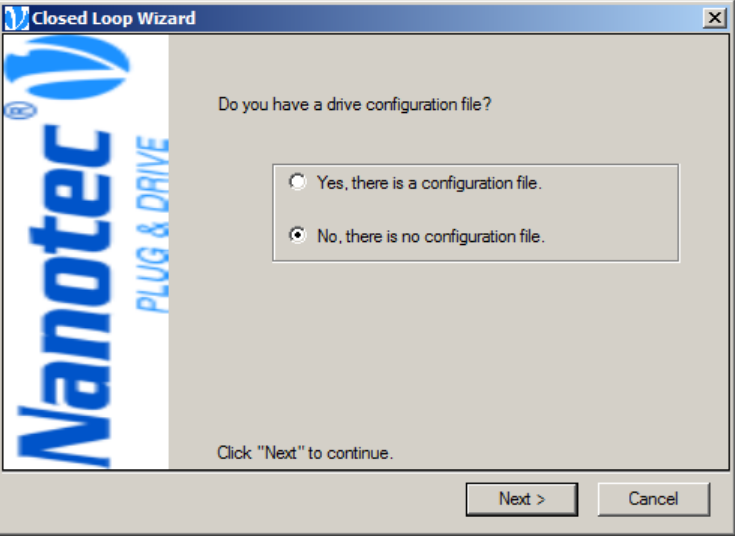
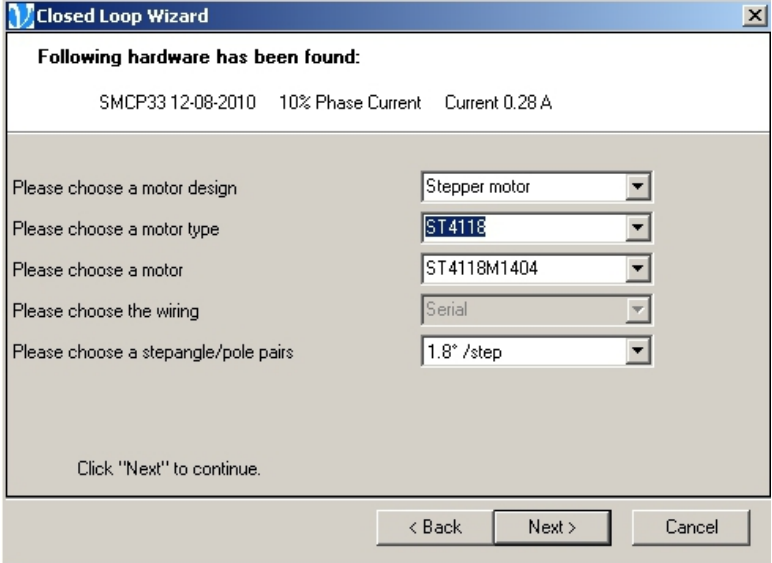
Step	Action
2	<p>Click on the <Next> button. The following window appears:</p> 
3	<ul style="list-style-type: none"> • If a configuration file already exists: Select the upper option field and then click on the <Next> button. The "Open" window appears, in which you can select the configuration file. • If configuration file still does not exist: Click on the <Next> button. A search is made for connected hardware. The following window appears if hardware has been found:  <p>Check whether the hardware has been detected correctly and change the motor design, motor type, connection type and step angle/pole pair number if necessary.</p>

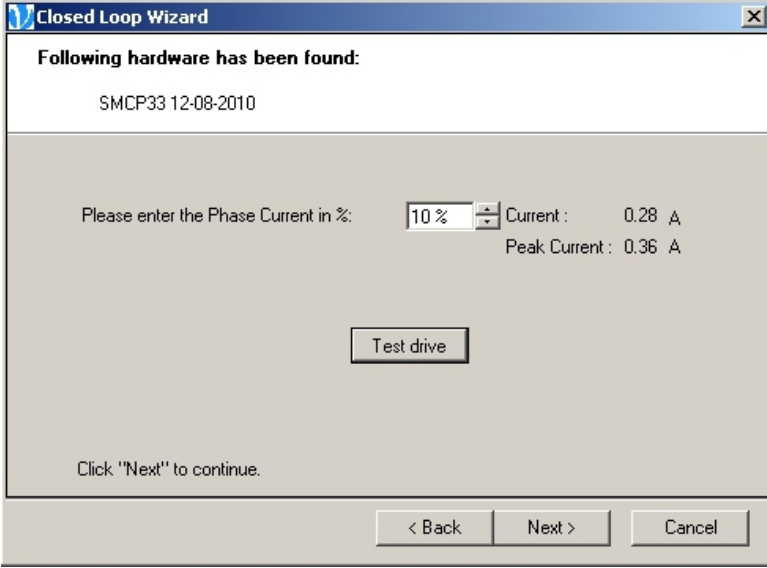
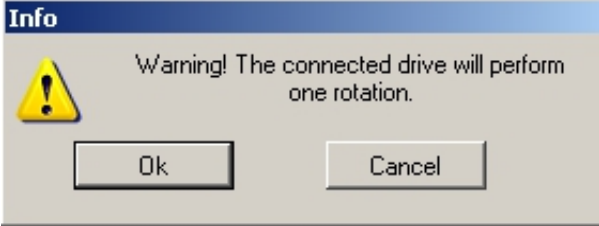
Step	Action
4	<p>Click on the <Next> button. The following window appears:</p>  <p>Specify the phase current in %.</p> <p>Note: An excessively high phase current can damage your motor. See the phase current data in the data sheet of your motor.</p>
5	<p>Click on the <Test drive> button if necessary. The following window appears:</p>  <p>Click on the <Ok> button: An attempt is made to move the motor by one rotation using the specified parameters. Click on the <Cancel> button to abort the motor test.</p>

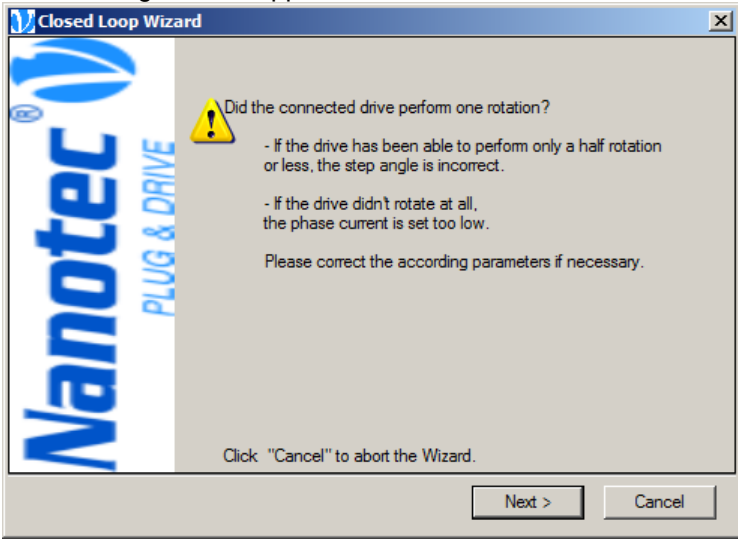
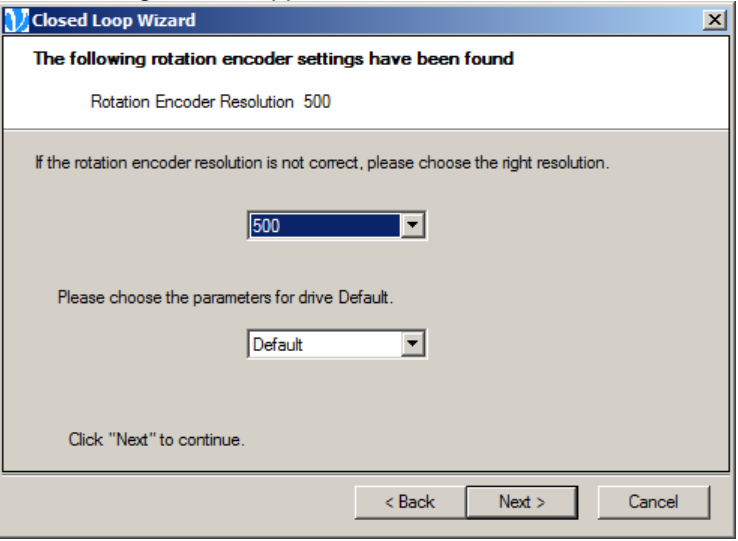
Step	Action
6	<p>The following window appears after the motor test:</p>  <p>Check whether the connected motor has made a full revolution. Change the settings for the step angle or motor current if necessary.</p> <p>Note: Depending on the selected motor design, the automatic encoder detection and calibration run (step 8) can be omitted.</p>
7	<p>Click on the <Next> button. The following window appears:</p>  <p>Check whether the encoder resolution was detected correctly and change the value in the upper selection menu if necessary. In BLDC motors, the encoder resolution cannot be detected automatically and therefore must be set by the user. Then select a parameter set in the lower selection menu if necessary.</p>

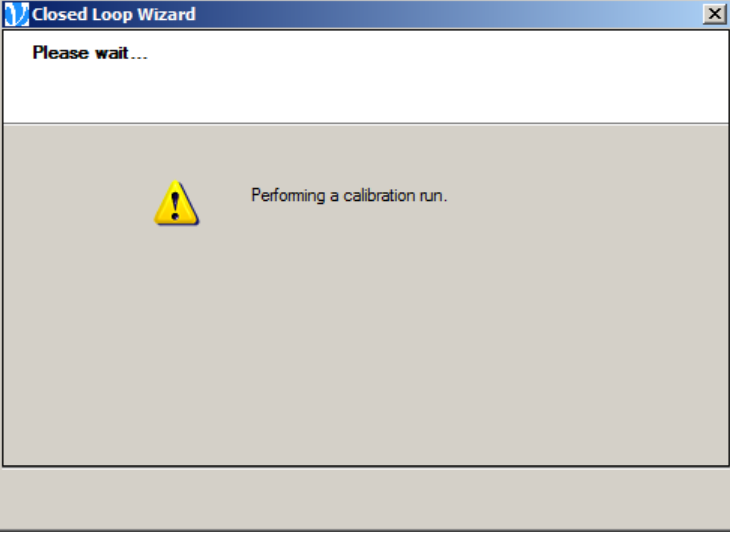
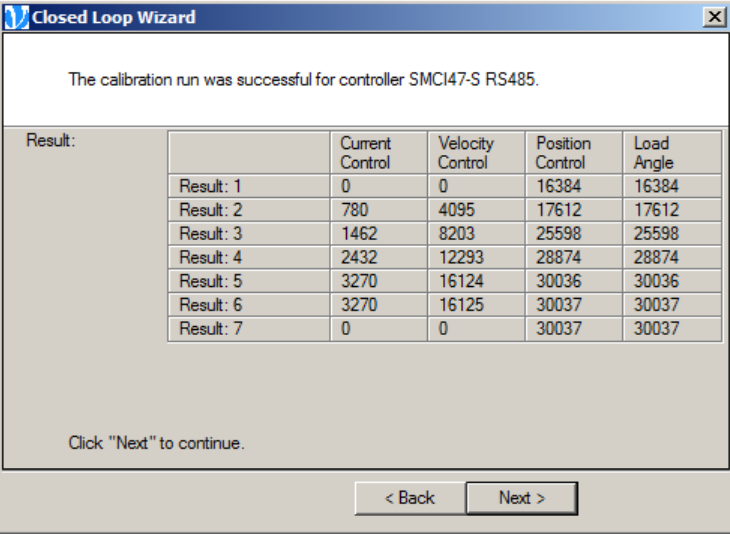
Step	Action
8	<p>Click on the <Next> button. A calibration run is then performed. The following window appears during the process:</p>  <p>The following window appears after the successful calibration run:</p>  <p>Check the measurement results of the calibration run.</p>

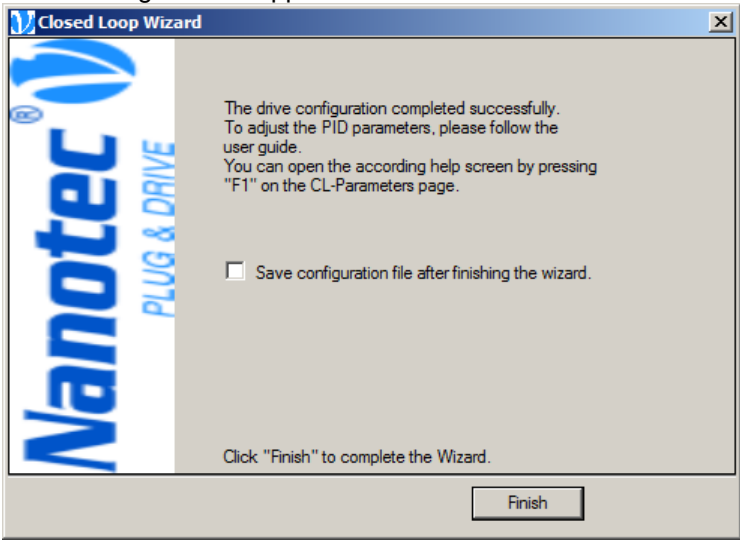
Step	Action
9	<p>Click on the <Next> button. The following window appears:</p>  <p>Activate the checkbox if the configuration file should be saved.</p>
10	Click on the <Finish> button to complete the Closed Loop Wizard.

Autotune Wizard

Using the <Autotuning-Wizard> button, start the autotune wizard that can be used to empirically determine suitable control parameters.

Please ensure that you have fully executed the closed loop wizard before starting the autotune wizard.

	<p>CAUTION!</p> <p>Motor haltingly makes several revolutions. Possible damage to the system in which the motor has been installed.</p> <ul style="list-style-type: none"> • Ensure that a motor is connected. • Check the interface parameters in the <Communication> tab!
-------------------------------------------------------------------------------------	-----------------------------------------------------------------------------------------------------------------------------------------------------------------------------------------------------------------------------------------------------------------------------------------------------------------

Proceed as follows:

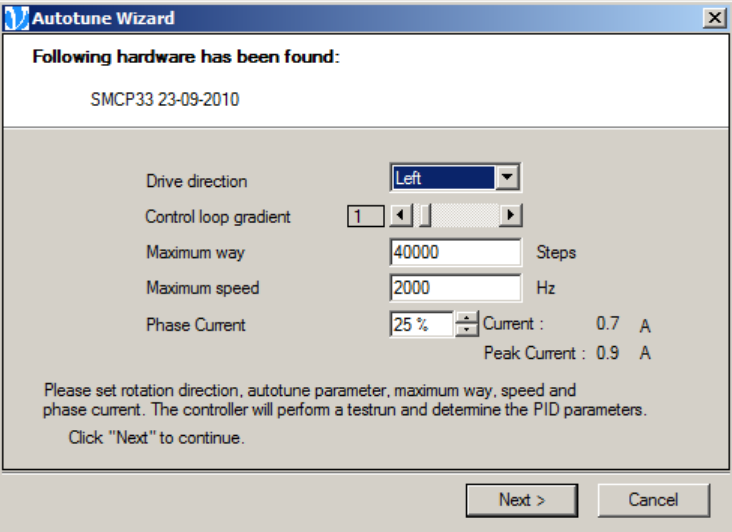

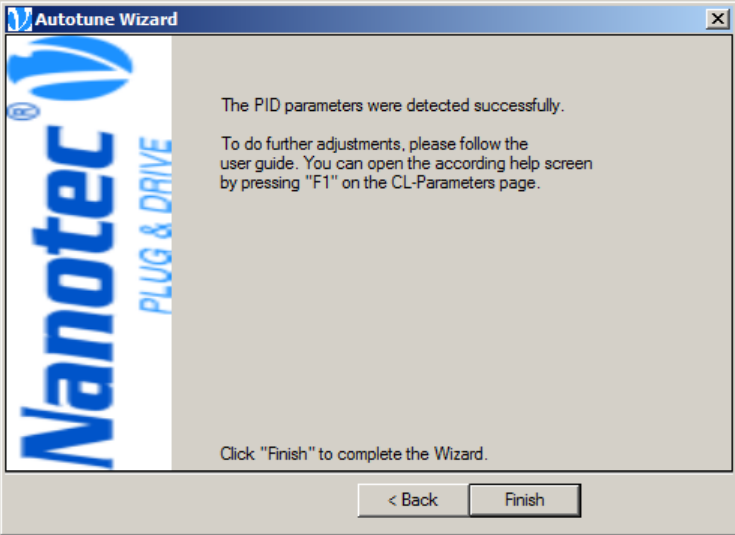
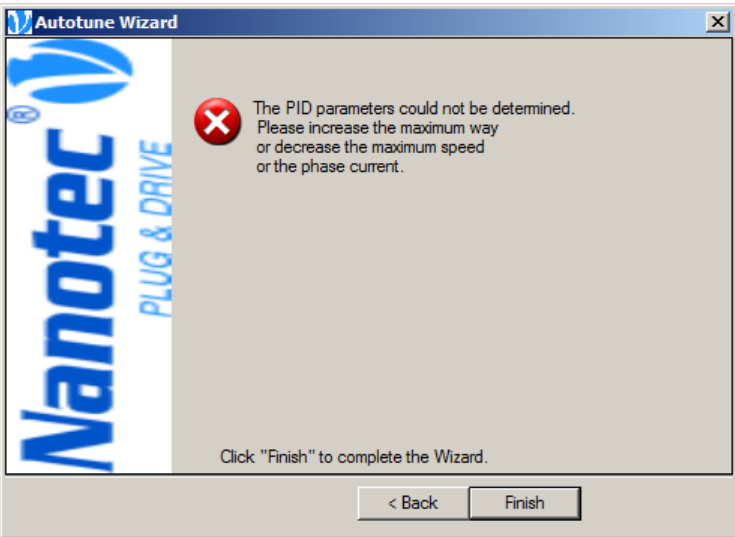
Step	Action
1	<p>Click on the <Autotuning - Wizard> button. The following window appears:</p> 
2	<p>Click on the <Next> button. The following window appears:</p> 
3	<p>Adjust the following parameters if necessary:</p> <ul style="list-style-type: none"> • Drive direction: direction of rotation in which the autotune run takes place. • Control loop gradient: proportional factor for sharpness of the controller in area 0.1 to 10. Value < 1: controller weaker Value = 1: controller neutral Value = >1: controller sharper • Maximum way: maximum distance that is covered during an autotuning run. • Maximum speed: speed to which the motor accelerates during an autotuning run. • Phase Current: current that is applied to the motor during the autotuning run.

Step	Action
4	<p>Click on the <Next> button. An autotuning run is performed. The following window appears after the procedure:</p>  <p>The following window appears after the autotuning run if applicable:</p>  <p>The specified maximum way may have been too short to reach the specified maximum speed. Try to increase the way or to reduce the speed or current.</p>
5	Click on the <Finish> button to complete the autotuning wizard.
6	Click on the <Save Data> button to save the determined parameters in the controller.

Quick CL Wizard

Like the "CL Wizard", the "Quick CL Wizard" determines the encoder offset, but it only requires a few steps of travel distance. For this reason, the CL mode can already be activated by selecting "Auto-Enable with Offset without index" without requiring a reference run after the motor controller is switched on and after the Quick CL Wizard is executed.

Proceed as follows:

Step	Action
1	Click on the <Quick CL Wizard> button. The following window appears: 
2	Click on the <Yes> button. The motor shaft moves back and forth slightly.
3	The following message appear after the encoder offset is determined: 

The encoder offset is only determined if the value is "0" before the quick test run. Otherwise, the shaft does not move and a value is not determined.

The encoder offset can be set manually via the Expert tab.

14 <Scope> tab

Function

In scope mode, important motor parameters can be displayed and recorded during a run. This is primarily used to check the set parameters or the commissioning of a drive.

Display

The scope mode settings are made in the <Scope> tab.

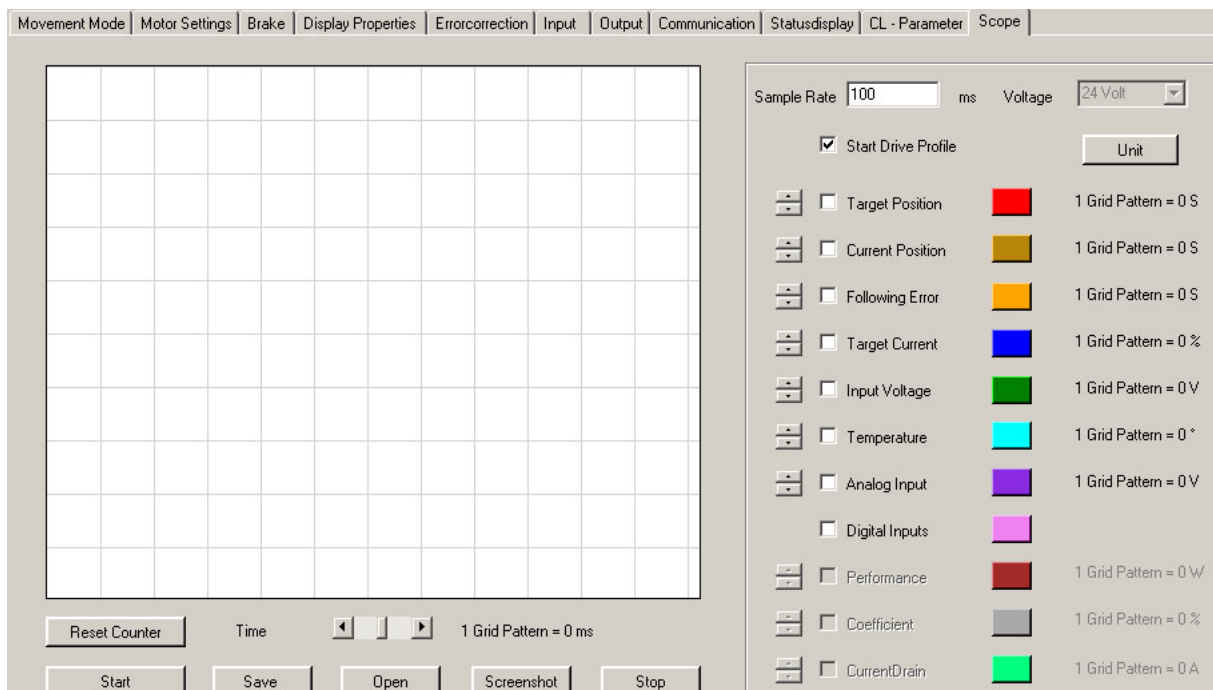

Selectable parameters

“Target position” and “Current position” parameters

The **target position** is the target value calculated by the ramp generator of the motor.

The **current position** is the position determined with the help of the motor encoder. In normal cases, the target and current positions should match. The current position is always 0 in a motor without encoder. If the target and current position deviate from one another, this may be due to various reasons:

- Step loss during the run: When the motor does not reach its target position during open loop operation, step losses have occurred. Possible countermeasures:
 - Select a flatter ramp
 - Select a lower speed
 - Increase motor current so that the motor has more strength

- Incorrect setting of the encoder: When the curves for setpoint and actual position are mirrored during a run, the rotation direction of the encoder is inverted (e.g. run of 400 steps, then setpoint position 400 and actual position -400).
Countermeasure: Reverse the rotation direction of the encoder in the <Motor Settings> tab.

CAUTION!

To have these settings accepted for closed loop operation, the motor must be disconnected from the power supply.

When the curves are identical in direction, but differ in gradient, then the resolution of the encoder is incorrect.

Counter measure: Adjust the encoder resolution in the <Motor Settings> tab.

Other parameters

Parameters	Description
Following error,	The following error indicates the difference between the target and actual position. If the following error exceeds the set value, the motor will output a position error. For the open loop mode, the limit value can be set in the <Errorcorrection> tab. For the closed loop mode, there are separate values for the speed mode and the positioning mode. They can be set in the <CL - Parameter> tab.
Target Current	The "Target Current" value specifies the set phase current in open loop mode. In closed loop mode, the current calculated by the motor is displayed.
Actual Voltage	Indicates the voltage applied to the motor.
Temperature	Indicates the temperature measured by the motor.
Analog input	Indicates the voltage at the analog input.
Digital Inputs	Sets the level of all digital inputs of the motor.

Parameters for the Closed Loop mode

Power	Indicates the power output by the motor.
Efficiency	Indicates the efficiency of the motor.
Current Drain	Indicates the current consumption of the motor.

Display of parameters

Activate/Deactivate

Activating the checkbox displays the progression of the respective parameter in the Scope mode.

Color

The color with which the parameter is displayed can be changed by clicking on the colored box.

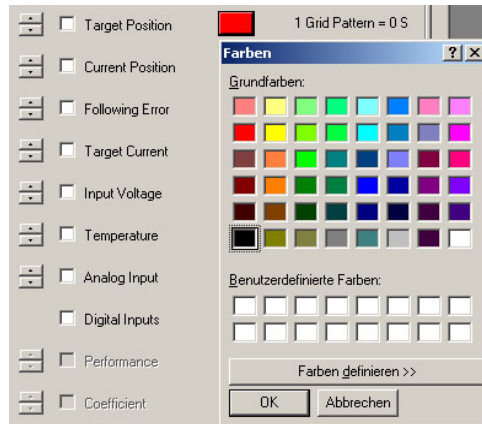

Scaling

The scaling of the parameter is specified under the <Unit> button and can be changed with the arrow keys (to the left of the checkboxes).

Clicking on the <Unit> button changes its labeling to <Value>. The current parameter values are then displayed instead of parameter scaling when the Scope mode is running.

The horizontal axis can be changed in the ms grid using the <Time> slider.

Adjustment parameters

The following settings can be made for the Scope mode:

Setting	Function
Sampling Rate	Setting of the sample rate in milliseconds.
Voltage	Voltage with which the motor is driven.
Start Drive Profile	When the checkbox is activated, the travel profile currently set in the controller starts at the same time as the scope mode.

Controlling the Scope mode

Reset Counter	Sets the travel profile to the zero position.
Start / Stop	Starts/stops the scope mode (travel profile 32).
Save	Saves recorded parameters.
Open	Opens recorded and saved parameters.
Screenshot	Creates a screenshot of the current display.

15 <Expert> tab

Note:

Settings in the <Expert> tab should only be changed by experienced users who are familiar with working with stepper motors, Nanotec controllers and the NanoPro software.

Display

Various expert settings can be made in the <Expert> tab.

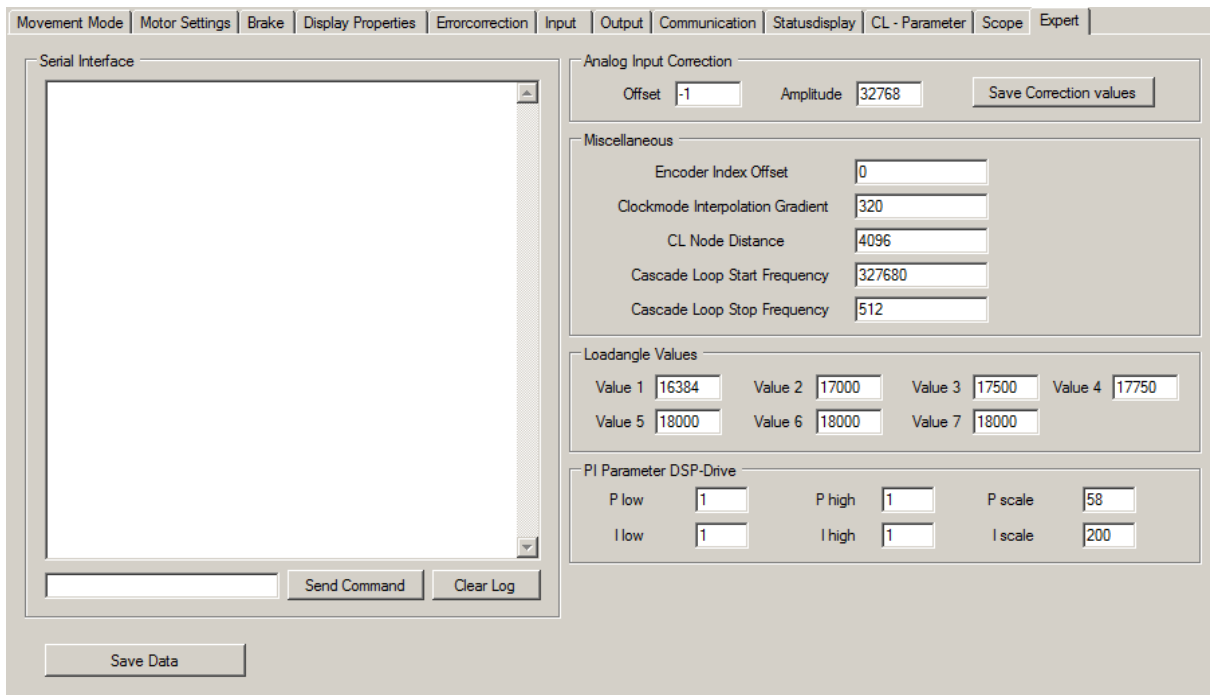

The screenshot shows the NanoPro software interface with the 'Expert' tab selected. The interface includes a menu bar at the top with options: Movement Mode, Motor Settings, Brake, Display Properties, Errorcorrection, Input, Output, Communication, Statusdisplay, CL - Parameter, Scope, and Expert. The main window is divided into several sections:

- Serial Interface:** A large empty text area for communication, with 'Send Command' and 'Clear Log' buttons below it.
- Analog Input Correction:** Fields for 'Offset' (value: -1) and 'Amplitude' (value: 32768), with a 'Save Correction values' button.
- Miscellaneous:** Fields for 'Encoder Index Offset' (0), 'Clockmode Interpolation Gradient' (320), 'CL Node Distance' (4096), 'Cascade Loop Start Frequency' (327680), and 'Cascade Loop Stop Frequency' (512).
- Loadangle Values:** Seven input fields for values: Value 1 (16384), Value 2 (17000), Value 3 (17500), Value 4 (17750), Value 5 (18000), Value 6 (18000), and Value 7 (18000).
- PI Parameter DSP-Drive:** Fields for 'P low' (1), 'P high' (1), 'P scale' (58), 'I low' (1), 'I high' (1), and 'I scale' (200).

A 'Save Data' button is located at the bottom left of the interface.

Parameter descriptions

The following parameters can be set:

Parameters	Function	Note
Serial interface		
Send Command	Direct access to the controller via the console.	For commands, see the programming manual.
Clear Log		
Analog Input Correction		
Offset	Offset of analog input.	Value range: -32768 to 32767 Default value: 0 Effective value range between -100 and +100. The parameter is not stored in the XML configuration file and is only transferred to the controller by clicking on the <Save Correction values> values button, but not when the <Save Data> or <Save Configuration to Drive> button.
Amplitude	Gain of analog input.	Value range: 0 to 65535 Default value: 32768 Effective value range between 32000 and 34000. The parameter is not stored in the XML configuration file and is only transferred to the controller by clicking on the <Save Correction values> values button, but not when the <Save Data> or <Save Configuration to Drive> button.
Miscellaneous		
Clockmode Interpolation Gradient	Specifies the maximum time in milliseconds after which an interpolated support threshold value is reached if a further clock signal does not take place before then.	Value range: 0 to 16383 Default value: 320
CL Node Distance	Distances of the individual load angles, where the value 8192 corresponds to 1000 rotations per minute.	Value range: 1 to 65535 Default value: <ul style="list-style-type: none"> • Stepper motors: 4096 • BLDC motors: differ by motor type.
Cascade Loop Start Frequency	Frequency above which the cascade loop is active.	Value range: 0 to 2147483647 Default value: 327680

Parameters	Function	Note
Cascade Loop Stop Frequency	Frequency up to which the cascade loop is active.	Value range: 0 to 2147483647. Default value: 512
load angle values		
Value 1 to 7	Lead values for the magnetic field.	Value range: -32768 to 32767 Default values: differ according to the motor type. The value $65536 = 2^{16}$ for the load angle value corresponds to 360° . These parameters are only transferred to the controller by clicking on the <Save load angle values and offset> button, but not when the <Save Data> or <Save Configuration to Drive> button is clicked.
Encoder Index Offset	Specifies the mechanical offset of the encoder to the rotor.	Value range: -32768 to 32767 Default value: 0 This parameter is only transferred to the controller by clicking on the <Save load angle values and offset> button, but not when the <Save Data> or <Save Configuration to Drive> button is clicked.
PI Parameter DSP-Drive (only with controllers with a dspDrive)		
P low	P component of the current controller at a standstill.	Value range: 0 to 1000 Default value: 1
P high	P component of the current controller during the run.	Value range: 0 to 1000 Default value: 1
P scale	Scaling factor for the speed-dependent adjustment of the P component of the current controller during the run.	Value range: 0 to 1000 Default value: 58 P component = P run + speed * P scaling
I low	I component of the current controller at a standstill.	Value range: 0 to 1000 Default value: 1
I high	I component of the current controller during the run.	Value range: 0 to 1000 Default value: 1
I scale	Scaling factor for the speed-dependent adjustment of the I component of the current controller during the run.	Value range: 0 to 1000 Default value: 200 I component = I run + speed * I scaling
Hall mode (only for BLDC drive)		

Parameters	Function	Note
Value 1 to 6	Positions of Hall sensors.	For a detailed explanation, see Hall Mode Command in the programming manual.

16 Operating multiple motors

Introduction

Up to 254 motors can be controlled in a network.

The motor address must be assigned in advance for each motor, see Section 11 "<Communication> tab".

New motors can be added in the "Motor" menu by clicking on the <Add Motor> button.

All the motors are displayed in the selection menu.

Unnecessary motors can be removed from the controller by clicking on the <Remove Motor> button.

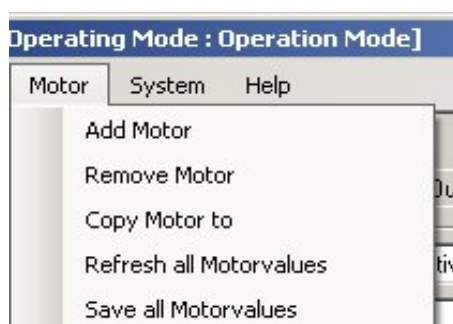

"Motor Address" menu

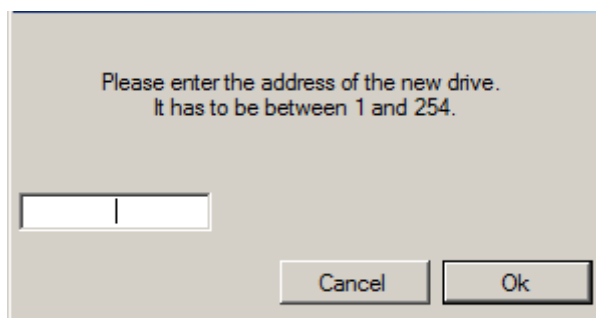

Procedure

Proceed as follows to add new motors:

Step	Action	Note
1	Select the "Add Motor" menu item in the "Motor" menu.	The "Motor address" menu opens.
2	Enter a motor address for the motor (number).	Number 1 to 254.
3	Click on the <OK> button.	The settings are saved.

Changing the motor address

The motor address may only be changed if exactly one motor has been connected. See Section 11 "<Communication> tab".

17 Troubleshooting

17.1 General information

Error messages

The motor monitors specific functions and outputs an error message if there is a malfunction.

Error messages are displayed in a pop-up window, e.g.:



Descriptions of possible error messages can be found in Section 17.2 "Error messages".

Troubleshooting procedure

Proceed with care during troubleshooting and error rectification to avoid damaging the motor.



Danger of electrical surges

An operating voltage of > 50 V (for SMCI12 a voltage of > 26 V, for SMCI36 a voltage of > 72 V) and incorrect connections can destroy the end stage.

Never disconnect the link when operating voltage is applied!

Never disconnect lines when live!

17.2 Error messages

Communication error

This message appears when data transmission to the controller is not possible:



The following causes may be responsible:

- The wrong COM port is set (see Section 11 "<Communication> tab").
- The communication cable is not connected or interrupted.
- A nonexistent motor number is set.
- The voltage supply to the motor is interrupted.

Controller is not ready

If inadmissible data is sent to the motor controller during the output of a travel profile, the following message appears:

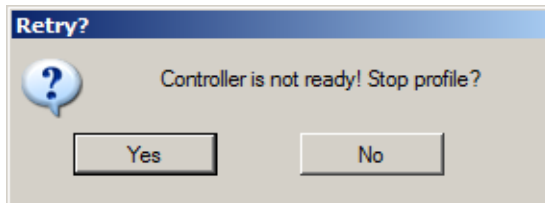

Pressing the <Yes> button stops the travel profile and the controller switches back to the "Ready" state. The data can then be resent to the controller.

Pressing the <No> button allows the travel profile to continue.

Position error

If a button is clicked while the motor is in error mode (position error or limit switch in normal operation), the following message is displayed.

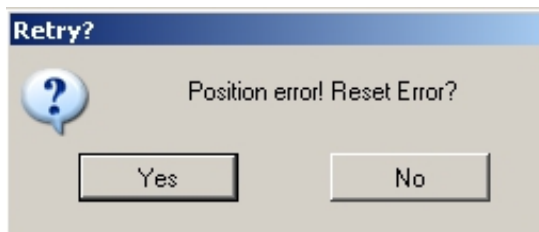

The error can be reset by pressing the <Yes> button.

Following error,

If a button is clicked while the motor is in error mode (following error), the following message is displayed.

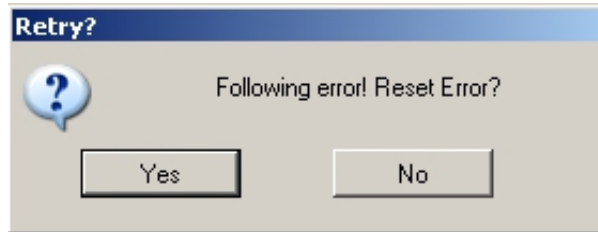

A following error occurs if the motor is in speed mode and either closed loop or error correction is activated and the actual value differs from the measured value.

The error can be reset by pressing the <Yes> button.

Clock frequency

If an attempt is made to communicate with the controller, while the motor is presently operated in the Clock Direction mode with a clock frequency of more than 65 kHz, then the following message appears:



Communication can only take place again if a clock frequency of less than 65 kHz is set.

Index

Absolute positioning mode	19	Expert tab.....	80
Actual Voltage	78	External reference run	13, 19, 32, 53
Analog input.....	78	Feed rate.....	47
Analog mode	35	Filter	52
Analogue positioning mode	37	Firmware update	10
Automatic Errorcorrection.....	49	Flag positioning mode.....	28
Autotune Wizard	73	Following error,	66, 67, 78
Baudrate	60	Frequency	
Brake	45	decrease.....	25
Brake ramp	21	increase.....	25
Break	21, 30	Gear reduction	47
Cascade controller,.....	68	Input Debounce Time	57
CL - Wizard.....	64	Inputs	51
CL Parameter	64	Installation.....	7
Clock Direction mode	32	Interface	60
Closed loop current control.....	11, 43, 64	Internal reference run	13, 19, 32, 53
Communication.....	60	Joystick mode	35
Correction run	49	Limit switch behavior.....	53
Counter		during normal operation	55
Read.....	18	during reference run.....	55
Reset.....	17	Type	55
Current Drain	78	Menu	
Current position	77	File.....	9
Delivery condition	18	Help	10
Digital Inputs	78	Language	9
Direction.....	21	Motor,	9, 84
Display Properties	45, 47	System	10
Distance.....	47	Minimal Speed	21
Drive Step Angle.....	41	Motor Settings.....	11, 12, 16, 17, 40, 44
Efficiency	78	Motor Type.....	40
Encoder	48, 50	Motor,	
Encoder direction of rotation.....	43	Add	9, 84
Encoder Position	62	Change Drive Address	60
End position tolerance	66	Check Drive Address	60
Error correction.....	48	Choose Drive Address	60
Error Display	62	Copy to	9
Error messages	85	Define Address.....	84

Read out values	9	Rotation Encoder Resolution	42
Remove.....	9	Sampling Rate	79
Save values	10	Save Configuration to Drive/Read Configuration from Drive	11
Search Drive Address	60	Save to	
Select	9	Drive	17
Network.....	84	reading out	17
Next Record.....	22	Scope mode.....	77
Online help	10	Screenshot.....	79
Operating modes	13	Search Controller	61
Absolute positioning mode.....	19	Send State Byte Automatically Upon End Of Record.....	42
Analog mode.....	35	Signal curves	
Analogue positioning mode	37	Clock Direction mode	34
Clock Direction mode.....	32	Flag positioning mode	31
Flag positioning mode.....	28	Relative/Absolute Position Mode	24
Joystick mode	35	Speed mode	27
Relative positioning mode.....	19	Speed.....	47
Speed mode.....	25	Speed mode.....	25
Torque mode.....	39	Start / Stop	79
Outputs	58	Start Drive Profile.....	79
Phase current	41	State Display	17, 57, 59, 62
at a standstill	42	Statusdisplay.....	62
Play (dead range)	52	Step mode.....	41
Polling	63	Stopping a record.....	17
Position.....	47	Swing Out Time	49
Position Demand	21	System requirements.....	7
Position error monitoring	67	Tabs	11
Position loop	66	Brake	45
Power.....	78	CL Parameter	64
Profile graph	17, 24	Communication	60
Programming language	63	Display Properties	45, 47
Quick Stop	17	Error correction.....	48
Ramp	21	Inputs.....	51
Ramp Type	23	Motor Settings	40, 45
Reference run	13, 19, 32, 53	Outputs.....	58
Relative positioning mode	19	Scope	77
Repetitions.....	22, 30	State	13
Reset Positions.....	79	Statusdisplay	62
Reverse Clearance.....	42	Target Current.....	78
Reverse direction.....	22	Target position	77
Rotation Encoder Monitoring	48, 49		

Target Speed.....	21	Update	10
Temperature	78	User defined inputs.....	55
Test Record	17	User defined outputs.....	58
Timeout.....	60	V Maximum	30
Tolerance Width	49	Velocity loop.....	65
Torque mode	39	Voltage.....	79
Travel profiles	15, 18	Voltage limit	51
Trigger on	29		