

Technical Manual



Plug & Drive Motors PD6-N8918

NANOTEC ELECTRONIC GmbH & Co. KG
Gewerbestraße 11
D-85652 Landsham near Munich, Germany

Tel. +49 (0)89-900 686-0
Fax +49 (0)89-900 686-50
info@nanotec.com

Editorial

© 2009

Nanotec[®] Electronic GmbH & Co. KG

Gewerbestraße 11

D-85652 Landsham / Pliening, Germany

Tel.: +49 (0)89-900 686-0

Fax: +49 (0)89-900 686-50

Internet: www.nanotec.de

All rights reserved!

MS-Windows 2000/XP/Vista are registered trademarks of Microsoft Corporation.

Version/Change overview

Version	Date	Changes
1.0	2009-05-27	New issue C+P
1.1	2009-11-16	Revision C+P

About this manual

Target group

This technical manual is aimed at designers and developers who need to operate a Nanotec[®] stepper motor without much experience in stepper motor technology.

Important information

This technical manual must be carefully read before installation and commissioning of the Plug & Drive Motor.



Nanotec[®] reserves the right to make technical alterations and further develop hardware and software in the interests of its customers to improve the function of this product without prior notice.

This manual has been written with due care. It is exclusively intended as a technical description of the product and as commissioning instructions. The warranty is exclusively for repair or replacement of defective equipment, according to our general terms and conditions, liability for subsequent damage or errors is excluded. Applicable standards and regulations must be complied with during installation of the device.

For criticisms, proposals and suggestions for improvement, please contact the above address or send an email to: info@nanotec.com

Additional manuals

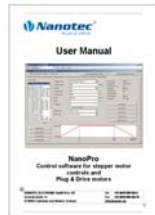
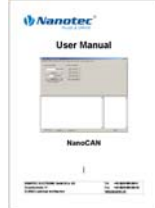
Please also note the following manuals from Nanotec:

<p>NanoPro User Manual</p>	<p>Configuration of controllers with the NanoPro software</p>	
<p>NanoCAN User Manual</p>	<p>Configuration of the CAN communication for CANopen-capable controllers with the NanoCAN software</p>	
<p>Nanotec CANopen reference</p>	<p>Detailed documentation of the CANopen functions</p>	
<p>Programming manual</p>	<p>Controller programming</p> <ul style="list-style-type: none"> • Command reference • NanoJ • COM interface 	

The manuals are available for download on www.nanotec.com.

Contents

1	Overview	5
2	Connection and commissioning	7
2.1	Connection diagram	7
2.2	Commissioning.....	9
3	Connections and circuits	11
3.1	Signal cable.....	11
3.2	Power cord	13
3.3	RS485 network/CANopen interface	14
4	Operating modes.....	18
5	Troubleshooting.....	20
6	Technical data	21
	Index.....	23

1 Overview

Introduction

The Plug & Drive Motor PD6-N8918 includes, in addition to the integrated power end stage, a complete, network-capable closed-loop speed and positioning control.

The PD6-N8918 not only significantly reduces development and installation outlay, but also space and component requirements. It also increases flexibility, system properties and the availability of a complete drive unit. Replacement of existing drive solutions is easy with the mechanical and electrical compatibility with standard motors.

Variants

The PD6-N8918 is available in the following variants that differ in holding torque, weight and length (see Section 6 "Technical data"):

- PD6-N8918S6404
- PD6-N8918M9504
- PD6-N8918L9504

Functions of the PD6-N8918

The Plug & Drive Motor PD6-N8918 has the following functions:

- Microstep 1/1 – 1/64 final output stage (0.014° step resolution)
- Closed-Loop current control (sinusoidal commutation via the encoder)
- Powerful DSP microprocessor for flexible I/O
- Integrated encoder for rotation monitoring and closed-loop current control
- RS485-/CANopen interface for parameterization and control (USB connection possible via converter cable ZK-RS485-USB)
- Network capability of up to 254 motors (RS485) or 127 motors (CANopen)
- Easy programming with the NANOPRO Windows software



Closed-Loop current control (sinusoidal commutation via the encoder)

In contrast to conventional stepper motor controls where only the motor is actuated or the position adjusted via the encoder, sinusoidal commutation controls the stator magnetic field as in a servomotor via the rotary encoder. The stepper motor acts in this operating mode as nothing more than a high pole servomotor, i.e. the classic stepper motor noises and resonances vanish. As the current is controlled, the motor can no longer lose any steps up to its maximum torque.

If the controller recognizes that the rotor is falling behind the stator field due to overload, adjustments are made with optimal field angle and increased current. In the opposite case, i.e. if the rotor is running forward due to the torque, the current is automatically reduced so that current consumption and heat development in the motor and controller are much lower compared to normal controlled operation.

dspDrive[®]

With dspDrive[®], the motor current is controlled directly by a digital signal processor. Unlike conventional ICs, which resolve the winding current measurement and the target current value with only 6 or 8 bit, the new dspDrive[®] performs the entire control with a resolution of 12 bit. The parameters of the PI current controller can be adjusted to the motor and by the user as a function of the rpm.

This has the following application advantages:

- Very smooth, low-resonance operation with a sinusoidal current in the windings.
- Very good step angle accuracy and synchronisation, even in open-loop operation.
- Three-phase stepper motors and BLDC motors can be controlled as well.

NanoJ

With the integrated NanoJ programming language based on the Java standard, complete sequencing programs can be implemented that can be run autonomously without a superordinate controller.

The programs can be created, compiled directly and written to the controller with the free NanoJEasy editor.

You will find all further information about this topic in the Programming manual.

Activation via CANopen

It is possible to include the stepper motor control in a CANopen environment with the PD6-N8918. The connection can be established either via 2 wires of the I/O connection cable or in a customer-specific version also via an M12 connector (5-pole).

You will find all further information about this topic in the CANopen reference and the NanoCAN user manual.

In addition, the Plug & Drive Motor via CANopen has another safety function: Even when the voltage supply of the PD6-N8918 is interrupted, the processor continues to be supplied with power via the communication line and the position data cannot be lost so that the machine does not need to be referenced after being switched on.

Settings

The operating behavior of the motor can be set and optimized according to individual requirements by setting the motor-related parameters. The parameters can be set using the NANOPRO software and significantly reduce commissioning time.

You will find all further information about this topic in the NanoPro user manual.

Speed control

Even if stepper motors do not lose steps during normal operation, the integrated speed control provides additional security in all operating modes, e.g. against motor stalling or other external sources of error. The monitoring function detects a stalled motor or step loss after a tenth step at the most (for 1.8° stepper motors with 500 pulses/revolution).

Automatic error correction is possible after the drive profile is ended or during the drive.

2 Connection and commissioning

2.1 Connection diagram

Introduction

To operate the Plug & Drive Motor, you must implement the wiring according to the following connection diagram.

Connection diagram PD6-N8918

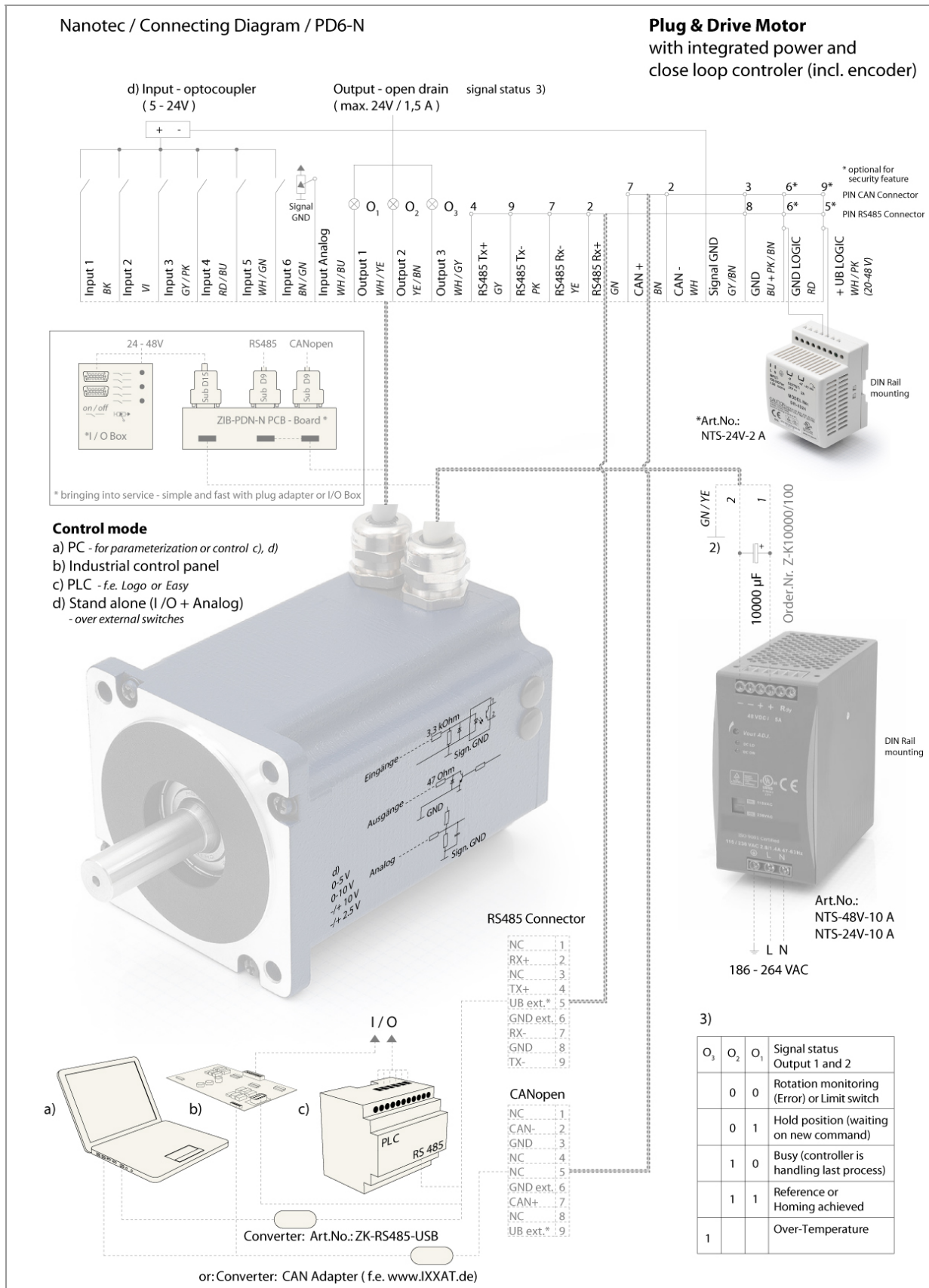

2.2 Commissioning

Provisions

The connection and commissioning of the PD6-N8918 Plug & Drive Motor are described below.

The main "First steps" are described here to work as fast as possible with the PD6-N8918 if you want to work with the NANOPRO software from a PC. You will find more detailed information in the separate NANOPRO manual.

If you want to work at a later time with a PLC or your own program, you will find the necessary information in the separate "Command Reference".

Familiarize yourself with the PD6-N8918 Plug & Drive Motor and the relevant NANOPRO control software before configuring the Plug & Drive Motor for your application.

Note:

For the operation and configuration of the Plug & Drive motors with a CANopen interface, you require the CANopen firmware and the NanoCAN software, which you can download from the Nanotec website.

Procedure

Proceed as follows to commission the Plug & Drive Motor:

Step	Action	Note
1	Install the NANOPRO driver software on your PC. See the separate manual on NANOPRO as well.	Download from www.nanotec.com/downloads .
2	Connect the Plug & Drive Motor according to the connection diagram. For easier commissioning the ZIB-PD6-N terminal strip that already integrates the SubD connections for RS485 and CANopen can be used.	Connection diagram, see Section 2.1. Detailed information on connections can be found in Chapter 3 „Connections and circuits“.
3	Apply the operating voltage (24 V DC ... 48 V DC).	The green LED lights up.
4	Connect the Plug & Drive Motor with your PC. Use the converter cable ZK-RS485-USB for connection to the USB interface. Connection via the RS232 interface is not possible.	Order number: • ZK-RS485-USB (download the necessary driver from www.nanotec.com under the menu item Accessories/Converter)
5	Start the NANOPRO software.	The NANOPRO main menu appears.

Step	Action	Note
6	Select the "Communication" tab. 	
7	In the field "Port", select the COM port to which the PD6-N8918 is connected. 	The number of the COM port to which the Plug & Drive Motor is connected can be found in the device manager of your Windows PC (System Supervision/ System/ Hardware).
8	Select the entry "115200 bps" in the selection field "Baudrate".	
9	Select the "Movement Mode" tab. 	
10	Click on the <Test Record> button to carry out the pre-set travel profile. 	The connected motor operates with the pre-set travel profile (default travel profile after new installation).
11	You can now enter your required settings. For instance, you can enter a new travel profile.	See the separate manual on NANOPRO as well.

3 Connections and circuits

3.1 Signal cable

Introduction

An overview of the assignments can be found in the connection diagram in Section 2.1). This section looks in detail at the assignment, functions and circuits of the signal cable.

Pin assignment

Name	Wire color
Input 1	BK
Input 2	VT
Input 3	GY/PK
Input 4	RD/BU
Input 5	WH/GN
Input 6	BN/GN
Analogue input	WH/BU
Output 1	WH/YE
Output 2	YE/BN
Output 3	WH/GY
RS485 Tx +	GY
RS485 Tx –	PK
RS485 Rx –	YE
RS485 Rx +	GN
CAN +	BN
CAN –	WH
Signal GND (Com)	GY/BN
GND	BU/PK-BN
GND Logic	RD
Vcc Logic	WH/PK

Input circuits

All inputs (apart from the "Analogue In" input) are electrically isolated by optocouplers from the voltage supply of the PD6-N8918 and designed for 5-24 V input signals at an input current of 8 mA.

The digital inputs 1 to 6 can be configured with the aid of the software NANOPRO for "active-high" or "active-low". In addition, these can be freely programmed there, e.g. as limit switch, enable, etc.

Note:

The voltage should drop below 2 V for safe switching off and be at least 4.5 V for safe switching on.

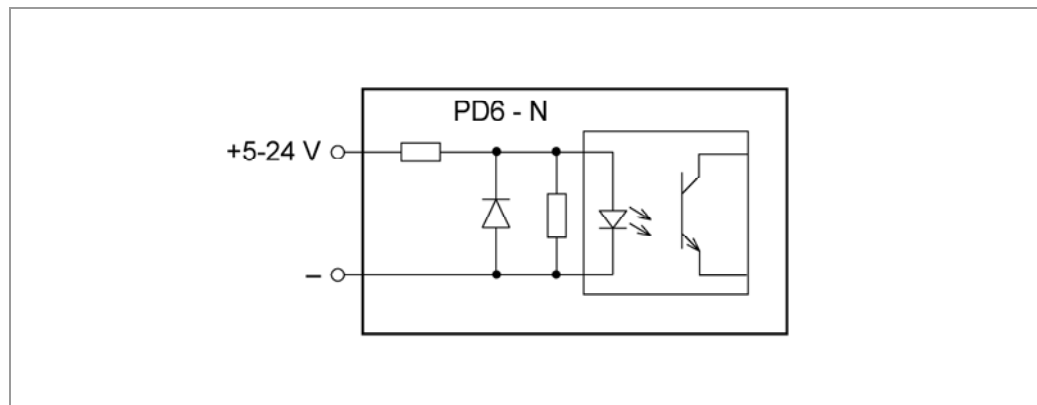

Output circuits

The outputs are MosFET outputs in an Open-Drain circuit (0 switching, max. 24 V/1.5 A). An LED can be integrated to test the output. The LED lights up when the output is active.

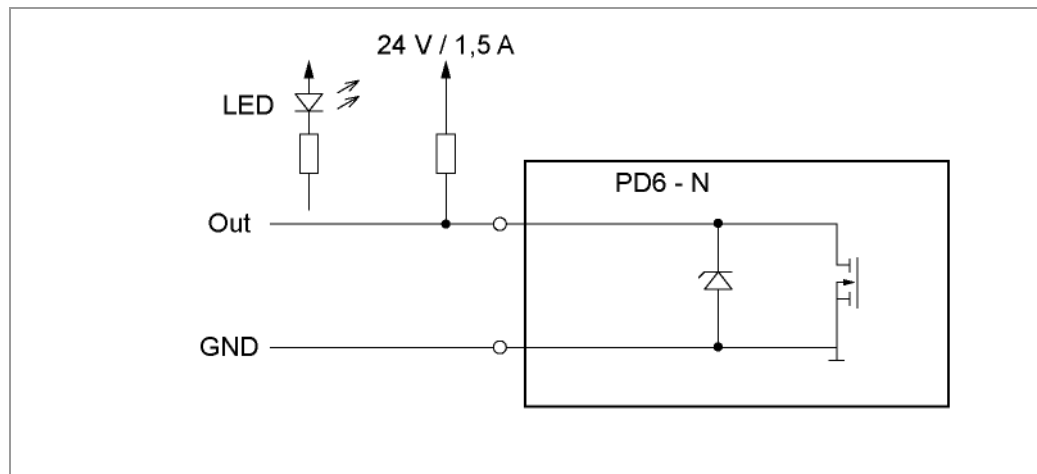

3.2 Power cord

Permissible operating voltage

The permissible operating voltage of the Plug & Drive Motor PD6-N8918 lies within the range +24 to +48 V DC and must not exceed 50 V or undershoot 21 V.

A charging condenser with minimum 4700 μF (10000 μF) must be provided for the operating voltage to prevent exceeding the permissible operating voltage (e.g. during braking).

	<p>Danger of electrical surges</p> <p>Connect charging condenser with minimum 4700 μF!</p> <p>An operating voltage > 50 V will destroy the output stage!</p> <p>Mixing up the connections can destroy the output stage!</p> <p>Never disconnect the link when operating voltage is applied!</p> <p>Never disconnect lines when live!</p>
---	---

Voltage supply connection diagram

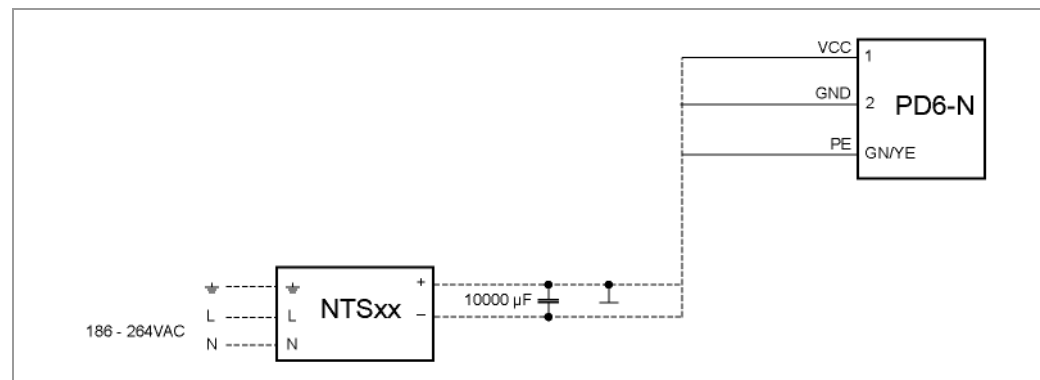

Note:
Complete connection diagram - see Section 2.1.

Pin assignment

Name	Wire number
Vcc	1
GND	2
PE	GN/YE

Accessories for voltage supply

Appropriate power packs and charging condensers are available as accessories:

Name	Order number
Power pack	NTS-xxV-xA
Charging condenser	Z-K4700 or Z-K10000

Note:
Further information about accessories can be found on the Nanotec website:
www.nanotec.com

3.3 RS485 network/CANopen interface

RS485 network

Up to 254 (RS485) or 127 (CANopen) Plug & Drive Motors can be actuated in a network from a PC or a PLC control.

These network connections are set up via the RS485/CANopen interface.

If you use the Plug & Drive Motor with CANopen, you can use the additional safety function of the separate logic supply: Even when the voltage supply of the PD6-N8918 is interrupted, the processor continues to be supplied with power via the communication line and the position data cannot be lost so that the machine does not need to be referenced after being switched on.

You will find all further information about this topic in the CANopen reference and the NanoCAN user manual.

Two-wire operation

To enable RS-485 two-wire transmission capability, all bus stations must have a direction control.

An "intelligent" converter enables two-wire operation of the PD6-N8918 as it automatically switches to transmit operation when receiving a start bit at the RS-232 interface and returns to reception standby at the end of the stop bit. This solution does not require software support.

We can recommend the ICP-7520 converter, for example, that is available from Schuricht.

Talk to our Technical Hotline if you require support for this.

CANopen

With the PD6-N8918 it is also possible to control the motor via CANopen.

You will find all further information about this topic in the CANopen reference and the NanoCAN user manual.

Circuit diagram RS485 network

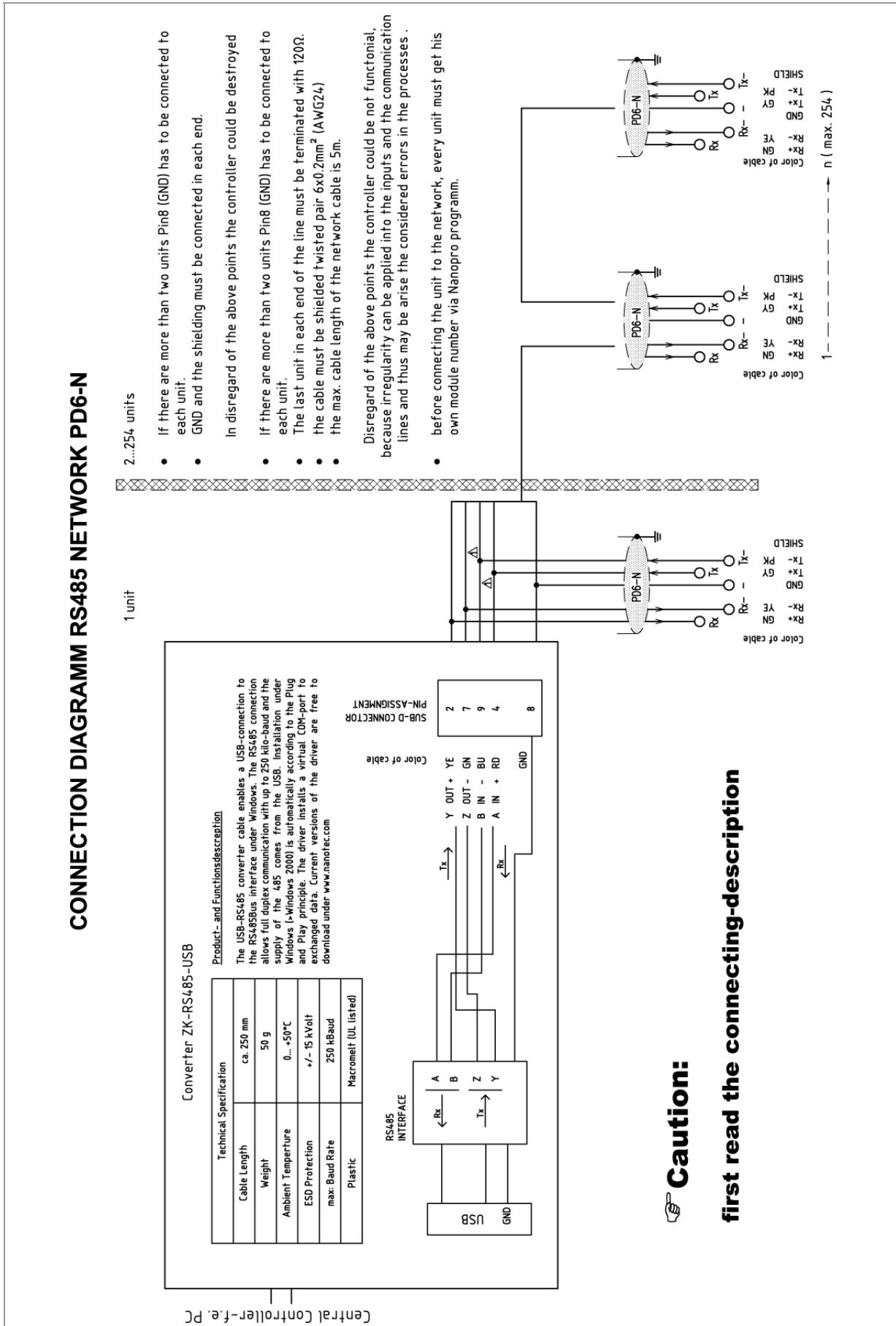

Setting the RS485 module address

Hardware setting

The RS485 module address can be set by hardware via two HEX coded switches on the printed circuit board.

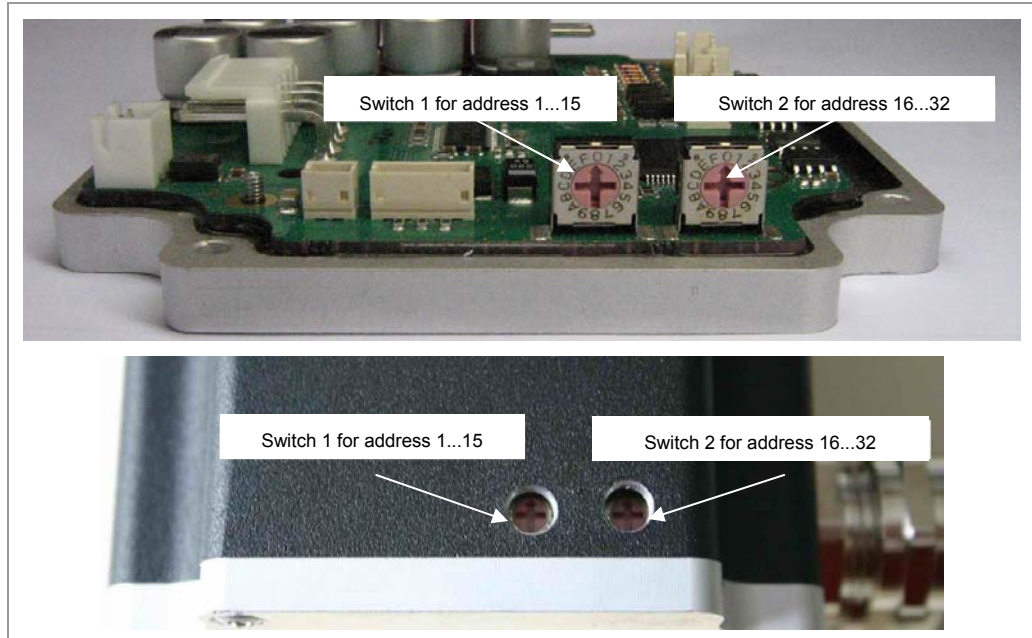

The 1st digit is set with switch 1 (left), the 16th digit of the address is set with switch 2 (right).

Module address	Switch 1 (left)	Switch 2 (right)
Software setting	0	0
1	1	0
2	2	0
...
15	F	0
16	0	1
17	1	1
...
32	0	2
...
64	0	3
...
80	0	5
...
96	0	6
...
112	0	7
...
255	F	F

Max. 255 addresses can be set which can, however, only be used to the full extent via CANopen as the maximum number of stations in an RS485 network is limited to 32.

When the power supply is applied, the controller checks which address is set with the 2 hardware switches. This hardware address is then adopted. After the address is changed, the power supply must be briefly switched off and on again.

Software setting

In the delivery condition, the two switches are set to 0. With a firmware status more recent than 04.12.2008 it is possible to set the address per software in this setting. See the separate manual on NANOPRO as well.

4 Operating modes

Introduction

The Plug & Drive Motor can be operated with a total of 14 different operating modes. Due to the great capacity and functions available, they offer designers and developers a rapid and simple method of resolving numerous drive requirements with less programming effort.

Select the required operating mode for your stepper motor application and configure the controller according to your requirements.

You will find more detailed information in the NANOPRO user manual.

Overview of operating modes and their areas of application

Operation Type	Application
Relative	Use this mode when you wish to travel to a specific position. The motor travels according to a specified drive profile from a Position A to a Position B.
Absolute	
Internal reference run	During the internal reference run, the motor travels to an internal reference point at the set minimum speed.
External reference run	During an external reference run, the motor travels to a switch connected to the reference input.
Speed mode	Use this mode when you wish to travel with a specific speed (e.g. a conveyor belt or pump speed). In the speed mode, the motor accelerates with a specified ramp from the starting speed (start frequency "V Start") to the specified maximum speed (maximum frequency "V Normal"). Several inputs enable the speed to be changed on-the-fly to different speeds.
Flag Position mode	The flag positioning mode offers a combination of the speed and positioning modes. The motor is initially operated in speed mode; when a trigger point is reached, it changes to the positioning mode and the specified setpoint position (relative to the trigger position) is approached. This operating mode is used for labeling, for example: the motor first travels with the set ramp to the synchronous speed of the conveyed goods. When the labels are detected, the preset distance (position) is traveled to apply the labels.
Clock direction mode, left	Use this mode when you wish to operate the motor with a superordinate controller (e.g. CNC controller). In the clock direction mode, the motor is operated via two inputs with a clock and a direction signal from a superordinate positioning control (indexer). Depending on the mode selected (Int. Ref. / Ext. Ref.) the internal and external reference runs are supported.
Clock direction mode, right	
Clock direction mode, Int. Ref.	
Clock direction mode, Ext. Ref.	

Operation Type	Application
Analogue and Joystick mode	<p>The motor is controlled in this operating mode simply with a potentiometer or a joystick (–10 V to +10 V). Use this mode if you want to use the motor in a simple application:</p> <ul style="list-style-type: none"> • Setting a specific speed, e.g. via an external potentiometer, • Travelling synchronously with a superordinate controller with analogue output (–10 V to +10 V).
Analogue Position mode	<p>Use this mode when you wish to travel to a specific position. The voltage level on the analogue input is proportional to the required position, thus enabling servo behavior.</p>
Torque mode	<p>Use this mode when you require a specific output torque independent of the speed as is the case in typical winding and unwinding applications. The maximum torque is specified via the analogue input.</p>

Selecting the operating mode in NANOPRO

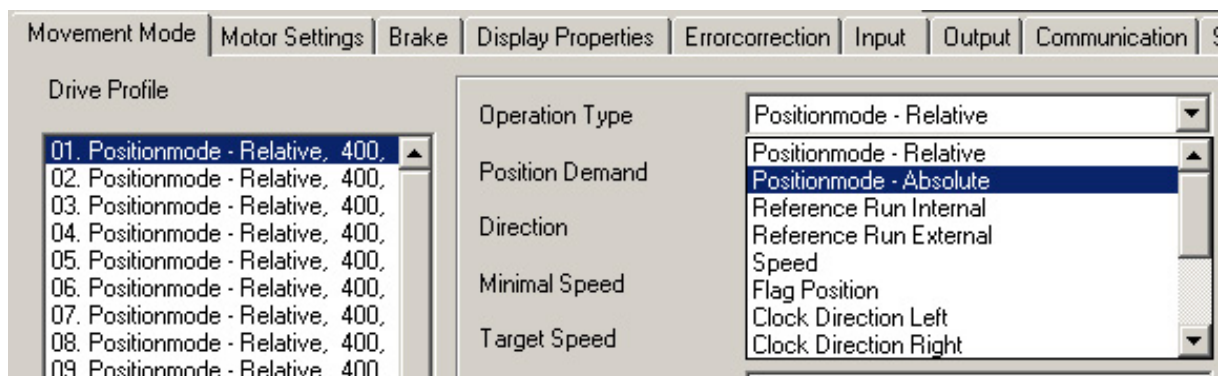

5 Troubleshooting

Troubleshooting procedure

Proceed with care during troubleshooting and error rectification to avoid damaging the Plug & Drive Motor.

	<p>Danger of electrical surges</p> <p>An operating voltage > 50 V and incorrect connections can destroy the end stage. Never disconnect the link when operating voltage is applied! Never disconnect lines when live!</p>
---	---

Possible error

Error	Possible cause	Rectification
Plug & Drive Motor is not ready	Data transfer to PD6-N8918 is not possible (communication error): Incorrect COM port selected.	In the "Communication" tab, select the PC port to which you have connected the PD6-N8918 (e.g. "COM-1"). The port used can be found in the device manager of your PC.
	Communication cable not connected or interrupted (incorrect RS485 converter used).	Function is not guaranteed with third-party 4-wire cables and 2-wire Nanotec converters do not function. Use the recommended RS485 converter from Nanotec: <ul style="list-style-type: none"> Order number: ZK-RS485-USB
	A non-existent motor number (module number) is set.	Set the correct module address. See separate manual on NANOPRO.
	The voltage supply to the PD6-N8918 is interrupted.	Check voltage supply, switch on if necessary.
	Another open program is blocking the COM port to which the PD6-N8918 is connected.	Close down other programs on your PC.
	Inadmissible data was sent to the Plug & Drive Motor during the output of a travel profile.	Click on the <Yes> button to stop the travel profile. The PD6-N8918 switches to the "Ready" status. The data can then be resent to the Plug & Drive Motor.
Transmission error	The data transfer to the PD6-N8918 is disturbed (transmitter or receiver are disturbed).	Check the possible causes for the transmission error and rectify the cause of the error.
Position error	The motor cannot reach the position or the limit switch was overrun.	Click the <Yes> button in the error message: the error is reset.
Red LED on the PD6-N8918 lit up.	Overtemperature of power electronics > 75 °C	Switch off Plug & Drive Motor and allow to cool. The error is reset when the PD6-N8918 is disconnected from the power supply unit.
	Undervoltage	Check voltage supply.

6 Technical data

Electrical connections

Operating voltage U_b	DC 24 V to 48V $\pm 4\%$
Max. phase current	Adjustable up to max. 12 A/phase Continuous current 7.5 A/phase
Current drop	Adjustable 0 to 80% of phase current
Interfaces	RS-485 (4-wire) <ul style="list-style-type: none"> • 115200 Baud (adjustable) • 1 Startbit, 8 Databits, 1 Stopbit • No parity CAN bus (CANopen) <ul style="list-style-type: none"> • Extended functionality • Separate circuit for supply and processor • Closed-Loop capable
Type of connection	PG gland, cable length = 2 m

Motor parameters

Step resolution	Full step Half step Quarter step Fifth step Eighth step Tenth step 16th step 32th step 64th step Adaptive microstep (1/128)
Step angle	1.8°
Operating modes	Position Speed Flag position Clock direction Analogue Joystick
Step frequency	0 to 50 kHz in clock direction mode 0 to 25 kHz in all other modes
Position monitoring	Automatic error correction up to 0.18° (depending on encoder resolution)

Inputs and outputs

Inputs	6 optocouplers, 5 – 24 V <ul style="list-style-type: none"> • Safe switch off: max. 2 V • Safe switch on: min. 4.5 V Signal delay time: <ul style="list-style-type: none"> • Inputs 1 to 5: 120 µs • Input 6: 10 µs
Outputs	3 MosFET outputs <ul style="list-style-type: none"> • Open-Drain (0 switching, max. 24 V/1.5 A) • Signal delay time: Output 1/2: ≈ 12 µs (at 10 kΩ-Pull-Up on 24 V)

Protective circuits

Overvoltage and undervoltage	Protective circuit for voltages > 50 V or < 21 V
Max. heatsink temperature	Approx. 67 °C External ventilation may be required in full step operation, depending on the switch-on duration, current drop set and external cooling area.
Max. ambient temperature	0 to 40 °C

Dimensions PD6-N8918

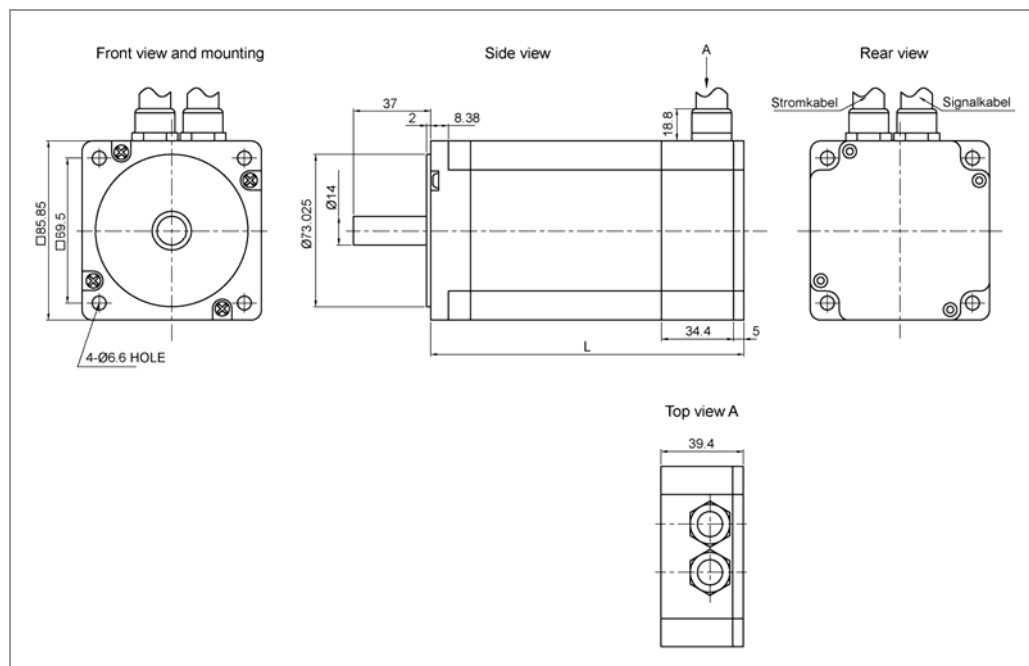

A complete set of datasheets is available for downloading at www.nanotec.com.

Variants

Variants	Holding torque (Nm)	Weight (kg)	Length "L" (mm)
PD6-N8918S6404	3.2	1.7	89
PD6-N8918M9504	5.94	3.4	120
PD6-N8918L9504	9.33	3.95	150

Index

A

Accessories for voltage supply 13

C

CanOpen 6, 14

Closed-Loop current control 5

Commissioning 9

Connection diagram 8

D

dspDrive 6

E

External reference run 18

F

Functions 5

I

Input circuits 12

Inputs and outputs 11

Internal reference run 18

N

NanoJ 6

O

Operating modes 18

Operating voltage 13

Output circuits 12

P

Pin assignment

 Power cord 13

 Signal cable 11

Power cord 13

R

Reference run 18

RS485 network 14

S

Signal cable 11

T

Two-wire operation 14

V

Variants 5, 23

Voltage supply 13