

# Technical Manual

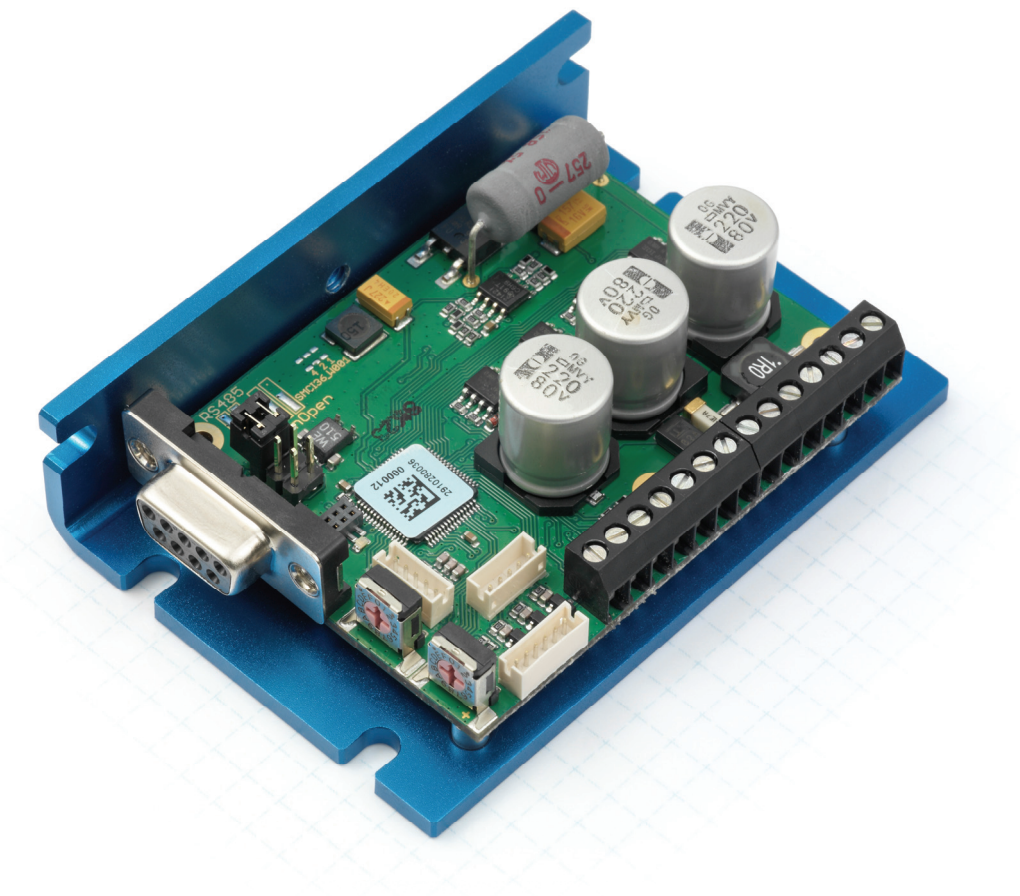

## Controller for stepper and BLDC motors **SMC136**

NANOTEC ELECTRONIC GmbH & Co. KG  
Kapellenstraße 6  
D-85622 Feldkirchen b. Munich, Germany

Tel. +49 (0)89-900 686-0  
Fax +49 (0)89-900 686-50  
[info@nanotec.com](mailto:info@nanotec.com)

## Editorial

© 2011

**Nanotec<sup>®</sup> Electronic GmbH & Co. KG**

Kapellenstraße 6

D-85622 Feldkirchen b. Munich, Germany

Tel.: +49 (0)89-900 686-0

Fax: +49 (0)89-900 686-50

Internet: [www.nanotec.com](http://www.nanotec.com)

All rights reserved!

MS-Windows 2000/XP/Vista/7 are registered trademarks of the Microsoft Corporation.

### Translation of the original operation manual

#### Version/Change overview

Version	Date	Changes
1.0	02/11/2011	New document C+P
1.1	11/03/2011	Revision C+P

## About this manual

### Target group

This technical manual is intended for designers and developers who lack extensive experience with stepper motor technology but who need to commission a Nanotec<sup>®</sup> motor.

### Important information

This technical manual must be carefully read before installing and commissioning the controller.





In the interests of its customers and to improve the function of this product, Nanotec<sup>®</sup> reserves the right to make technical alterations and further develop hardware and software without prior notice.

This manual was created with due care. It is exclusively intended as a technical description of the product and as commissioning instructions. The warranty is exclusively for repair or replacement of defective equipment, according to our general terms and conditions; liability for subsequent damage or errors is excluded. Applicable standards and regulations must be complied with during installation of the device.

For criticisms, proposals and suggestions for improvement, please contact the above address or send an email to: [info@nanotec.com](mailto:info@nanotec.com)

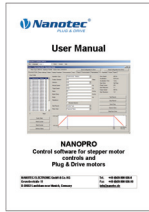
### Additional manuals

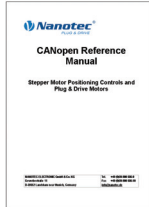
Please also note the following manuals from Nanotec:

<b>NanoPro User Manual</b>	Configuration of controllers with the NanoPro software	
<b>NanoCAN User Manual</b>	Configuration of the CAN communication for CANopen-capable controllers with the NanoCAN software	
<b>Nanotec CANopen reference</b>	Comprehensive documentation of the CANopen functions	
<b>Programming manual</b>	Controller programming <ul style="list-style-type: none"> <li>• Command Reference</li> <li>• NanoJ</li> <li>• COM port</li> </ul>	

The manuals are available for downloading at [www.nanotec.com](http://www.nanotec.com).

# Contents

<b>1</b>	<b>Overview .....</b>	<b>5</b>
<b>2</b>	<b>Connecting and commissioning .....</b>	<b>7</b>
2.1	Overview .....	7
2.2	Stepper motor .....	8
2.3	BLDC motor .....	9
2.4	Commissioning.....	10
<b>3</b>	<b>Connections and wiring .....</b>	<b>13</b>
3.1	Hall sensor: Connector X1 .....	13
3.2	Inputs and outputs: Connectors X4 and X5 .....	13
3.3	Encoder connection: Connector X2 .....	15
3.4	Motor and power supply connection: Connector X3 .....	16
3.4.1	Pin assignment.....	16
3.4.2	Stepper motor connection.....	16
3.4.3	BLDC motor connection.....	16
3.4.4	Power supply connection .....	17
3.5	RS485 network/CANopen: Connector X14.....	18
<b>4</b>	<b>Operating modes.....</b>	<b>23</b>
4.1	Serial operating modes .....	23
4.2	CANopen operating modes.....	25
<b>5</b>	<b>Troubleshooting.....</b>	<b>26</b>
<b>6</b>	<b>Technical data .....</b>	<b>28</b>
	Index.....	30

# 1 Overview

## Introduction

Motor controller SMCI36 is an extremely compact and cost-effective constant current final output stage with integrated Closed-Loop current control.

Due to its powerful performance and functional variety, it offers designers and developers a rapid and simple method of resolving numerous drive requirements with less programming effort.

It is used for controlling standard stepper motors (including with attached encoders) or motors with an integrated encoder. BLDC motors are also supported.

The SMCI36 is ideal for device installation due to its open, economical design. For machine integration, we recommend the closed controllers SMCI33 and SMCI47-S-2, which can also process 24 V signals and are built on the same software basis.

## SMCI36 functions

The SMCI36 controller features the following functions:

- 12-72 V supply voltage, rated current 6 A rms, max. phase current 9 A rms.
- Microstep -1/1 – 1/64 final output stage (step resolution of up to 0.014° in motor with a step angle of 0.9° in 1/64 step mode)
- Closed-Loop current control (sinusoidal commutation via the encoder)
- Sinusoidal commutation for BLDC motors with hall sensors for better running smoothness and higher speed ranges
- RS485/CANopen port for parameterization and control
- Network capability with up to 254 motors (RS485) or 127 motors (CANopen)
- Microstep emulation in full step operation for smoother running
- Powerful DSP microprocessor for flexible I/O
- Sequence programs with NanoJ
- Easy configuration with the NanoPro or NanoCAN Windows software



Closed-Loop current control (sinusoidal commutation via the encoder)

In contrast to conventional controllers which only actuate the motor or adjust the position via the encoder, sinusoidal commutation controls the stator magnetic field via the rotary encoder as in a servomotor. The stepper motor acts in this operating mode as nothing more than a high pole servomotor, i.e. the classic stepper motor noises and resonances vanish. Because the current is controlled, the motor can no longer lose any steps up to its maximum torque.

If the controller recognizes that the rotor is falling behind the stator field due to overload, adjustments are made with optimal field angle and increased current. In the opposite case, i.e. if the rotor is running forward due to the torque, the current is automatically reduced so that current consumption and heat development in the motor and controller are much lower compared to normal controlled operation.

### *dspDrive*<sup>®</sup>

With dspDrive<sup>®</sup>, the motor current is controlled directly by a digital signal processor. Unlike conventional ICs, which resolve the winding current measurement and the target current value with only 6 or 8 bits, the new dspDrive<sup>®</sup> performs the entire control with a resolution of 12 bits. The parameters of the PI current controller can be adjusted to the motor and its target speed.

This has the following application advantages:

- Very smooth, low-resonance operation with a sinusoidal current in the windings, even at low speeds.
- Very good step angle accuracy and synchronization, even in open-loop operation.
- BLDC motors can be controlled as well.

### *NanoJ*

The integrated programming language NanoJ, based on the Java standard, means complete application programs can be realized on the drivers that can be executed independently without a higher-order controller.

The programs can be created, compiled directly and written to the controller with the free NanoJEasy editor.

More detailed information can be found in the separate programming manual.

## Activation via CANopen

### **CANopen**

It is possible to include the stepper motor controller in a CANopen environment with the SMCI36.

More detailed information on this can be found in the CANopen reference and in the NanoCAN user manual.

## Presettings

When the SMCI36 is delivered, it is preconfigured to relative positioning mode.

The step mode can only be changed via software. It is preset to the half step setting. Due to microstep emulation, however, the stepper motor runs very smoothly and with excellent performance even in the half step.

## Further settings

The operating behavior of the motor can be set and optimized according to individual requirements by setting the motor-related parameters. The parameters can be set using the NanoPro or NanoCAN software and significantly reduce commissioning time.

Converter cable ZK-RS485-USB or a suitable CAN adapter is needed for the PC connection.

More detailed information on this can be found in the separate NanoPro or NanoCAN user manual.

## 2 Connecting and commissioning

### 2.1 Overview

#### Connectors

The controller has the following connectors:

X1: Hall sensor

X2: Encoder

X3: Motor and power supply

X4 and X5: Inputs and outputs

X14: Communication (RS485/CAN)

#### Jumper RS485/CAN

The controller has a jumper field (X11/X12) for selecting the communication port (RS485 or CAN).

#### Arrangement

The following figure shows the arrangement of the connectors and the jumper on the printed circuit board.

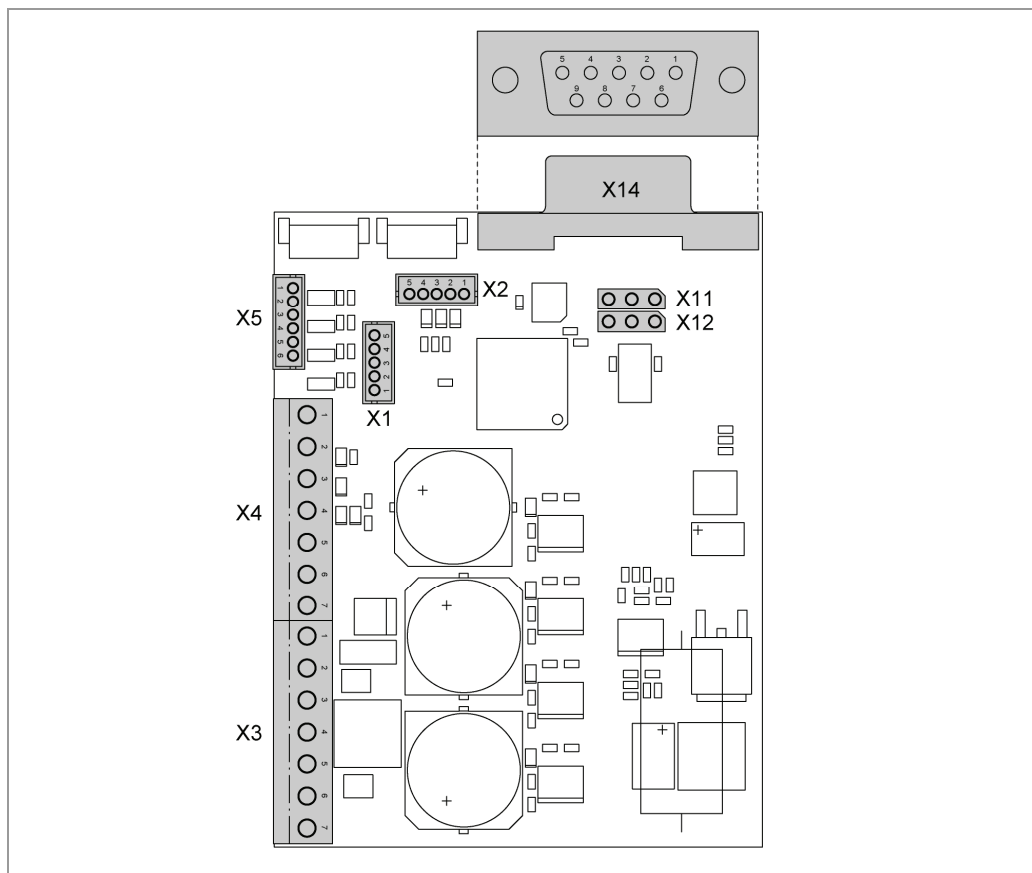

## 2.2 Stepper motor

### Connection diagram

To operate a stepper motor using the SMCI36, the wiring must be implemented according to the following connection diagram.

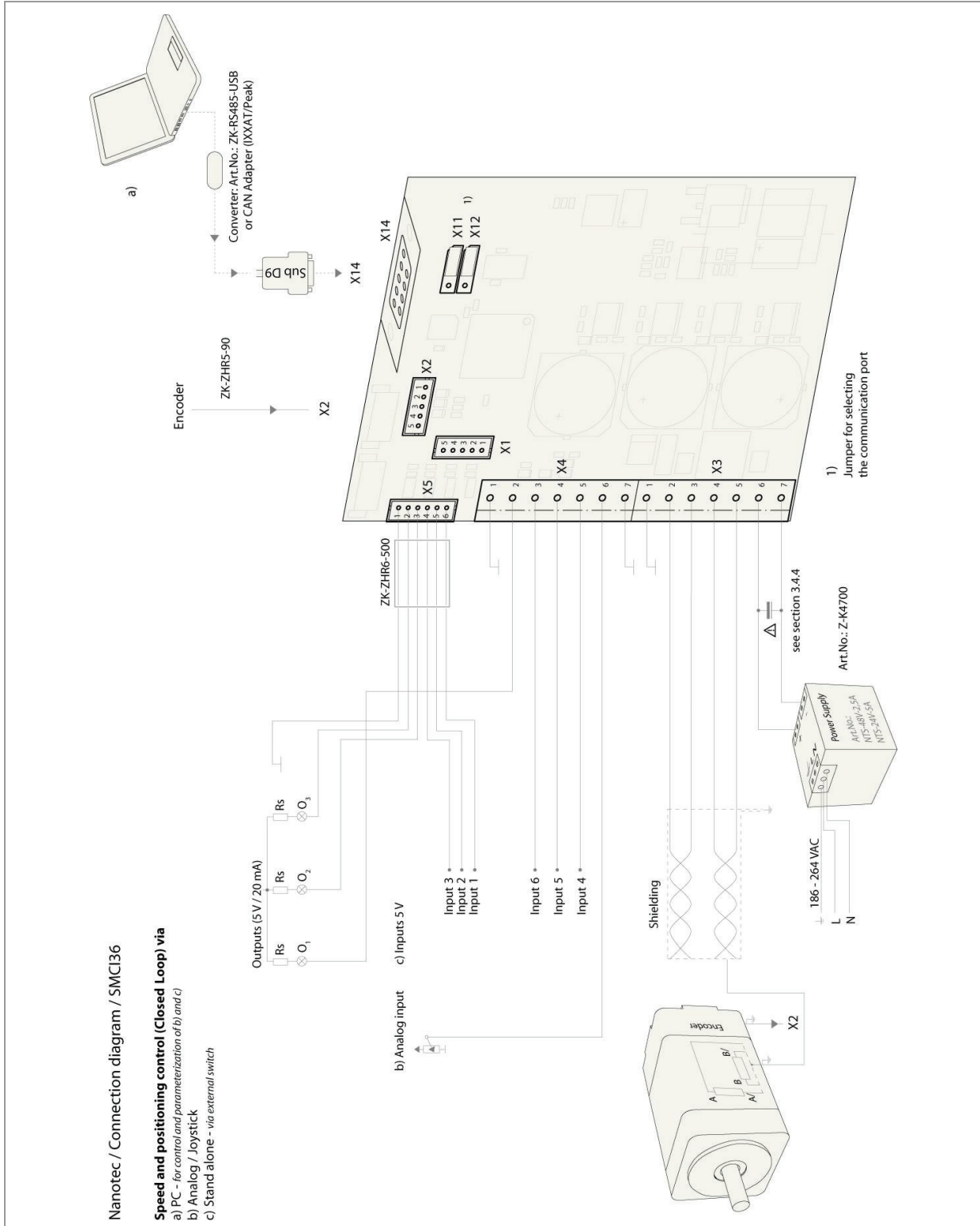

The pin configuration for the motor can be found on the motor data sheet, which can be downloaded from [www.nanotec.com](http://www.nanotec.com).



## 2.3 BLDC motor

### Connection diagram

To operate a BLDC motor using the SMC136, the wiring must be implemented according to the following connection diagram.

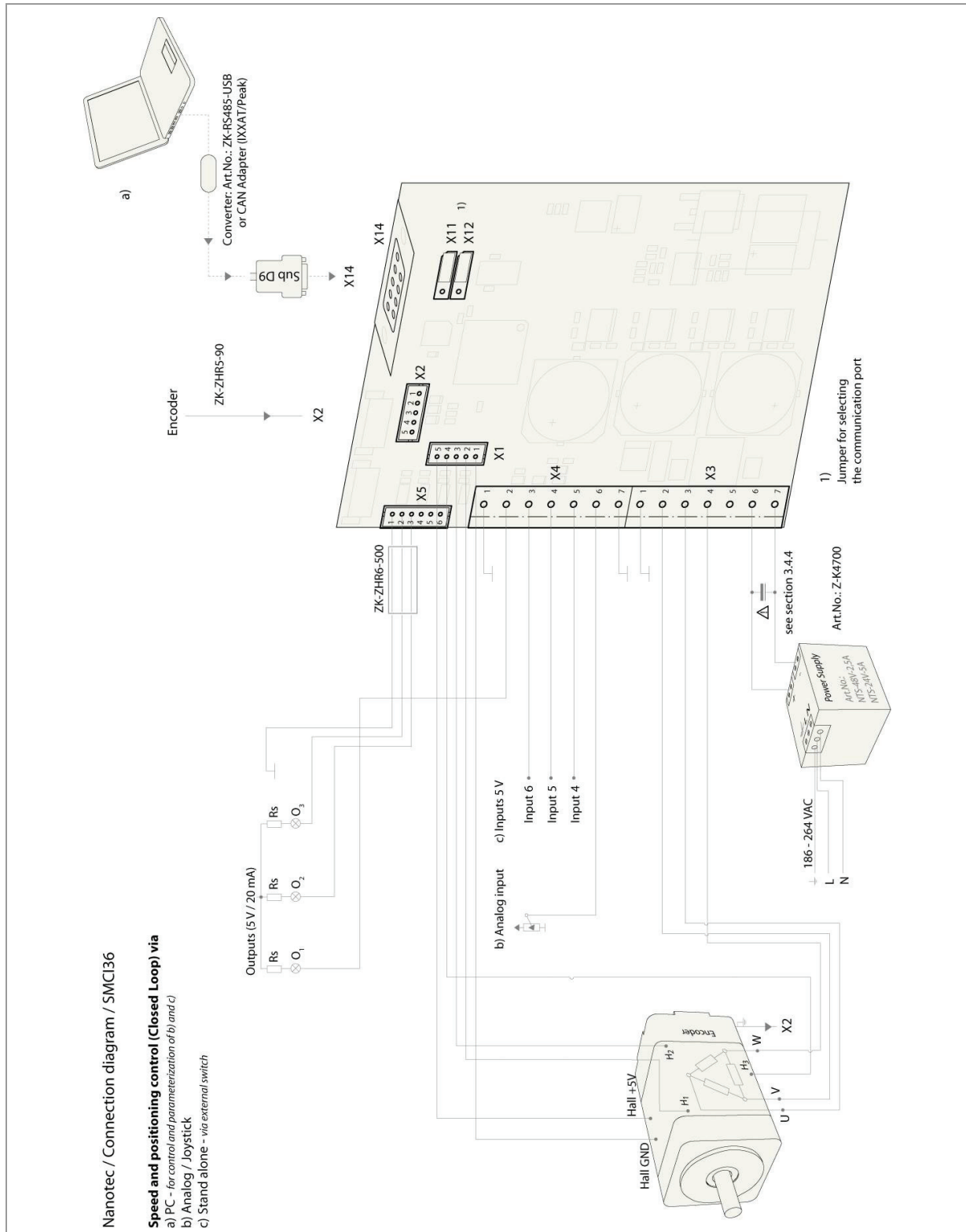

The pin configuration for the motor can be found on the motor data sheet, which can be downloaded from [www.nanotec.com](http://www.nanotec.com).

## 2.4 Commissioning

### Introduction

Commissioning of the SMCI36 motor controller is described below.

If you want to work with a PLC or your own program later, you will find the necessary information in the separate "Programming Manual".

Familiarize yourself with the SMCI36 controller and the corresponding control software before you configure the controller for your application.

This section describes the main first steps you need to take to be able to begin working with the SMCI36 and the NanoPro software (RS485) or NanoCAN software (CANopen) from a PC. You will find more detailed information in the separate NanoPro and NanoCAN manuals.

### Operation with presettings

The SMCI36 is delivered with the following presettings:

- Operating mode: Positioning
- Step mode: Half step (with microstep emulation)
- Inputs on connectors X4/X5 (all 5 V):
  - Input 6 = external reference switch
  - Input 5 = record selection bit 3
  - Input 4 = record selection bit 2
  - Input 3 = record selection bit 1
  - Input 2 = record selection bit 0
  - Input 1 = start/reset
- Phase current: 50%
- Phase current during idle: 25%

### Commissioning with NanoPro

Proceed as follows when commissioning the controller with NanoPro:

Step	Action	Note
1	Install the NanoPro controller software on your PC. See the separate NanoPro manual.	Download from <a href="http://www.nanotec.com">www.nanotec.com</a>
2	Connect the controller to the stepper motor according to the connection diagram.	Connection diagram, see Section 2. Detailed information on connections can be found in Section 3.
3	Switch on the operating voltage (12 V DC ... 72 V DC). <b>CAUTION!</b> An operating voltage > 75 V will destroy the output stage! • Follow the instructions in Section 3.4.4.	The red LED lights up briefly.
4	If necessary, install the driver for the converter cable ZK-RS485-USB.	Download from <a href="http://www.nanotec.com">www.nanotec.com</a> under the Accessories/Converter menu item

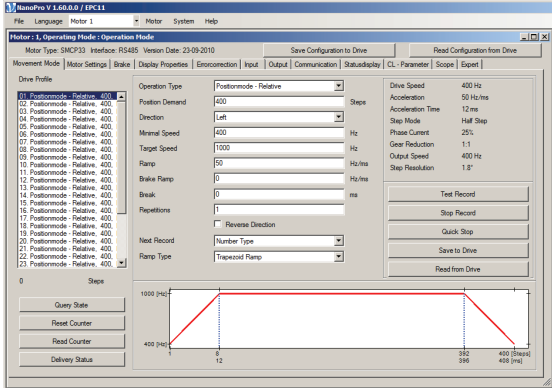
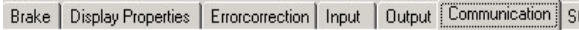
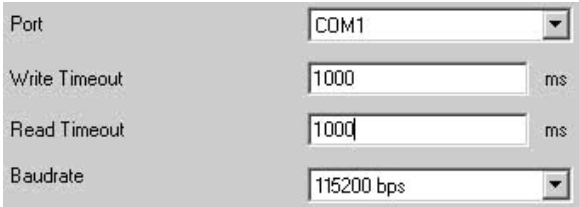
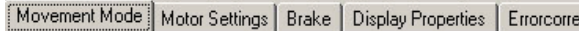
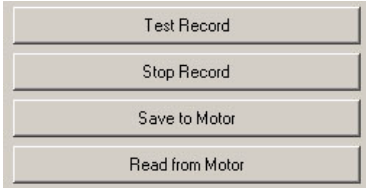
Step	Action	Note
5	Connect the controller to the USB port of your PC. Use the converter cable ZK-RS485-USB.	Order identifier: • ZK-RS485-USB
6	Start the NanoPro software. 	The NanoPro main menu opens.
7	Select the <Communication> tab. 	
8	In the "Port" field, select the COM port to which the SMCI36 is connected. 	The number of the COM port to which the controller is connected can be found in the device manager of your Windows PC (System Control/System/Hardware).
9	Select the "115200 bps" entry in the "Baudrate" selection field.	
10	Check the current setting using the motor data sheet.	Under no circumstances may the current be set to a value higher than the rated current of the motor.
11	Select the "Movement Mode" tab. 	
12	Click on the <Test Record> button to perform the preset travel profile. 	The connected motor runs with the preset travel profile (default travel profile for new installations).
13	You can now enter your required settings. For instance, you can enter a new travel profile.	See the separate NanoPro manual.

### Commissioning with NanoCAN

Proceed as follows when commissioning the controller with NanoCAN:

Step	Action	Note
1	Install the NanoCAN control software on your PC.	Download from <a href="http://www.nanotec.com">www.nanotec.com</a>
2	Connect the controller to the stepper motor according to the connection diagram.	Connection diagram, see Section 2. Detailed information on connections can be found in Section 3.
3	Switch on the operating voltage (12 V DC ... 72 V DC). <b>CAUTION!</b> An operating voltage > 75 V will destroy the output stage! <ul style="list-style-type: none"> <li>Follow the instructions in Section 3.4.4.</li> </ul>	
4	Install and configure your CANopen adapter from IXXAT or Peak.	Details can be obtained from the manufacturer of the CANopen adapter.
5	Start the NanoCAN software.	
6	Select the desired node ID, the baud rate and, if necessary, the CAN card in the <Configuration & NMT> tab.	
7	Select the desired operating mode (e.g. PP mode) in the <Drive Modes> tab.	
8	Click on the <Power on> button.	
9	Enter the desired target position in the "target" field.	
10	Click on the <Start> button.	

## 3 Connections and wiring

### 3.1 Hall sensor: Connector X1

#### Pin assignment

Pin no.	Name	Remark
1	GND	
2	Hall 1	
3	Hall 2	
4	Hall 3	
5	+5 V	

### 3.2 Inputs and outputs: Connectors X4 and X5

#### Introduction

An overview of the assignments can be found in the connection diagram in Section 2. This section looks in detail at the assignments, functions and wiring of connectors X4 and X5.

#### Pin assignment X4

Pin no.	Name	Remark
1	GND	
2	Output 1	Open collector output (max. 24 V, 0.5 A)
3	Input 6	Digital inputs (max. +5 V)
4	Input 5	
5	Input 4	
6	Analog In	Analog input (−10 V ... +10 V)
7	GND	

#### Pin assignment X5

The X5 connector is a JST-ZHR6 connector.  
Suitable connection cable: ZK-ZHR6-500 (length 500 mm, single-conductor).

Pin no.	Name	Remark
1	GND	
2	Output 3	Open collector outputs (max. 24 V, 0.5 A)
3	Output 2	
4	Input 3	Digital inputs (max. +5 V) In BLDC motors, inputs 1 to 3 cannot be used.
5	Input 2	
6	Input 1	

### Function of the inputs

All digital inputs – with the exception of the "Clock" input in the clock directional mode – can be freely programmed using the NanoPro software (e.g. as a limit position switch, enable, etc.) and can be used for sequential control with NanoJ.

All inputs can be configured for "active-high" (PNP) or "active-low" (NPN) with NanoPro.

### Signal status at the outputs

The following table shows the possible signal states at outputs 1 to 3:

Signal statuses			Meaning
Output 3	Output 2	Output 1	
	0	0	Rotation monitoring (error) or limit switch
	0	1	Motor idle (waiting for new command)
	1	0	Busy (controller processing last command)
	1	1	Reference point or zero point reached
1			Excess temperature or undervoltage

The outputs can be freely programmed using the NanoPro software.

**Note:**

Output 3 is also used to display errors and when switching on the controller.

### Input wiring

**Note:**

The voltage must not exceed 5 V. To switch off safely, it must drop below 2 V and to switch on safely, it must be at least 4.5 V.

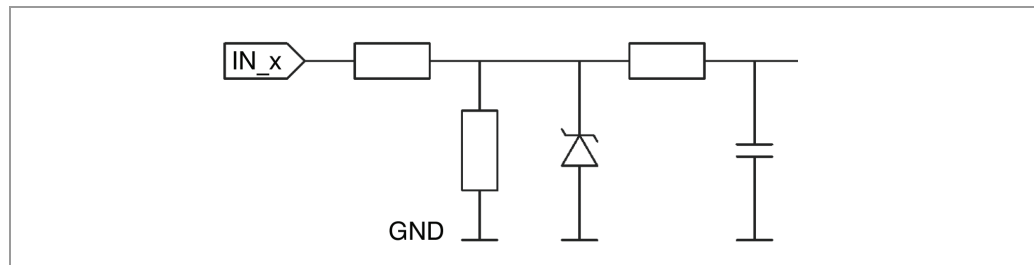

### Output wiring

The outputs are open collector outputs (0 switching; max. 24 V, 0.5 A). To be able to test the output, an LED with series resistance can be integrated. The LED lights up when the output is active.

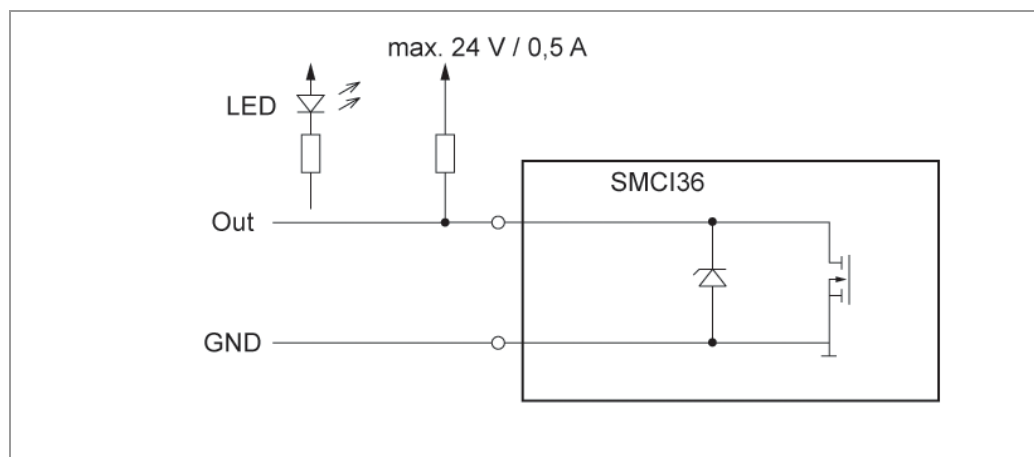

### 3.3 Encoder connection: Connector X2

#### Pin assignment

The X2 connector is a JST-ZHR5 connector.  
Suitable connection cable: ZK-ZHR5-90 (length 90 mm, single-conductor).

Pin no.	Name	Remark
1	GND	
2	Track (B)	
3	Index track (I)	
4	Track (A)	
5	+5 V	

#### Optional encoder

An optional encoder can be connected to the controller.

By default, the control for a three-channel encoder is set up with 500 pulses/revolution in an 1.8° stepper motor. With an 0.9° stepper motor, you should use an encoder with 1000 pulses/revolution to achieve the same control quality. Depending on the application, it may make sense to use higher encoder resolutions (up to max. 2000 pulses/revolution) to improve control quality or to use a lower resolution (min. 200 pulses/revolution) for low-cost applications or for step monitoring alone.

The following encoder resolutions can be processed by the controller: 192, 200, 400, 500, 512, 1000, 1024, 2000, 2048.

#### Recommendation

If possible, use Nanotec encoders with the order identifier WEDS/WEDL-5541 Xxx.

If an encoder is **not** used, the "Disable" mode must be set in the "Error correction" tab in the "Rotation Direction Mode" selection menu. See the separate NanoPro manual.

#### Using encoders with line drivers

WEDL series encoders with a line driver output an inverted signal in addition to the encoder signal; this leads to better interference immunity and is especially recommended for long lines lengths (> 500 mm) and neighboring interference sources. The differential signal can be evaluated with a line driver/encoder adapter.

Since the SMCI36 is designed for device installation, the differential signals are not evaluated so that only channels A, B and I need to be connected to perform position monitoring. We recommend shielding and twisting the encoder line to minimize interference with the encoder signal from the outside.

If the line length in your application exceeds 500 mm, or if there is interference on the lines due to other sources, we recommend the use of controller SMCI33 or SMCI47-S, for which there is an adapter for encoders with a line driver.

## 3.4 Motor and power supply connection: Connector X3

### 3.4.1 Pin assignment

Pin no.	Name	Remark
1	GND	Earth (0 V)
2	A	See the data sheet of the connected stepper motor.
3	A/	In BLDC motors:
4	B	• A = V
5	B/	• A/ = U
		• B = W
		• B/ = not connected
6	Vcc	Operating voltage +12 V DC ... +72 V DC
7	GND	Earth (0 V)

### 3.4.2 Stepper motor connection

#### General information

The motor is connected to the SMCI36 with a 4-wire cable. Twisted wire pair cables with braided shields are recommended.



#### **Danger of electrical overvoltage**

Accidentally swapping the connections will destroy the output stage. See the data sheet of the connected stepper motor.

Never disconnect the motor while operating voltage is applied!

**Never** hot-unplug lines.

### 3.4.3 BLDC motor connection

See Section 2.3 "BLDC motor".



### 3.4.4 Power supply connection

#### Permissible operating voltage

The permissible operating voltage for the SMC136 lies between +12 and +72 V DC; it must not exceed 75 V or fall below 10 V.

A charging capacitor with minimum 4700 µF (10000 µF) must be provided for the operating voltage to prevent exceeding the permissible operating voltage (e.g. during braking).

	<p><b>Danger of electrical overvoltage</b></p> <p>Connect a charging capacitor with minimum 4700 µF! Use charging capacitors Z-K4700 from Nanotec to a maximum operating voltage of 50 V only!</p> <p>Connect a capacitor with 10000 µF for motors with flange size 86x86 (series ST8918) or greater!</p> <p>An operating voltage &gt; 75 V will destroy the output stage! Accidentally swapping the connections will destroy the output stage. See the data sheet of the connected stepper motor.</p> <p>Never disconnect the motor while operating voltage is applied! <b>Never</b> hot-unplug lines.</p>
---	---

#### Connection diagram

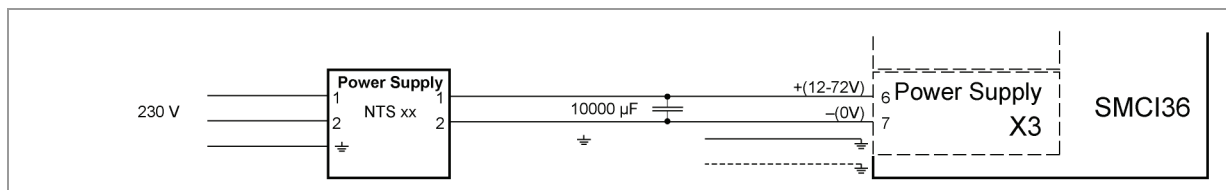

**Note:**  
Overall connection diagram, see Section 2 "Connecting and commissioning".

#### Accessories

Appropriate power packs and charging capacitors are available as accessories:

Designation	Order identifier
Power pack	NTS-xxV-yA (xx=voltage, y=current) Information on the selection of the required power supply unit can be found in our FAQ on <a href="http://www.nanotec.com">www.nanotec.com</a> .
Charging capacitor	Z-K4700 (to max. 50 V) or Z-K10000

**Note:**  
Further information about accessories can be found on the Nanotec website [www.nanotec.com](http://www.nanotec.com).

## 3.5 RS485 network/CANopen: Connector X14

### SMCI36 in a network

Up to 254 (RS485) or 127 (CANopen) stepper motor controls can be controlled in a network from a PC or PLC.

These network connections are set up via the RS485/CANopen port.

### Pin assignment

Pin no.	Name	Remark
1	NC	Not assigned
2	Rx+ / CAN-	RS485 Rx+ / CAN low
3	CAN GND	Output GND (0 V)
4	Tx+	RS485 Tx +
5	NC	Not assigned
6	GND	Output GND (0 V)
7	Rx- / CAN+	RS485 Rx- / CAN high
8	GND	Output GND (0 V)
9	Tx-	RS485 Tx -

### Jumper RS485/CAN

The controller has a jumper field (X11/X12) for selecting the communication port (RS485 or CAN).

When setting, note the copper label on the printed circuit board.

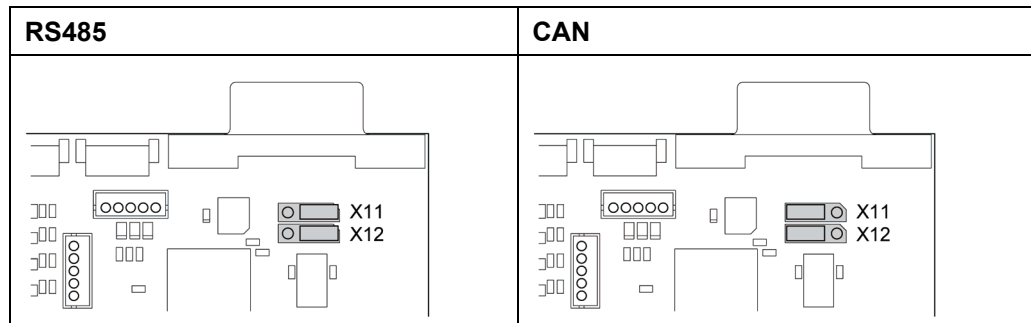

**RS485 network power circuit diagram**

**CONNECTION DIAGRAM RS485 NETWORK CONTROLLER**

- 2...254 units
- If there are more than two units Pin8 (GND) has to be connected to each unit.
  - GND and the shielding must be connected in each end.
- In disregard of the above points the controller could be destroyed
- If there are more than two units Pin8 (GND) has to be connected to each unit.
  - The last unit in each end of the line must be terminated with 120Ω.
  - the cable must be shielded twisted pair 6x0.2mm<sup>2</sup> (AWG24)
  - the max. cable length of the network cable is 5m.
- Disregard of the above points the controller could be not functional, because irregularity can be applied into the inputs and the communication lines and thus may be arise the considered errors in the processes .
- before connecting the unit to the network, every unit must get his own module number via Nanopro programm.

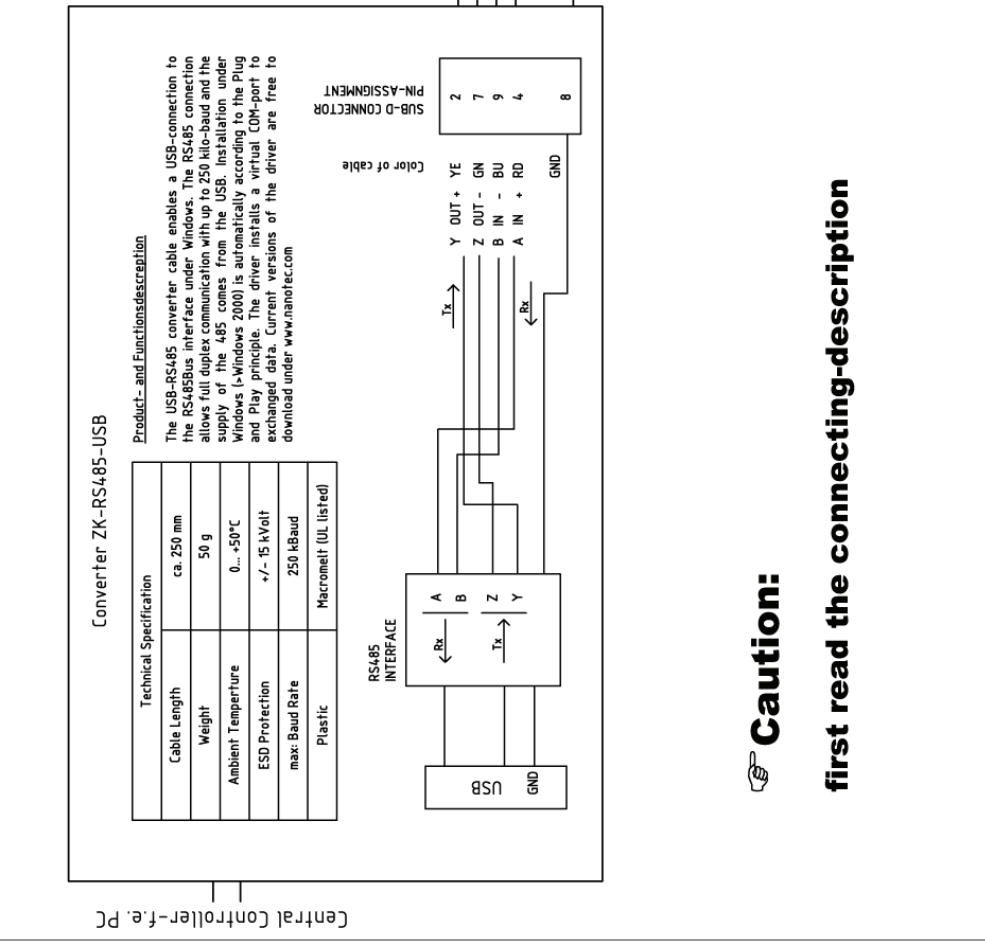
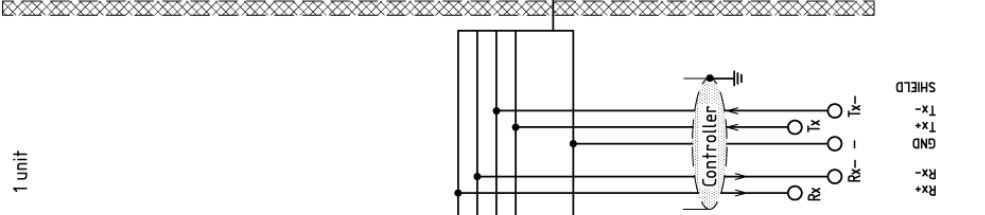

Converter ZK-RS485-USB

Product- and Functionsdescription

The USB-RS485 converter cable enables a USB-connection to the RS485Bus interface under Windows. The RS485 connection allows full duplex communication with up to 250 kilo-baud and the supply of the 485 comes from the USB. Installation under Windows (Windows 2000) is automatically according to the Plug and Play principle. The driver installs a virtual COM-port to exchanged data. Current versions of the driver are free to download under [www.nanotec.com](http://www.nanotec.com)

Technical Specification	
Cable Length	ca. 250 mm
Weight	50 g
Ambient Temperature	0... +50°C
ESD Protection	+/- 15 kVolt
max. Baud Rate	250 kBaud
Plastic	Macromet (UL listed)

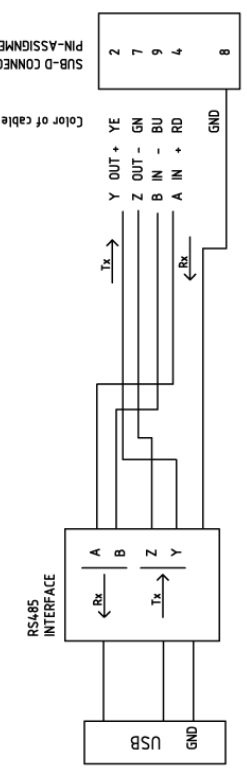

**Caution:**  
first read the connecting-description

### CANopen connection

A suitable CAN interface adapter (e.g. USB adapter from IXXAT or PEAK) is required for connecting with a PC.

#### CANopen standard connector assignment (on the adapter)

Pin no.	Name
2	CAN low
3	CAN GND
7	CAN high

#### CANopen connection assignments on the controller

Circuits according to the CANopen standard connector assignment, see preceding table.

#### Notes on the baud rate

It is important to note that both the controller and the CAN master use the same baud rate. Only this way can communication be established.

The baud rate has a direct influence on the maximum possible bus length. The following list shows the possible baud rates as well as their maximum permissible bus lengths:

Baud rate	Bus length
1 MBaud	40 m
500 kBaud	130 m
250 kBaud	270 m
125 kBaud	530 m
50 kBaud	1300 m
20 kBaud	3300 m

#### Notes on the bus termination

With CAN, the bus termination is handled by two 120 Ohm resistors on both ends of the bus.

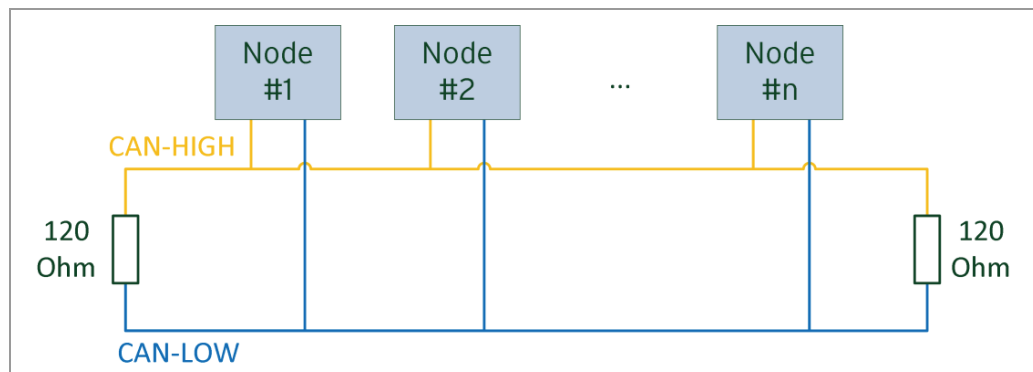

## Setting the RS485 module address

### Hardware setting

The RS485 module address can be set by hardware via two HEX coded switches on the printed circuit board.

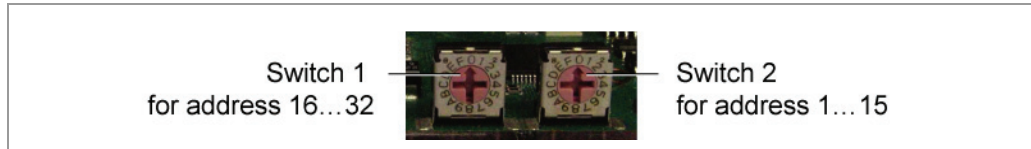

The 16's place is set with switch 1 (left) and the 1's place is set with switch 2 (right).

Module address	Switch 2 (right)	Switch 1 (left)
Software setting	0	0
1	1	0
2	2	0
...	...	...
15	F	0
16	0	1
17	1	1
...	...	...
32	0	2
...	...	...
64	0	3
...	...	...
80	0	5
...	...	...
96	0	6
...	...	...
112	0	7
...	...	...
255	F	F

When the power supply is applied, the controller checks which address is set with the 2 hardware switches. This hardware address is then adopted. After the address is changed, the power supply must be briefly switched off and on again.

### Software setting

Both switches are set to 0 at delivery. With this setting, the address can be changed in the software as of firmware status 04 December 2008 or later. See the separate NanoPro manual.

### Setting the CANopen module address

There are two basic ways of setting the CANopen node ID and the baud rate:

- Hardware setting: using the rotary switch on the controller
- Software setting: using NanoCAN, see separate NanoCAN manual.

To be able to make a software setting with NanoCAN, a certain value must be set on the rotary switches of the control; see the following table:

Rotary switch value dec (hex)	Node ID	Baud rate
<b>0</b> (0x00)	From EEPROM	= 1 MBaud
<b>1 - 127</b> (0x01 - 0x7F)	= rotary switch value	
<b>128</b> (0x80)	From EEPROM	From EEPROM
<b>129 - 255</b> (0x81 - 0xFF)	= rotary switch value minus 128	

**Note:**

The rotary switches must be set to the desired value before the control is switched on since this value is only read in when the control is restarted.

The rotary switches can be used to set a two-digit hexadecimal number (0x00 to 0xFF):

- Right rotary switch: 1's place (e.g. 0x0F)
- Left rotary switch: 16's place (e.g. 0xF0)

**Example 1:**

If the left rotary switch is set to 2 and the right rotary switch is set to 1 (0x21), this yields a decimal value of 33 (= 2\*16 + 1\*1).

In this case, the node ID is set to 33 on the hardware. The baud rate is set to 1 MBaud.

**Example 2:**

If the left rotary switch is set to 8 and the right rotary switch is set to 0 (0x80), this yields a decimal value of 128 (= 8\*16 + 0\*1).

In this case, the node ID and baud rate are read out of the EEPROM.

## 4 Operating modes

### 4.1 Serial operating modes

#### Introduction

Depending on the travel profile, the motor can be operated using different operating modes. Due to its powerful performance and functional variety, it offers designers and developers a rapid and simple method of resolving numerous drive requirements with less programming effort.

Select the required operating mode for each travel profile and configure the controller according to your requirements.

More detailed information can be found in the separate NanoPro manual.

#### Overview of operating modes and their areas of application

Operating mode	Application
Relative positioning	Use these modes to travel to a specific position.
Absolute positioning	The motor travels according to a specified travel profile from a Position A to a Position B.
Internal reference run	During the internal reference run, the motor travels to an internal reference point (the index mark of the encoder; only in combination with an encoder) at the set minimum speed.
External reference run	During an external reference run, the motor travels to a switch connected to the reference input.
Speed mode	Use this mode when you wish to travel with a specific speed (e.g. a conveyor belt or pump speed). In the speed mode, the motor accelerates with a specified ramp from the starting speed ("V Start" start frequency) to the specified maximum speed ("V Normal" maximum frequency). With multiple inputs, the rpm can be regulated to different speeds on the fly.
Flag positioning mode	The flag positioning mode offers a combination of the speed and positioning modes. The motor is initially operated in speed mode; when a trigger point is reached, it changes to the positioning mode and travels to the specified setpoint position (relative to the trigger position). Use of this operating mode for purposes such as labeling: The motor first accelerates to the synchronous speed of the conveyed product with the set ramp. When the labels are detected, the preset distance (position) is traveled to apply the labels.

Operating mode	Application
Clock direction mode, left	Use this mode when you wish to operate the motor with a higher-order controller (e.g. CNC controller). In the clock direction mode, the motor is operated via two inputs by a higher-order positioning controller (indexer) with one clock signal and one directional signal. Depending on the mode selected (Int. Ref./Ext. Ref.), the internal or external reference run is supported.
Clock direction mode, right	
Clock direction mode Int. Ref.	
Clock direction mode Ext. Ref.	
Analog and joystick mode	The motor is simply controlled in this operating mode with a potentiometer or a joystick (-10 V to +10 V). Use this mode if you want to use the motor in a simple application: <ul style="list-style-type: none"> <li>• Setting a specific speed, e.g. via an external potentiometer,</li> <li>• Traveling synchronously with a higher-order controller with analog output (-10 V to +10 V).</li> </ul>
Analog positioning mode	Use this mode to travel to a specific position. The voltage level on the analog input is proportional to the required position.
Torque mode	Use this mode if you wish require a specific output torque, independent of the speed, as is the case in typical winding and unwinding applications. The maximum torque is specified via the analog input.

**Selecting the operating mode in NanoPro**

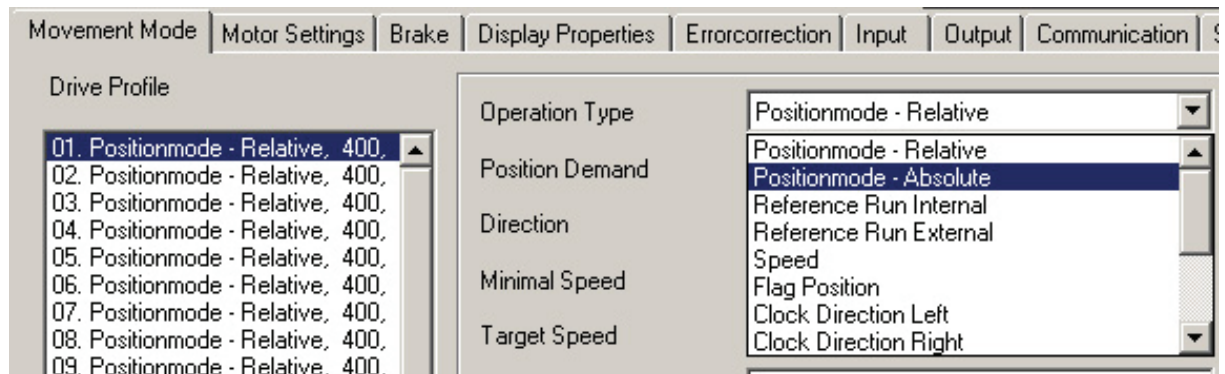



## 4.2 CANopen operating modes

### Introduction

The motor can be operated using a total of 5 different operating modes in CANopen mode.

More detailed information can be found in the separate NanoCAN manual.

### Overview of operating modes and their areas of application

Operating mode	Application
Positioning Mode (PP Mode)	Use this mode if you want to use the motor for positioning. The motor moves from A to B with the set parameters (ramp, speed, etc.).
Speed Mode (velocity Mode)	Use this mode when you wish to travel with a specific speed (e.g. a conveyor belt).
Reference run (ref. mode/homing mode)	Use this mode to reference the motor (internal/external/on block).
Interpolated Position Mode	Use this mode with a higher-order path control.
Torque Mode	Use this mode to specify a defined torque.

### Selecting the operating mode in NanoCAN

In the <Drive Modes> tab the operating mode can be selected. When the tab is activated, the corresponding SDO is immediately written to the controller to activate the (possibly previously) selected operating mode.

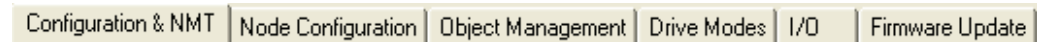

## 5 Troubleshooting

### Troubleshooting procedure

Proceed with care during troubleshooting and error rectification to avoid damaging the controller.



#### **Danger of electrical overvoltage**

An operating voltage > 75 V and swapping of the connections can destroy the output stage.

Never disconnect the motor while operating voltage is applied!

Never hot-unplug lines.

### Possible errors in serial mode

Error	Possible cause	Elimination
Controller is not ready	Data transmission to SMCI36 is not possible (communication error): Wrong COM port selected.	In the <Communication> tab, select the PC port to which you connected the SMCI36 (e.g. "COM-1"). The port used can be found in the device manager of your PC.
	Wrong baud rate setting.	Select the baud rate 115200 bps in the <Communication> tab.
	The communication cable is not connected or is interrupted.	Only use the recommended ZK-RS485-USB converter from Nanotec.
	A non-existent motor number (module number) is set.	Set the correct module address. See separate NanoPro manual.
	The power supply of the SMCI36 is interrupted.	Check power supply, switch on if necessary.
	Another open program is blocking the COM port to which the SMCI36 is connected.	Close the other programs on your PC.
	Inadmissible data was sent to the controller during the output of a travel profile.	Click on the <Yes> button to stop the travel profile. The SMCI36 switches back to the "Ready" state. The data can then be resent to the controller.
Transmission fault	Data transmission to the SMCI36 is disturbed (sender or receiver are disturbed).	Check that the motor connection is correctly wired. We recommend using Nanotec converter ZK-RS485-USB.
Position error	The motor cannot reach the position or the limit switch was overrun.	Click the <Yes> button in the error message; the error is reset.

**Possible errors in CANopen mode**

<b>Error</b>	<b>Possible cause</b>	<b>Elimination</b>
No communication with the controller	The wrong node ID has been set.	On the <Configuration & NMT> tab in NanoCAN, select the node ID that is set on the rotary switches of the controller.
	Wrong baud rate setting.	On the <Configuration & NMT> tab in NanoCAN, select the baud rate 1000 kbps.
	The communication cable is not connected or is interrupted.	Check all connections, especially the terminal resistances.
	CAN bus incorrectly terminated with 120 Ohm.	Ideally, terminate the bus on both ends with 120 Ohm.
Transmission fault	Data transmission is disturbed (sporadically).	Switch the power supply off and on again.

## 6 Technical data

### Electrical connections

Operating voltage $V_b$	DC 12 V to 72 V $\pm 4\%$
Max. phase current	Adjustable up to max. 9 A/phase Continuous current 6 A/Phase
Current drop	Adjustable from 0 to 150% of rated current
Port	RS485 (4-wire) CAN bus (CANopen)

### Control parameters

Step resolution	Full step, half step, quarter step, fifth step, eighth step, tenth step, 16th step, 32nd step, 64th step, adaptive microstep, feed rate
Step frequency	16 kHz with a full step, corresponding multiples with a microstep (e.g. 1 MHz with 1/64) Max. input frequency, clock direction mode: 200 kHz
Position monitoring	depending on encoder resolution

### Protective circuits

Overvoltage and undervoltage	Protective circuit for voltages $> 75$ V or $< 10$ V
Max. heat sink temperature	Approx. 75 °C
Max. ambient temperature	0 to 40 °C

### Inputs and outputs

Inputs	<ul style="list-style-type: none"><li>6 digital inputs (TTL, max. 5 V)</li><li>1 analog input (+10 V / -10 V)</li></ul>
Outputs	<ul style="list-style-type: none"><li>3 open collector outputs (max. 24 V, 0.5 A)</li></ul>

### Connector designations

The following connectors are available on the SMCI36:

- Connectors X1, X2 and X5: JST-ZH
- Connectors X3 and X4: RIA type 059 screw terminal, 3.5 mm contact spacing
- Connector X14: D-sub 9-pin, socket (female)

**Dimensions SMCI36**

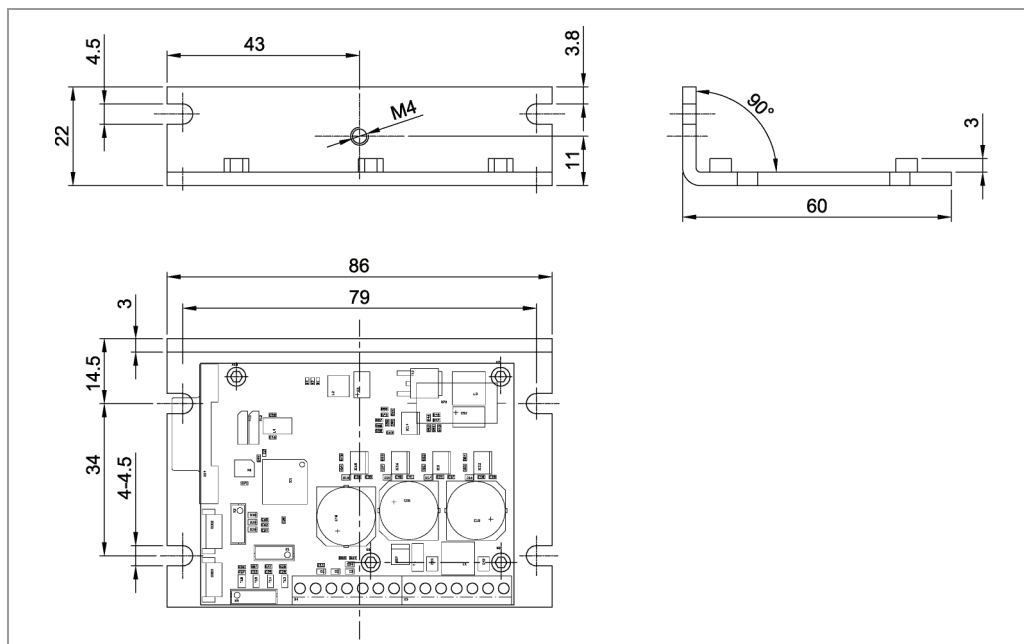

A complete set of data sheets is available for downloading at [www.nanotec.com](http://www.nanotec.com).

## Index

### A

Accessories for voltage supply ..... 17

### B

BLDC motor ..... 9

### C

CANopen ..... 6, 12, 18

Closed-Loop current control ..... 5

Commissioning ..... 10

Connectors ..... 7

### D

dspDrive ..... 6

### E

Encoder ..... 15

### F

Functions ..... 5

### I

Input wiring ..... 14

Inputs ..... 13

### J

Jumper RS485/CANopen ..... 18

### M

Motor connection

BLDC motor ..... 16

Stepper motor ..... 16

### N

NanoJ ..... 6

### O

Operating modes

    CANopen ..... 25

    Serial ..... 23

Operating voltage ..... 17

Output wiring ..... 14

Outputs ..... 13

### P

Pin assignment

    Connector X1 ..... 13

    Connector X14 ..... 18

    Connector X2 ..... 15

    Connector X3 ..... 16

    Connector X4 ..... 13

    Connector X5 ..... 13

Protective circuits ..... 28

### R

RS485 network ..... 18

### V

Voltage supply ..... 17