

Technical Manual



Stepper motor control SMC147-S

NANOTEC ELECTRONIC GmbH & Co. KG
Kapellenstraße 6
D-85622 Feldkirchen b. Munich, Germany

Tel. +49 (0)89-900 686-0
Fax +49 (0)89-900 686-50
info@nanotec.com

Editorial

© 2011

Nanotec[®] Electronic GmbH & Co. KG

Kapellenstraße 6

D-85622 Feldkirchen b. Munich, Germany

Tel.: +49 (0)89-900 686-0

Fax: +49 (0)89-900 686-50

Internet: www.nanotec.com

All rights reserved!

MS-Windows 2000/XP/Vista are registered trademarks of Microsoft Corporation.

Translation of the original operation manual

Version/Change overview

Version	Date	Changes
1.0	02/02/2009	New issue C+P
2.0	07/01/2009	Revision C+P
2.1	11/03/2010	Revision RS485/CANopen
2.2	11/03/2011	Revision C+P

About this manual

Target group

This technical manual is aimed at designers and developers who need to operate a Nanotec[®] stepper motor without much experience in stepper motor technology.

About this manual

This technical manual must be carefully read before installation and commissioning of the controller.

Nanotec[®] reserves the right to make technical alterations and further develop hardware and software in the interests of its customers to improve the function of this product without prior notice.

This manual was created with due care. It is exclusively intended as a technical description of the product and as commissioning instructions. The warranty is exclusively for repair or replacement of defective equipment, according to our general terms and conditions; liability for subsequent damage or errors is excluded. Applicable standards and regulations must be complied with during installation of the device.

For criticisms, proposals and suggestions for improvement, please contact the above address or send an email to: info@nanotec.com

Additional manuals

Please also note the following manuals from Nanotec:

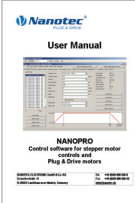
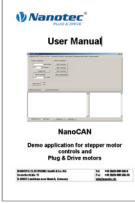
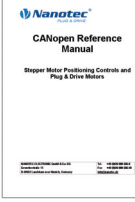
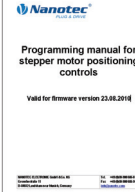
<p>NanoPro User Manual</p>	<p>Configuration of controllers with the NanoPro software</p>	
<p>NanoCAN User Manual</p>	<p>Configuration of the CAN communication for CANopen-capable controllers with the NanoCAN software</p>	
<p>Nanotec CANopen reference</p>	<p>Detailed documentation of the CANopen functions</p>	
<p>Programming manual</p>	<p>Controller programming</p> <ul style="list-style-type: none"> • Command reference • NanoJ • COM interface 	

The manuals are available for download at www.nanotec.com.

Contents

1	Overview	5
2	Connection and commissioning	6
2.1	Connection diagram	6
2.2	Commissioning.....	8
3	Connections and circuits	11
3.1	Inputs and outputs (I/O): Connector X1	11
3.2	Brake connection: Connector X2	13
3.3	Encoder connection: Connector X3	14
3.4	Stepper motor connection: Connector X4.....	15
3.5	Voltage supply connection: Connector X5.....	16
3.6	RS485 network/CANopen: Connector X6.....	17
4	Operating modes.....	22
4.1	Serial operating modes (SMCI47-S-2).....	22
4.2	CANopen operating modes (SMCI47-S-3)	24
5	Troubleshooting.....	25
6	Technical data	27
	Index.....	29

1 Overview

Introduction

The stepper motor control SMCI47-S is an extremely compact and cost-effective constant current power output stage with integrated Closed-Loop current control.

Due to the great capacity and functions available, it offers designers and developers a rapid and simple method of resolving numerous drive requirements with less programming effort.

It is used for controlling standard stepper motors (including with attached encoders) or motors with integrated encoders or brakes.

Variants

The SMCI47-S is available in the following variants:

- SMCI47-S-2: For control via RS485
- SMCI47-S-3: For control via CANopen

SMCI47-S functions

The stepper motor control SMCI47-S contains the following functions:

- Microstep -1/1 – 1/64 final output stage (step resolution of up to 0.014° in motor with a step angle of 0.9° in 1/64 step mode)
- Closed-Loop current control (sinusoidal commutation via the encoder)
- Powerful DSP microprocessor for flexible I/O
- Rotation monitoring for optional encoder
- RS485/CANopen interface for parameterization and control (USB connection possible via converter cable ZK-RS485-USB)
- Network capability with up to 254 motors (RS485) or 127 motors (CANopen)
- Easy programming with Windows software NanoPro (RS485) or NanoCAN (CANopen)



Closed-Loop current control (sinusoidal commutation via the encoder):

In contrast to conventional stepper motor positioning controls where only the motor is actuated or the position adjusted via the encoder, sinusoidal commutation controls the stator magnetic field via the rotary encoder as in a servomotor. The stepper motor acts in this operating mode as nothing more than a high pole servomotor, i.e. the classic stepper motor noises and resonances vanish. As the current is controlled, the motor can no longer lose any steps up to its maximum torque.

If the controller recognizes that the rotor is falling behind the stator field due to overload, adjustments are made with optimal field angle and increased current. In the opposite case, i.e. if the rotor is running forward due to the torque, the current is automatically reduced so that current consumption and heat development in the motor and controller are much lower compared to normal controlled operation.



The integrated programming language NanoJ, based on the Java standard, means complete application programs can be realized on the drivers that can be executed independently without a higher-order controller.

The programs can be created, compiled directly and written to the controller with the free NanoJEasy editor.

NanoJ is only supported by the RS485 firmware.

More detailed information can be found in the separate programming manual.

Activation via CANopen



It is possible to include the stepper motor control in a CANopen environment with the SCMI47-S-3.

More detailed information on this can be found in the CANopen reference and in the NanoCAN user manual.

In addition, the stepper motor control via CANopen has another safety function: Even when the voltage supply of the stepper motor control is interrupted, the processor continues to be supplied with power via the communication line and the position data cannot be lost so that the machine does not need to be referenced after being switched on.

Settings

The operating behavior of the motor can be set and optimized according to individual requirements by setting the motor-related parameters. The parameters can be set using the NanoPro software and significantly reduce commissioning time.

More detailed information on this can be found in the separate NanoPro user manual.

Rotation monitoring

Even if stepper motors do not lose steps during normal operation, the integrated speed control provides additional security in all operating modes, e.g. against motor stalling or other external sources of error. The monitoring function detects a stalled motor or step loss after half a step at the most (for 1.8° stepper motors).

Automatic error correction is possible after the drive profile is ended or during the drive.

2 Connection and commissioning

2.1 Connection diagram

Introduction

In order to operate a stepper motor using the stepper motor control SMCI47-S, you must carry out the wiring in accordance with the connection diagram below.

Connectors X1 and X3 can be optionally used.

Nanotec / Connection diagram / SMCI 47-S-2 (RS 485) / SMCI 47-S-3 (CanOpen)

Speed and positioning control (Closed Loop) via

- a) PC - for control and parameterization of c, d) and e)
- b) Industrial control system
- c) SPS - e.g. Logo or Easy
- d) Analog / Joystick
- e) Stand alone - via external switch

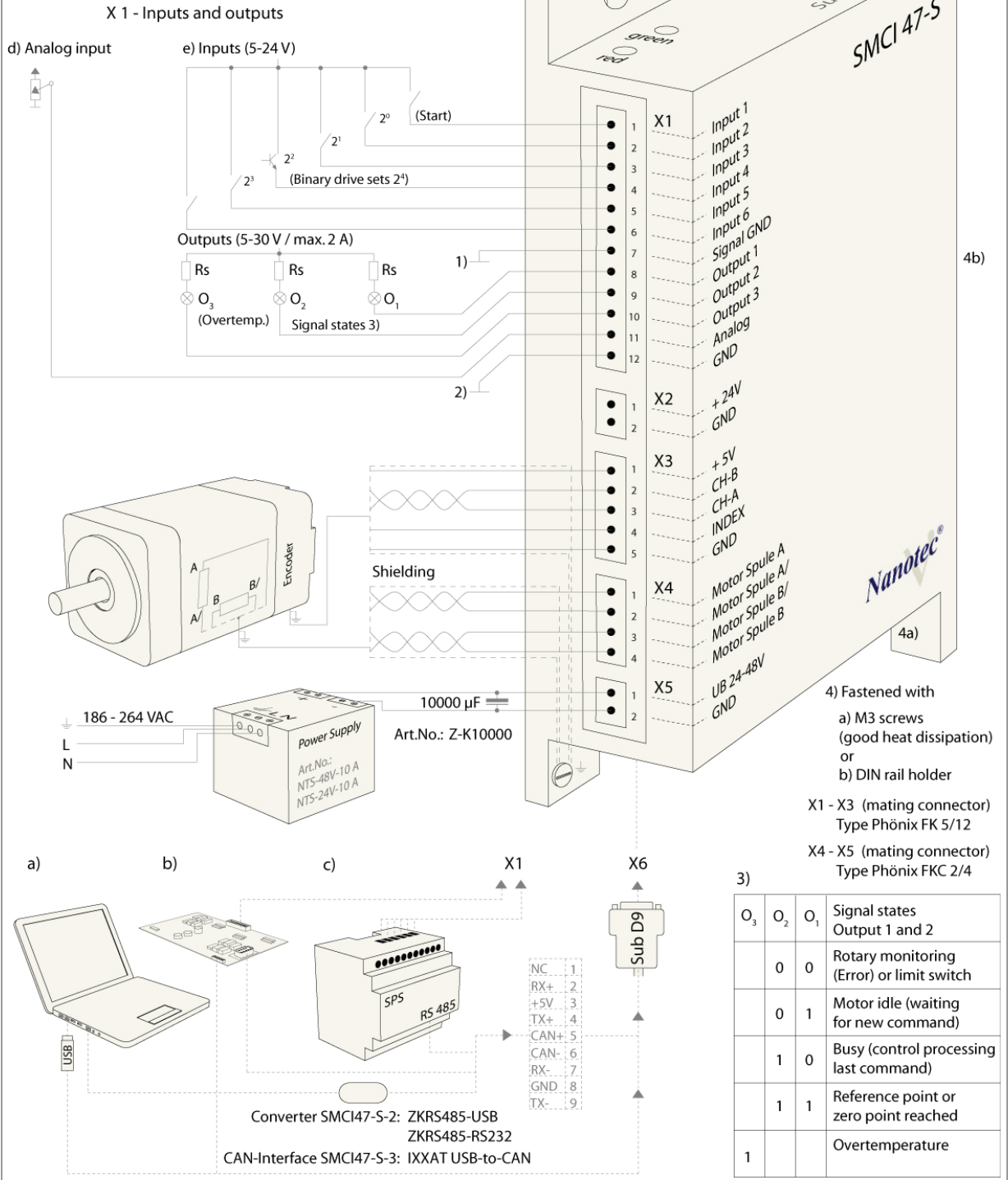

2.2 Commissioning

Introduction

The connection and commissioning of the SMCI47-S stepper motor control are described below.

If you want to work at a later time with a PLC or your own program, you will find the necessary information in the separate "Command Reference".

Familiarize yourself with the SMCI47-S stepper motor control and the corresponding control software before you configure the controller for your application.

This section describes the main first steps you need to take to be able to begin working with the SMCI47-S and the NanoPro software (RS485) or NanoCAN software (CANopen) from a PC. You will find more detailed information in the separate NanoPro and NanoCAN manuals.

Commissioning with NanoPro (SMCI47-S-2)

Proceed as follows to commission the SMCI47-S-2 controller:

Step	Action	Note
1	Install the NanoPro control software on your PC. See the NanoPro separate manual.	Download of www.nanotec.com
2	Connect the controller to the stepper motor according to the connection diagram.	Connection diagram, see Section 2.1. Detailed information on connections can be found in Chapter 3.
3	Switch on the operating voltage (24 V DC ... 48 V DC). CAUTION! An operating voltage > 50 V will destroy the output stage! <ul style="list-style-type: none"> Follow the information in Section 3.5. 	The green LED lights up.
4	If necessary, install the converter driver for the converter cable ZK-RS485-USB.	Download www.nanotec.com in the Accessories/Converter menu item
5	Connect the controller with your PC. Use one of the following converter cables for this purpose: <ul style="list-style-type: none"> ZK-RS485-RS232 for connection to the serial interface ZK-RS485-USB for connection to the USB interface 	Order number: <ul style="list-style-type: none"> ZK-RS485-RS232 ZK-RS485-USB

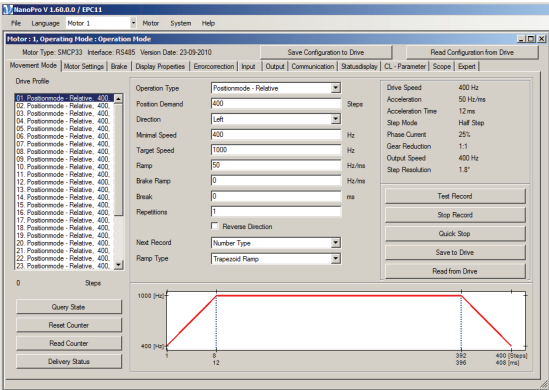
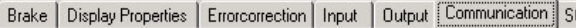
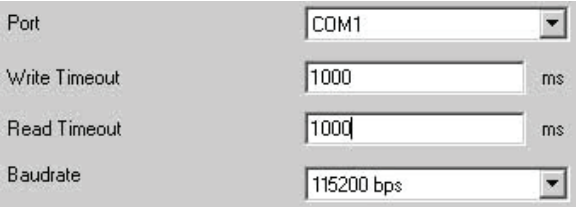
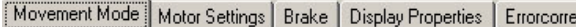
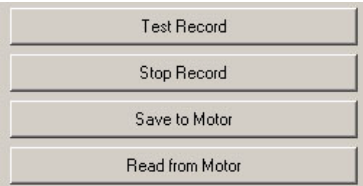
Step	Action	Note
6	<p>Start the NanoPro software.</p> 	The NanoPro main menu appears.
7	<p>Select the <Communication> tab.</p> 	
8	<p>In the "Port" field, select the COM port to which the SMCI47-S is connected.</p> 	The number of the COM port to which the controller is connected can be found in the device manager of your Windows PC (System Control/System/Hardware).
9	<p>Select the "115200 bps" entry in the "Baudrate" selection field.</p>	
10	<p>Check the current setting using the motor data sheet.</p>	Under no circumstances may the current be set to a value higher than the rated current of the motor.
11	<p>Select the "Movement Mode" tab.</p> 	
12	<p>Click on the <Test Record> button to carry out the pre-set travel profile.</p> 	The connected motor operates with the pre-set travel profile (default travel profile after new installation).
13	<p>You can now enter your required settings. For instance, you can enter a new travel profile.</p>	See the NanoPro separate manual.

Commissioning with NanoCAN (SMCI47-S-3)

Proceed as follows to commission the SMCI47-S-3 controller. More detailed information can be found in the separate NanoCAN manual.

Step	Action	Note
1	Install the NanoCAN control software on your PC.	Download of www.nanotec.com
2	Connect the controller to the stepper motor according to the connection diagram.	Connection diagram, see Section 2.1. Detailed information on connections can be found in Chapter 3.
3	Switch on the operating voltage (24 V DC ... 48 V DC). CAUTION! An operating voltage > 50 V will destroy the output stage! <ul style="list-style-type: none"> Follow the information in Section 3.5. 	
4	Install and configure your CANopen adapter.	Details can be obtained from the manufacturer of the CANopen adapter.
5	Start the NanoCAN software.	
6	Select the desired node ID, the baud rate and, if necessary, the CAN card in the <Configuration & NMT> tab.	
7	Select the desired operating mode (e.g. PP mode) in the <Drive Modes> tab.	
8	Click on the <Power on> button.	
9	Enter the desired target position in the "target" field.	
10	Click on the <Start> button.	

3 Connections and circuits

3.1 Inputs and outputs (I/O): Connector X1

Introduction

An overview of the assignments can be found in the wiring diagram in Section 2.1. This section looks in detail at the assignment, functions and circuits of connector X1.

The connectors and sockets used are from Phoenix, order number: FK-MC 2/4/5/12.

Pin assignment

Pin no.	Name	Observations
1	Input1	5-24 V Optocoupler
2	Input2	5-24 V Optocoupler
3	Input3	5-24 V Optocoupler
4	Input4	5-24 V Optocoupler
5	Input5	5-24 V Optocoupler
6	Input6	5-24 V Optocoupler
7	Com	Signal GND
8	Output1	Open-Collector
9	Output2	Open-Collector
10	Output3	Open-Collector
11	Analog In	-10 V ... +10 V
12	GND	Power & Analogue GND

Connection diagram inputs and outputs (I/O) (X1)

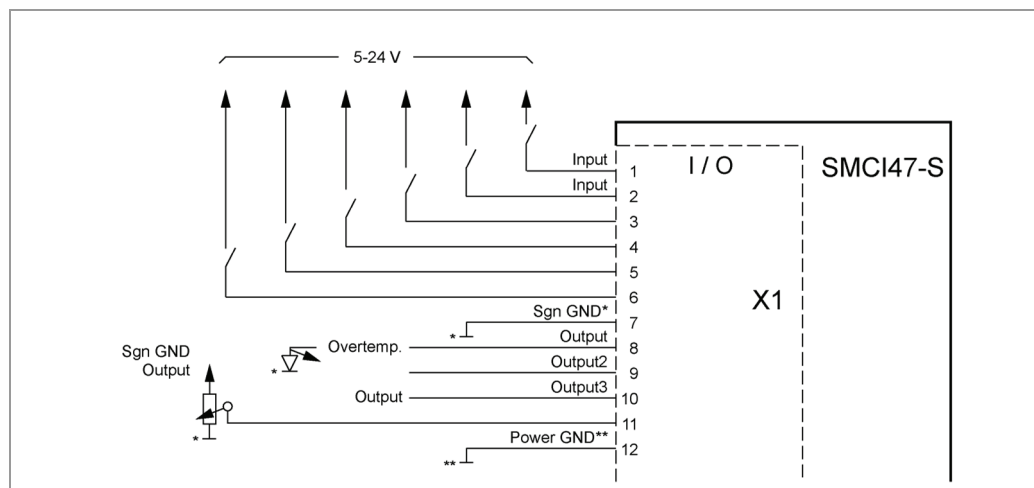

Note:

Com and GND connection are not connected. Com is the ground connection for the inputs and GND is the ground connection for outputs and the internal circuitry.

Function of the inputs

All digital inputs – with the exception of the "Clock" input in the clock directional mode – can be freely programmed (e.g. as a limit switch, enable, etc.) using the NanoPro software (SMCI47-S-2) and can be used for sequential control with NanoJ.

All inputs can be configured for "active-high" (PNP) or "active-low" (NPN) with NanoPro.

Input circuits

All inputs (apart from the "Analogue In" input) are electrically isolated by optocouplers from the voltage supply of the SMCI47-S and designed for 5-24 V input signals at an input current of 10 mA.

Note:

The voltage must not exceed 24 V. It should drop below 2 V for safe switching off and be at least 4.5 V for safe switching on.

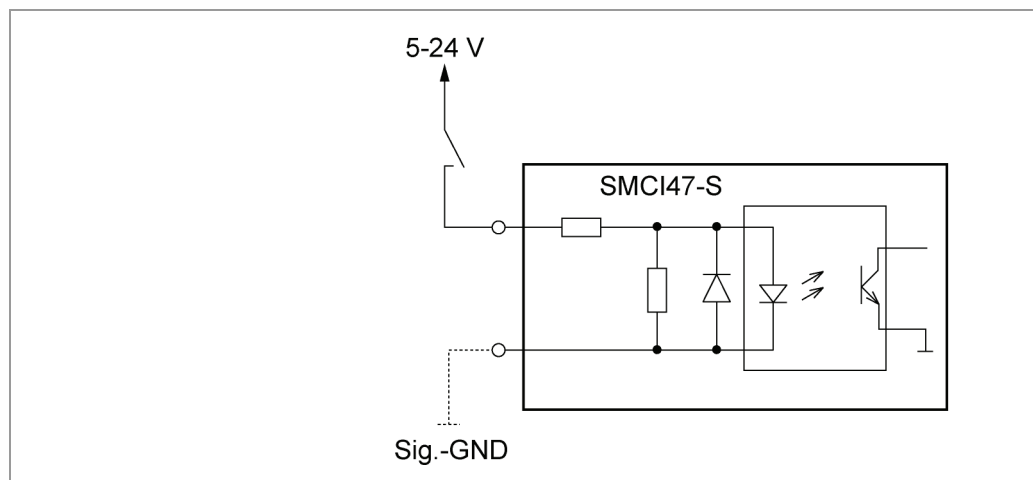

Output circuits

The outputs are MosFET outputs in an Open-Drain circuit (0 switching, max. 30 V / 2 A). An LED can be integrated to test the output. The LED lights up when the output is active.

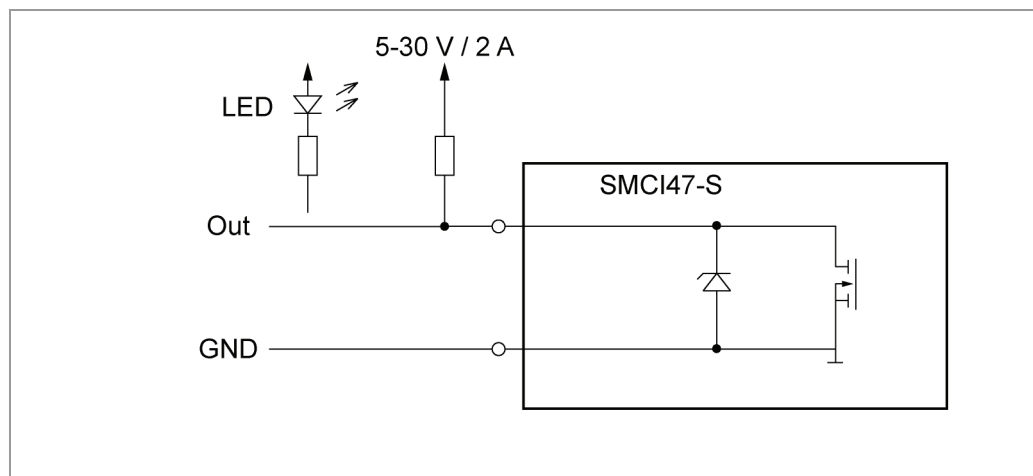

3.2 Brake connection: Connector X2

Function

The connector X2 is used to connect an external safety brake for the motor. This allows the holding torque and therefore the system stiffness to be increased further when necessary.

Parameter

The brake parameters can be configured on the "Motor Settings" tab; see the separate manual on NanoPro.

Pin assignment connector X2

Pin no.	Name	Observations
1	+24 V	
2	GND	

3.3 Encoder connection: Connector X3

Optional encoder

An optional encoder can be connected to the stepper motor control.

By default, the closed-loop control for a three-channel encoder is set up with 500 pulses/revolution in a 1.8° stepper motor. With an 0.9° stepper motor, you should use an encoder with 1000 pulses/revolution to achieve the same control quality.

Depending on the application, it may make sense to use higher encoder resolutions (up to max. 2000 pulses/revolution) to improve control quality or to use a lower resolution (min. 200 pulses/revolution) for low-cost applications or for step monitoring alone.

The following encoder resolutions can normally be processed by the controller: 192, 200, 256, 400, 500, 512, 1000, 1024, 2000, 2048.

Recommended:

Where possible, use Nanotec encoders with the order number WEDS/WEDL-5541 Xxx.

If an encoder is **not** used, the "Disable" mode must be set in the <Error correction> tab in the "Rotation Direction Mode" selection menu. See the NanoPro separate manual.

Using encoders with line drivers

The encoders of the WEDL series with a line driver output an inverted signal in addition to the encoder signal; this leads to better interference immunity and is especially recommended for long lines lengths.

We recommend shielding and twisting the encoder line to minimize interference with the encoder signal from the outside. To be able to connect negative signals to the SMCI47-S, you require adapter ZK-SMCI-LD.

Encoder connection diagram (X3)

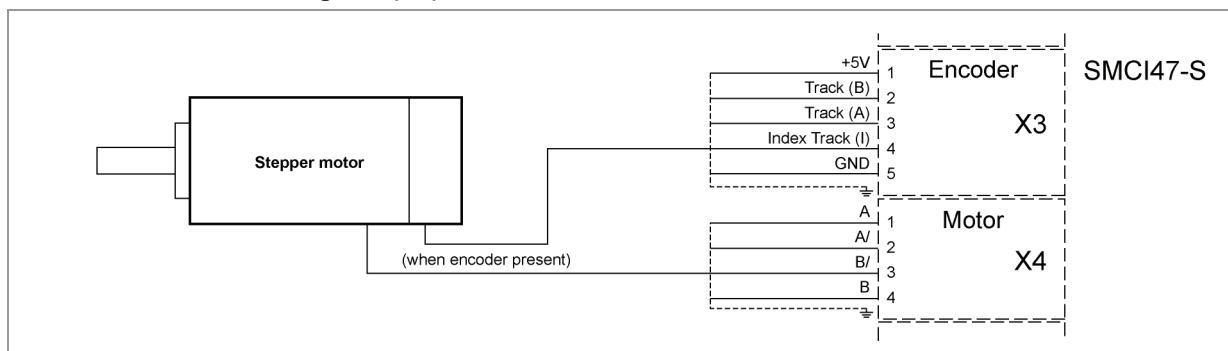

Note:
Complete connection diagram, see Section 2.1.

Pin assignment connector X3: Encoder

Pin no.	Name	Observations
1	+5 V	
2	Track (B)	
3	Track (A)	
4	Index track (I)	
5	GND	

3.4 Stepper motor connection: Connector X4

General information

The motor is connected to the SMCI47-S with a 4-wire cable. Twisted wire pair cables with braided shields are recommended.

	<p>Danger of electrical surges</p> <p>Mixing up the connections can destroy the output stage! See the data sheet of the connected stepper motor.</p> <p>Never disconnect the motor when operating voltage is applied!</p> <p>Never disconnect lines when live!</p>
---	--

Connection diagram

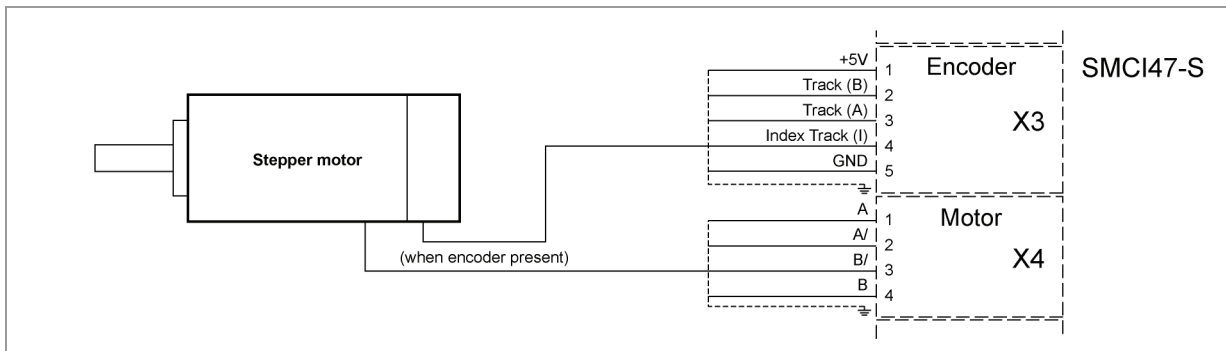

Note:
Complete connection diagram, see Section 2.1.

Pin assignment

Pin no.	Name	Observations
1	A	See the data sheet of the connected stepper motor.
2	A/	
3	B/	
4	B	

Motor with 6 or 8 connections

If you are using a motor with 6 or 8 connections, you need to connect the windings.

The pin configuration for the motor can be found on the motor data sheet, which can be downloaded from www.nanotec.com.

3.5 Voltage supply connection: Connector X5

Permissible operating voltage

The permissible operating voltage for the SMC147-S stepper motor control lies between +24 and +48 V DC; it must not exceed 50 V or fall below 21 V.

A charging condenser with minimum 4700 µF (10000 µF) must be provided for the operating voltage to prevent exceeding the permissible operating voltage (e.g. during braking).

	<p>Danger of electrical surges</p> <p>Connect charging condenser with minimum 4700 µF! Connect a condenser with 10000 µF for motors with flange size 86x86 (series ST8918) or greater!</p> <p>An operating voltage > 50 V will destroy the output stage! Mixing up the connections can destroy the output stage! Never disconnect the motor when operating voltage is applied! Never disconnect lines when live!</p>
---	---

Connection diagram

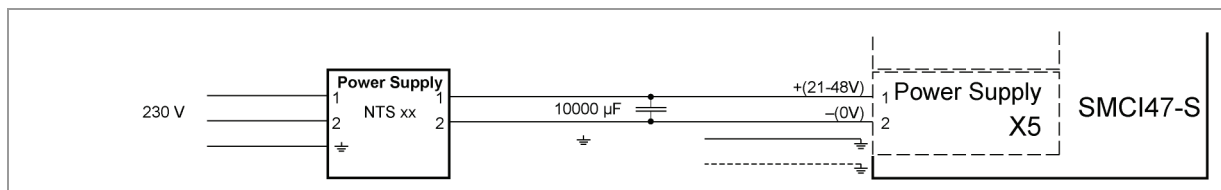

Note:

Complete connection diagram, see Section 2.1.

Pin assignment

Pin no.	Name	Observations
1	Vcc	Operating voltage +24 V DC ... +48 V DC
2	GND	Earth (0 V)

Accessories for voltage supply

Appropriate power packs and charging condensers are available as accessories:

Name	Order identifier
Power pack	NTS-xxV-yA (xx=voltage: 24 or 48 V, y=current: 2.5, 5 or 10 A) Information on the selection of the required power supply unit can be found in our FAQ on www.nanotec.com .
Charging condenser	Z-K4700 or Z-K10000

Note:

Further information about accessories can be found on the Nanotec website www.nanotec.com.

3.6 RS485 network/CANopen: Connector X6

SMCI47-S in a network

Up to 254 (RS485) or 127 (CANopen) stepper motor controls can be controlled in a network from a PC or PLC.

These network connections are set up via the RS485/CANopen interface.

Pin assignment connector X6: RS485 interface

Pin no.	Name	Observations
1	NC	Not assigned
2	Rx+	RS485 Rx+
3	+5 V	Output +5 V
4	Tx+	RS485 Tx+
5	NC	
6	NC	
7	Rx-	RS485 Rx-
8	GND	Output GND (0 V)
9	Tx-	RS485 Tx-

Pin assignment connector X6: CANopen interface

Pin no.	Name	Observations
1	NC	
2	CAN-	CAN low
3	CAN Ground	Internally connected with pin 6
4	NC	
5	Shield	
6	CAN Ground	Internally connected with pin 3
7	CAN+	CAN high
8	NC	
9	Vcc	Supply up to 30 V. Used for safety feature.

CANopen (SMCI47-S-3)

With the SMCI47-S, it is also possible to control the motor via CANopen.

If you use the control with CANopen you can use the additional safety function of the separate logic supply: Even when the voltage supply of the SMCI47-S is interrupted, the processor continues to be supplied with power via the communication line and the position data cannot be lost so that the machine does not need to be referenced after being switched on.

More detailed information on this can be found in the CANopen reference and in the NanoCAN user manual.

CANopen connection

A suitable CAN interface adapter (e.g. USB adapter from IXXAT or PEAK) is required for connecting with a PC.

CANopen standard connector assignment (on the adapter)

Pin no.	Name
2	CAN low
3	CAN GND
7	CAN high

CANopen connection assignments on the controller

Circuits according to the CANopen standard connector assignment, see preceding table.

Notes on the baud rate

It is important to note that both the controller and the CAN master use the same baud rate. Only this way can communication be established.

The baud rate has a direct influence on the maximum possible bus length. The following list shows the possible baud rates as well as their maximum permissible bus lengths:

Baud rate	Bus length
1 MBaud	40 m
500 kBaud	130 m
250 kBaud	270 m
125 kBaud	530 m
50 kBaud	1300 m
20 kBaud	3300 m

Notes on the bus termination

With CAN, the bus termination is handled by two 120 Ohm resistors on both ends of the bus.

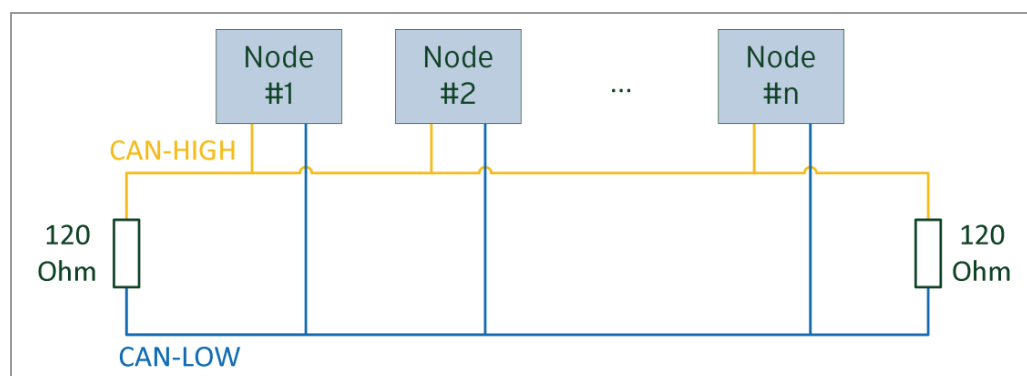

Circuit diagram RS485 network

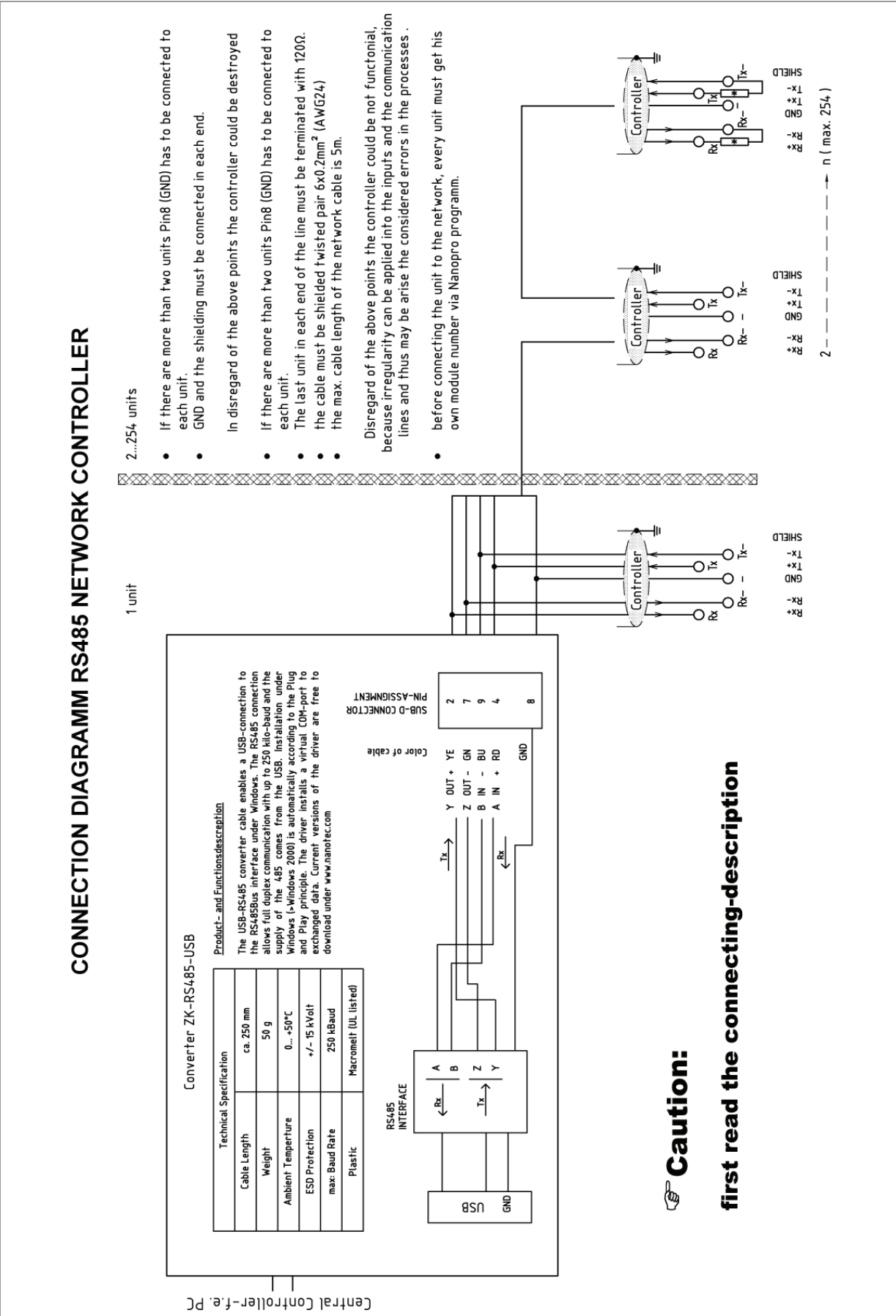

Two-wire operation RS485

To enable RS485 two-wire transmission capability, all bus stations must have a direction control.

An intelligent converter, which automatically switches to transmission mode when a start bit is received at the RS232 interface and returns to reception mode at the end of the stop bit, enables two-wire operation of the SMC147-S. This solution requires no software support.

We can recommend the ICP-7520 converter, for example, that is available from Schuricht.

Talk to our Technical Hotline if you require support for this.

Setting the RS485 module address

Hardware setting

The RS485 module address can be set by hardware via two HEX coded switches on the printed circuit board.

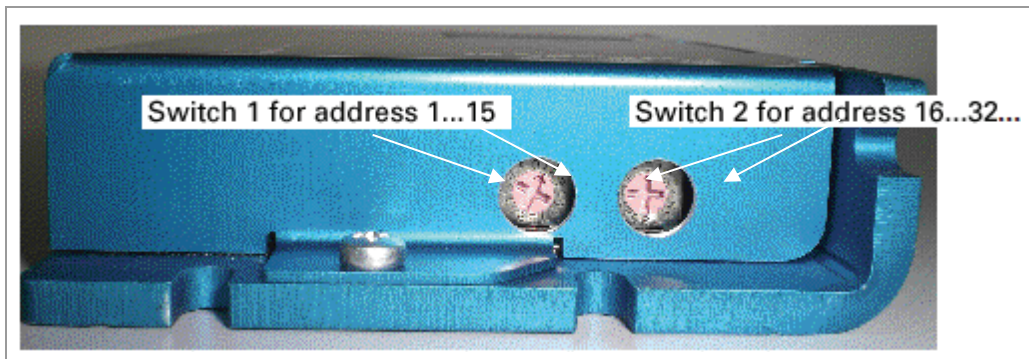

The 1st digit is set with switch 1 (left), the 16th digit of the address is set with switch 2 (right).

Module address	Switch 1 (left)	Switch 2 (right)
Software setting	0	0
1	1	0
2	2	0
...
15	F	0
16	0	1
17	1	1
...
32	0	2
...
64	0	3
...
80	0	5
...
96	0	6
...
112	0	7
...
255	F	F

Setting the CANopen module address

There are two basic ways of setting the CANopen node ID and the baud rate:

- Hardware setting: Via rotary switches on the control
- Software setting: With NanoCAN, see separate manual for NanoCAN.

To be able to make a software setting with NanoCAN, a certain value must be set on the rotary switches of the control; see the following table:

Rotary switch value dec (hex)	Node ID	Baud rate
0 (0x00)	From EEPROM	= 1 MBaud
1 - 127 (0x01 - 0x7F)	= rotary switch value	
128 (0x80)	From EEPROM	From EEPROM
129 - 255 (0x81 - 0xFF)	= rotary switch value minus 128	

Note:

The rotary switches must be set to the desired value before the control is switched on since this value is only read in when the control is restarted.

The rotary switches can be used to set a two-digit hexadecimal number (0x00 to 0xFF):

- Right-hand rotary switch: 16's place (e.g. 0xF0)
- Left-hand rotary switch: 1's place (e.g. 0x0F)

Example 1:

If the right-hand rotary switch is set to 2 and the left-hand rotary switch is set to 1 (0x21), this results in a number equivalent to the decimal number 33 (= 2*16 + 1*1).

In this case, the node ID is set to 33 on the hardware. The baud rate is set to 1 MBaud.

Example 2:

If the right-hand rotary switch is set to 8 and the left-hand rotary switch is set to 0 (0x80), this results in a number that is equivalent to the decimal number 128 (= 8*16 + 0*1).

In this case, the node ID and baud rate are read out of the EEPROM.

4 Operating modes

4.1 Serial operating modes (SMCI47-S-2)

Introduction

Depending on the travel profile, the motor can be operated using different operating modes. Due to the great capacity and functions available, it offers designers and developers a rapid and simple method of resolving numerous drive requirements with less programming effort.

Select the required operating mode for each drive profile and configure the controller according to your requirements.

More detailed information can be found in the separate NanoPro manual.

Overview of operating modes and their areas of application

Operation mode	Application
Relative positioning	Use this mode when you wish to travel to a specific position. The motor travels according to a specified drive profile from a Position A to a Position B.
Absolute positioning	
Internal reference run	During the internal reference run, the motor travels to an internal reference point at the set minimum speed (index mark of encoder, only in combination with an encoder).
External reference run	During an external reference run, the motor travels to a switch connected to the reference input.
Speed mode	Use this mode when you wish to travel with a specific speed (e.g. a conveyor belt or pump speed). In the speed mode, the motor accelerates with a specified ramp from the starting speed (start frequency "V Start") to the specified maximum speed (maximum frequency "V Normal"). Several inputs enable the speed to be changed on-the-fly to different speeds.
Flag positioning mode	The flag positioning mode offers a combination of the speed and positioning modes. The motor is initially operated in speed mode; when a trigger point is reached, it changes to the positioning mode and the specified setpoint position (relative to the trigger position) is approached. This operating mode is used for labeling, for example: the motor first travels with the set ramp to the synchronous speed of the conveyed goods. When the labels are detected, the preset distance (position) is traveled to apply the labels.

Operation mode	Application
Clock direction mode, left	Use this mode when you wish to operate the motor with a superordinate controller (e.g. CNC controller). In the clock direction mode, the motor is operated via two inputs with a clock and a direction signal from a superordinate positioning control (indexer). Depending on the mode selected (Int. Ref./Ext. Ref.), the internal and external reference runs are supported.
Clock direction mode, right	
Clock direction mode Int. Ref.	
Clock direction mode Ext. Ref.	
Analog and joystick mode	The motor is controlled in this operating mode simply with a potentiometer or a joystick (–10 V to +10 V). Use this mode if you want to use the motor in a simple application: <ul style="list-style-type: none"> • Setting a specific speed, e.g. via an external potentiometer, • Traveling synchronously with a superordinate controller with analog output (–10 V to +10 V).
Analogue positioning mode	Use this mode when you wish to travel to a specific position. The voltage level on the analog input is proportional to the required position.
Torque mode	Use this mode when you require a specific output torque independent of the speed as is the case in typical winding and unwinding applications. The maximum torque is specified via the analog input.

Selecting the operating mode in NanoPro

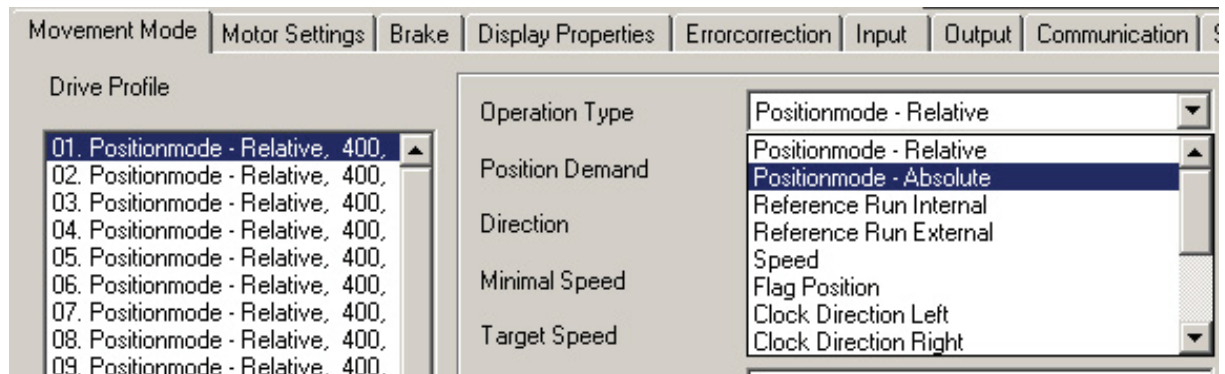

4.2 CANopen operating modes (SMCI47-S-3)

Introduction

The motor can be operated using a total of 5 different operating modes in CANopen mode.

More detailed information can be found in the separate NanoCAN manual.

Overview of operating modes and their areas of application

Operation mode	Application
Positioning Mode (PP Mode)	Use this mode if you want to use the motor for positioning. The motor moves from A to B with the set parameters (ramp, speed, etc.).
Speed Mode (Velocity Mode)	Use this mode when you wish to travel with a specific speed (e.g. a conveyor belt).
Reference run (Ref. Mode/Homing Mode)	Use this mode to reference the motor (internal/external/on block).
Interpolated Position Mode	Use this mode with a superordinate path control.
Torque Mode	Use this mode to specify a defined torque.

Selecting the operating mode in NanoCAN

In the <Drive Modes> tab the operating mode can be selected. When the tab is activated, the corresponding SDO is immediately written to the controller to activate the (possibly previously) selected operating mode.

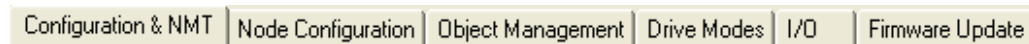

5 Troubleshooting

Troubleshooting procedure

Proceed with care during troubleshooting and error rectification to avoid damaging the controller.

	<p>Danger of electrical surges</p> <p>An operating voltage > 50 V and incorrect connections can destroy the end stage. Never disconnect the motor when operating voltage is applied! Never disconnect lines when live!</p>
---	--

Possible errors in RS485 mode (SMCI47-S-2)

Error	Possible cause	Rectification
Controller is not ready	Data transmission to SMCI47-S not possible (communication error): Incorrect COM port selected.	In the <Communication> tab, select the PC port to which you have connected the SMCI47-S (e.g. "COM-1"). The port used can be found in the device manager of your PC.
	The communication cable is not connected or is interrupted.	Use only the recommended converter from Nanotec: <ul style="list-style-type: none"> • ZK-RS485-RS232 • ZK-RS485-USB
	A non-existent motor number (module number) is set.	Set the correct module address. See the separate manual on NanoPro.
	The power supply of the SMCI47-S is interrupted.	Check voltage supply, switch on if necessary.
	Another open program is blocking the COM port to which the SMCI47-S is connected.	Close down other programs on your PC.
	Inadmissible data was sent to the controller during the output of a travel profile.	Click on the <Yes> button to stop the travel profile. The SMCI47-S switches back to the "Ready" state. The data can then be resent to the controller.
Transmission error	Data transmission to the SMCI47-S is disturbed (sender or receiver are disturbed).	Check that the motor connection is correctly wired. We recommend using the following Nanotec converters: <ul style="list-style-type: none"> • ZK-RS485-RS232 • ZK-RS485-USB
Position error	The motor cannot reach the position or the limit switch was overrun.	Click the <Yes> button in the error message; the error is reset.
Red LED on the SMCI47-S lit up.	Overtemperature of power electronics > 75 °C	Switch off controller and allow to cool. The error is reset when the SMCI47-S is disconnected from the power supply unit.
	Undervoltage	Check voltage supply.

Possible errors in CANopen mode (SMCI47-S-3)

Error	Possible cause	Rectification
No communication with the controller	The wrong node ID has been set.	On the <Configuration & NMT> tab in NanoCAN, select the node ID that is set on the rotary switches of the controller.
	The power supply is interrupted.	Check voltage supply, switch on if necessary.
	The communication cable is not connected or is interrupted.	Check all connections, especially the terminal resistances.
	CAN bus incorrectly terminated with 120 Ohm.	Ideally, terminate the bus on both ends with 120 Ohm.
Transmission error	Data transmission is disturbed (sporadically).	Switch the power supply off and on again.
The red LED on the controller flashes rapidly	Internal error.	Disconnect the controller briefly from the power supply.
The red LED on the controller flashes slowly.	Firmware update error.	Load the firmware with NanoCAN again.

6 Technical data

Electrical connections

Operating voltage V_b	DC 24 V to 48V \pm 4%
Max. phase current	Adjustable up to max. 10.5 A/phase Continuous current 7 A/phase
Current drop	Adjustable 0 to 100% of rated current
Interfaces	SMCI47-S-2: RS485 (4-wire) <ul style="list-style-type: none"> • 115200 bps (adjustable) • 1 start bit, 8 data bits, 1 stop bit • No parity SMCI47-S-3: CAN bus (CANopen) <ul style="list-style-type: none"> • Extended functionality • Brake output • Separate circuit for supply and processor • Closed-Loop capable

Controller parameters

Step resolution	Full Step Half Step Quarter Step Fifth Step Eighth Step Tenth Step 16th step 32nd Step 64th Step Adaptive microstep (1/128)
Step frequency	0 to 50 kHz in clock direction mode 0 to 25 kHz in all other modes
Position monitoring	Automatic error correction up to 0.9°

Inputs and outputs

Inputs	6 optocouplers 5 – 24 V <ul style="list-style-type: none"> • Safe switch off: max. 2 V • Safe switch on: min. 4.5 V Signal delay time: <ul style="list-style-type: none"> • Inputs 1 to 5: 120 μs • Input 6: 10 μs
Outputs	3 MosFET outputs <ul style="list-style-type: none"> • Open-Drain (0 switching, max. 30 V/2 A) • Signal delay time: output 1/2: \approx 12 μs (with 10 kΩ-Pull-Up at 24 V) 1 brake output

Protective circuits

Overvoltage and undervoltage	Protective circuit for voltages > 50 V or < 21 V
Max. heat sink temperature	Approx. 67 °C
Max. ambient temperature	0 to 40 °C

SMCI47-S dimensions

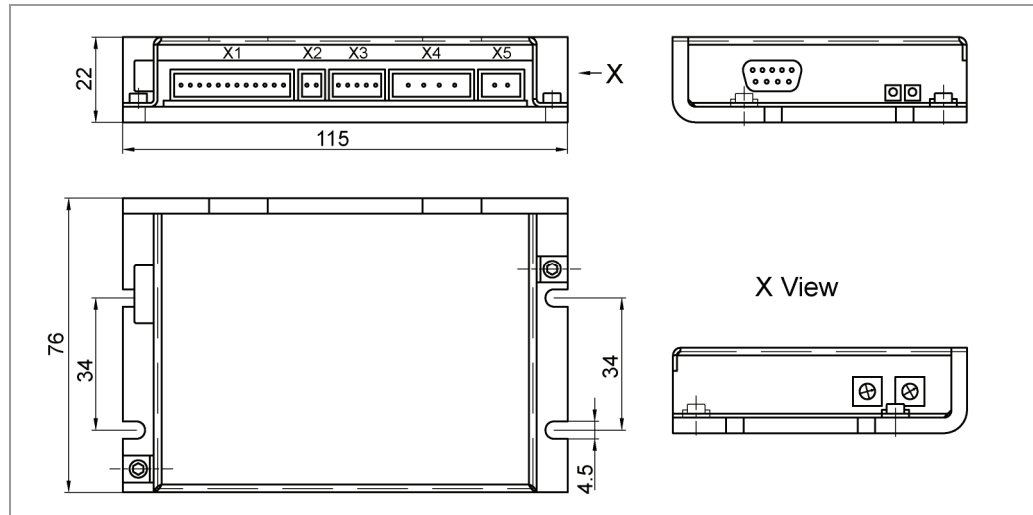

A complete set of datasheets is available for downloading at www.nanotec.com.

Connectors

The following connectors are available on the SMCI47-S:

- Connectors X1, X3:
Phoenix connector, Type MICRO COMBICON
- Connectors X4, X5:
Phoenix connector, Type COMBICON-HC
- Connector X6:
Sub-D 9-pin (RS485 or CAN)

Index

A

Accessories for voltage supply 16

B

Brake 13

C

CANopen 6, 10, 17

Closed-Loop current control 5

Commissioning 8

Connection diagram inputs and outputs (I/O) 11

Connection diagram stepper motor 15

Connection diagram voltage supply 16

Connector X1 11

Connector X2 13

Connector X3 14

Connector X4 15

Connector X5 16

Connector X6 17

E

Encoder 6, 14

Encoder connection diagram 14

F

Firmware 5

Functions 5

I

Input circuits 12

Inputs and outputs (I/O) 11

N

NanoJ 6

O

Operating mode

 CANopen 24

Operating modes

 serial 22

Operating voltage 16

Output circuits 12

P

Pin assignment

 connector X1 11

 connector X2 13

Pin assignment connector X3 14

Pin assignment connector X4 15

Pin assignment connector X5 16

Pin assignment connector X6 17

Protective circuits 28

R

Rotation monitoring 6

RS485 network 17

S

Stepper motor 15

T

Two-wire operation 20

V

Voltage supply 16