

Technical Manual



Stepper motor control **SMCP33**

NANOTEC ELECTRONIC GmbH & Co. KG
Gewerbstraße 11
D-85652 Landsham near Munich, Germany

Tel. +49 (0)89-900 686-0
Fax +49 (0)89-900 686-50
info@nanotec.de

Editorial

© 2010

Nanotec® Electronic GmbH & Co. KG

Gewerbestraße 11

D-85652 Landsham / Pliening, Germany

Tel.: +49 (0)89-900 686-0

Fax: +49 (0)89-900 686-50

Internet: www.nanotec.com

All rights reserved!

MS-Windows 2000/XP/Vista are registered trademarks of Microsoft Corporation.

Version/Change overview

Version	Date	Changes
1.0	2009-11-23	New issue C+P
1.1	2010-02-01	Technical data / Inputs
1.2	2010-02-10	Pin assignment

About this manual

Target group

This technical manual is aimed at designers and developers who need to operate a Nanotec stepper motor without much experience in stepper motor technology.

Important information

This technical manual must be carefully read before installation and commissioning of the controller.



Nanotec[®] reserves the right to make technical alterations and further develop hardware and software in the interests of its customers to improve the function of this product without prior notice.

The manual was created with due diligence. It is exclusively intended as a technical description of the product and as commissioning instructions. The warranty is exclusively for repair or replacement of defective equipment, according to our general terms and conditions, liability for subsequent damage or errors is excluded. Applicable standards and regulations must be complied with during installation of the device.

For criticisms, proposals and suggestions for improvement, please contact the above address or send an email to: info@nanotec.de

Additional manuals

Please also note the following manuals from Nanotec:

<p>NanoPro User Manual</p>	<p>Configuration of controllers with the NanoPro software</p>	
<p>Programming manual</p>	<p>Controller programming</p> <ul style="list-style-type: none"> • Command reference • NanoJ • COM interface 	

The manuals are available for download on www.nanotec.com.

Contents

1	Overview	5
2	Commissioning	7
3	Connections and circuits	9
3.1	Pin assignment SMCP33	9
3.2	SMCP33-EVA evaluation board.....	11
3.3	Inputs and outputs (I/O)	13
3.4	Brake connection	15
3.5	Ballast connection	15
3.6	Encoder connection	16
3.7	Stepper motor connection.....	17
3.8	Power supply connection	19
3.9	RS485 communication.....	20
4	Operating modes.....	21
5	Troubleshooting.....	23
6	Technical data	24
	Index.....	26

1 Overview

Introduction

The SMCP33 stepper motor control is an extremely compact and cost-effective constant current final output stage with integrated closed-loop current control.

Due to the great capacity and functions available, it offers designers and developers a rapid and simple method of resolving numerous drive requirements with less programming effort.

It is used for controlling standard stepper motors (including with attached encoders) or motors with integrated encoders or brakes.

The plug-in module can be integrated in complex device control systems with a minimum of additional development effort, especially for the direct and virtually noise-free and resonance-free control of the output stages via the microcontroller by means of the dspDrive® method – both in open-loop and closed-loop operation.

In conjunction with the integrated NanoJ programming language based on the Java standard, complete sequencing programs can be implemented on the plug-in module that can be run autonomously without a superordinate controller.

Variants

The SMCP33 is available in the following variants:

- SMCP33: 2 A phase current
- SMCP33-K: with a heat sink for 4 A phase current

Functions of the SMCP33

The SMCP33 stepper motor control contains the following functions:

- Microstep 1/1 – 1/64 final output stage (0.014° step resolution)
- Closed-loop current control (sinusoidal commutation via the encoder)
- Powerful DSP microprocessor for flexible I/O
- Sequence programs with NanoJ
- Rotation monitoring for optional encoder
- RS485 port for parameterisation and control
- Network capability with up to 255 controllers
- The function of the 16 digital inputs and outputs and the two analogue inputs is freely configurable
- Easy programming with the NanoPro Windows software



Closed-loop current control (sinusoidal commutation via the encoder):

In contrast to conventional stepper motor controls where only the motor is actuated or the position adjusted via the encoder, sinusoidal commutation controls the stator magnetic field as in a servomotor via the rotary encoder. The stepper motor acts in this operating mode as nothing more than a high pole servomotor, i.e. the classic stepper motor noises and resonances vanish. As the current is controlled, the motor can no longer lose any steps up to its maximum torque.

If the controller recognises that the rotor is falling behind the stator field due to overload, adjustments are made with optimal field angle and increased current. In the opposite case, i.e. if the rotor is running forward due to the torque, the current is automatically reduced so that current consumption and heat development in the motor and controller are much lower compared to normal controlled operation.

dspDrive[®]

With dspDrive[®], the motor current is controlled directly by a digital signal processor. Unlike conventional ICs, which resolve the winding current measurement and the target current value with only 6 or 8 bit, the new dspDrive[®] performs the entire control with a resolution of 12 bit. The parameters of the PI current controller can be adjusted to the motor and by the user as a function of the rpm.

This has the following application advantages:

- Very smooth, low-resonance operation with a sinusoidal current in the windings.
- Very good step angle accuracy and synchronisation, even in open-loop operation.
- Three-phase stepper motors and BLDC motors can be controlled as well.

NanoJ

With the integrated NanoJ programming language based on the Java standard, complete sequencing programs can be implemented that can be run autonomously without a superordinate controller.

The programs can be created, compiled directly and written to the controller with the free NanoJEasy editor.

More detailed information can be found in the separate programming manual.

Settings

The operating behavior of the motor can be set and optimised according to individual requirements by setting the motor-related parameters. The parameters can be set using the NanoPro software and significantly reduce commissioning time.

More detailed information on this can be found in the separate NanoPro user manual.

Rotation monitoring

Even if stepper motors do not lose steps during normal operation, the integrated rotation monitoring provides additional security in all operating modes, e.g. against motor stalling or other external sources of error. The monitoring function detects a stalled motor or step loss after half a step at the most (for 1.8° stepper motors).

Automatic error correction is possible after the drive profile is ended or during the drive.

2 Commissioning

Provisions

Commissioning of the SMCP33 stepper motor is described below.

You will find the main "First Steps" here to start working rapidly with the SMCP33 if you are using the NanoPro software from a PC.

More detailed information can be found in the separate NanoPro manual.



If you want to work at a later time with a PLC or your own program, you will find the necessary information in the separate "Programming manual".

Familiarise yourself with the SMCP33 stepper motor control and the corresponding NanoPro control software before you configure the controller for your application.

Procedure

Proceed as follows to commission the controller:

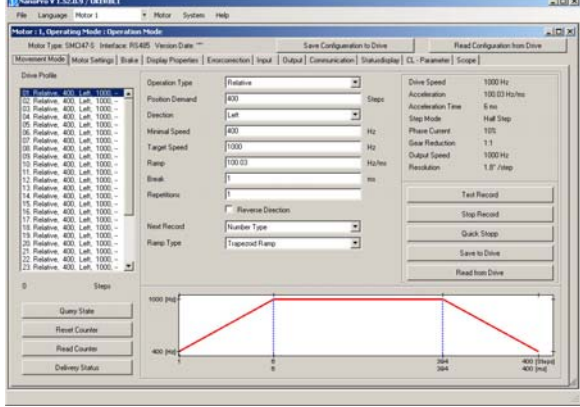
Step	Action	Note
1	Install the NanoPro control software on your PC. See the separate manual on NanoPro.	Download of www.nanotec.com
2	Plug the SMCP33 into the motherboard (SMCP33-EVA evaluation board).	Detailed information on the SMCP33-EVA can be found in Section 3.2 SMCP33-EVA evaluation board and under the Accessories/Electronics menu item on www.nanotec.com
3	Connect the controller to the stepper motor.	Detailed information on connections can be found in Chapter 3 „Connections and circuits“.
4	Switch on the operating voltage (12 V DC ... 48 V DC).	
5	Connect the controller with your PC via the serial D-Sub 9 or the USB port of the SMCP33-EVA motherboard. Use one of the following converter cables for this purpose: <ul style="list-style-type: none"> • ZK-RS485-RS232 for connection to the serial interface • ZK-RS485-USB for connection to the USB interface 	Order number: <ul style="list-style-type: none"> • ZK-RS485-RS232 • ZK-RS485-USB Note: Download the necessary driver from www.nanotec.com under the Accessories/Converter menu item

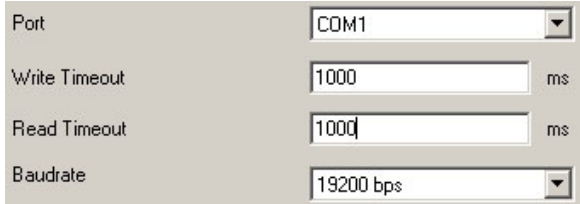
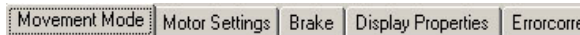
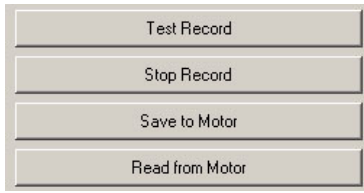
Step	Action	Note
6	<p>Start the NanoPro software.</p> 	The NanoPro main menu appears.
7	<p>Select the <Communication> tab.</p> 	
8	<p>In the "Port" field, select the COM port to which the SMCP33 is connected.</p> 	The number of the COM port to which the controller is connected can be found in the device manager of your Windows PC (System Control/System/Hardware).
9	<p>Select the "115200 bps" entry in the "Baud rate" selection field.</p>	
10	<p>Select the <Mode> tab.</p> 	
11	<p>Click on the <Test Record> button to carry out the pre-set travel profile.</p> 	The connected motor operates with the pre-set travel profile (default travel profile after new installation).
12	<p>You can now enter your required settings. For instance, you can enter a new travel profile.</p>	See the separate manual on NanoPro.

3 Connections and circuits

3.1 Pin assignment SMCP33

Pin assignment

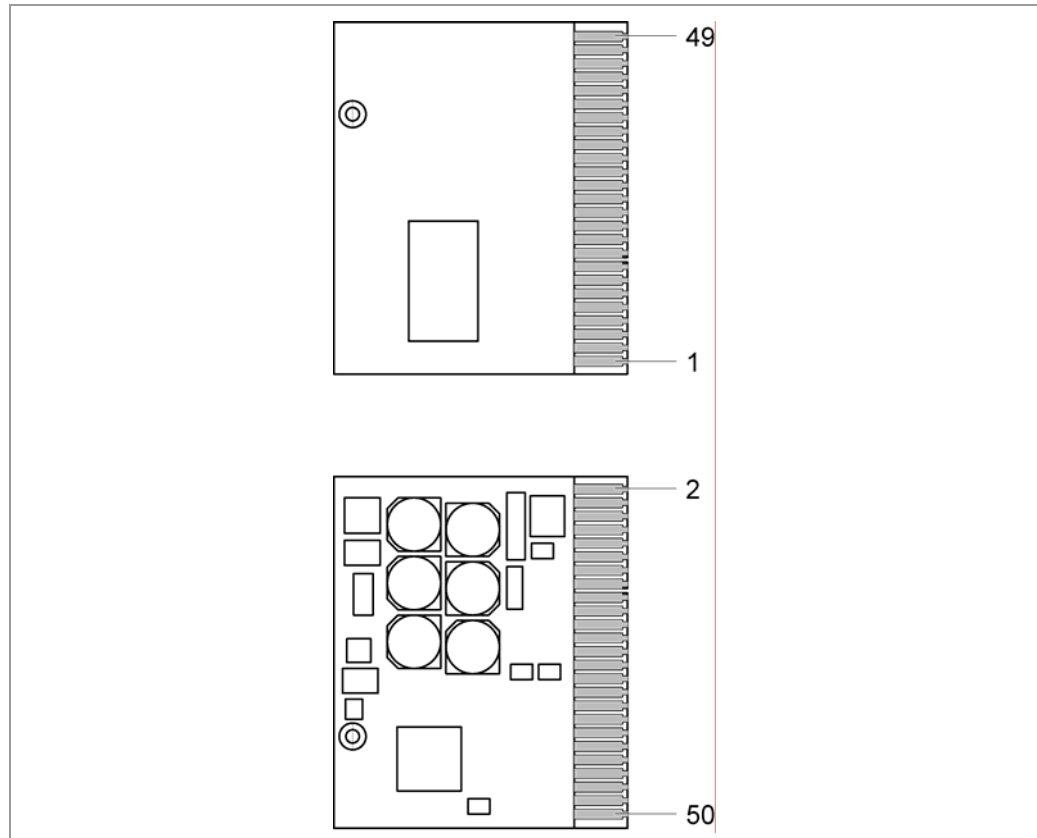

Description

Pin-No.	Name	Observations
1/2	GND	Earth (0 V)
3/4	+VB	Switch on the operating voltage (+12 V DC ... +48 V DC)
5/6	GND	Earth (0 V)
7/8	B/	Motor phases
9/10	B	
11/12	A/	
13/14	A	
15/16	GND	Earth (0 V)
17	Index track (I)	Encoders
18	Track (A)	
19	Track (B)	
20	+5 V	
21	Temp motor	
22	Brake	Brake output
23/24	Ballast	Ballast output
25	RS-485 Rx-	RS-485 connection
26	RS-485 Rx+	
27	RS-485 Tx-	
28	RS-485 Tx+	
29/30	GND	Earth (0 V)
31	Analogue In 1	Analogue input 1 (-10 V ... +10 V)
32	Analogue In 2	Analogue input 2 (-10 V ... +10 V)
33	Input 1	Digital inputs
34	Input 2	
35	Input 3	
36	Input 4	
37	Input 5	
38	Input 6	
39	Input 7	
40	Input 8	
41	Output 1	Output
42	Output 2	
43	Output 3	
44	Output 4	
45	Output 5	
46	Output 6	
47	Output 7	
48	Output 8	
49/50	GND	Earth (0 V)

3.2 SMCP33-EVA evaluation board

General information

The SMCP33-EVA evaluation board of Nanotec is a motherboard for the SMCP33 plug-in device card. It can be used for the rapid commissioning of four stepper motors via a pre-wired RS485 network and a PC connection. All inputs and outputs available in the SMCP33 are led to the outside via Phoenix Combicon connectors. In addition, an encoder or a brake can be connected.

Board

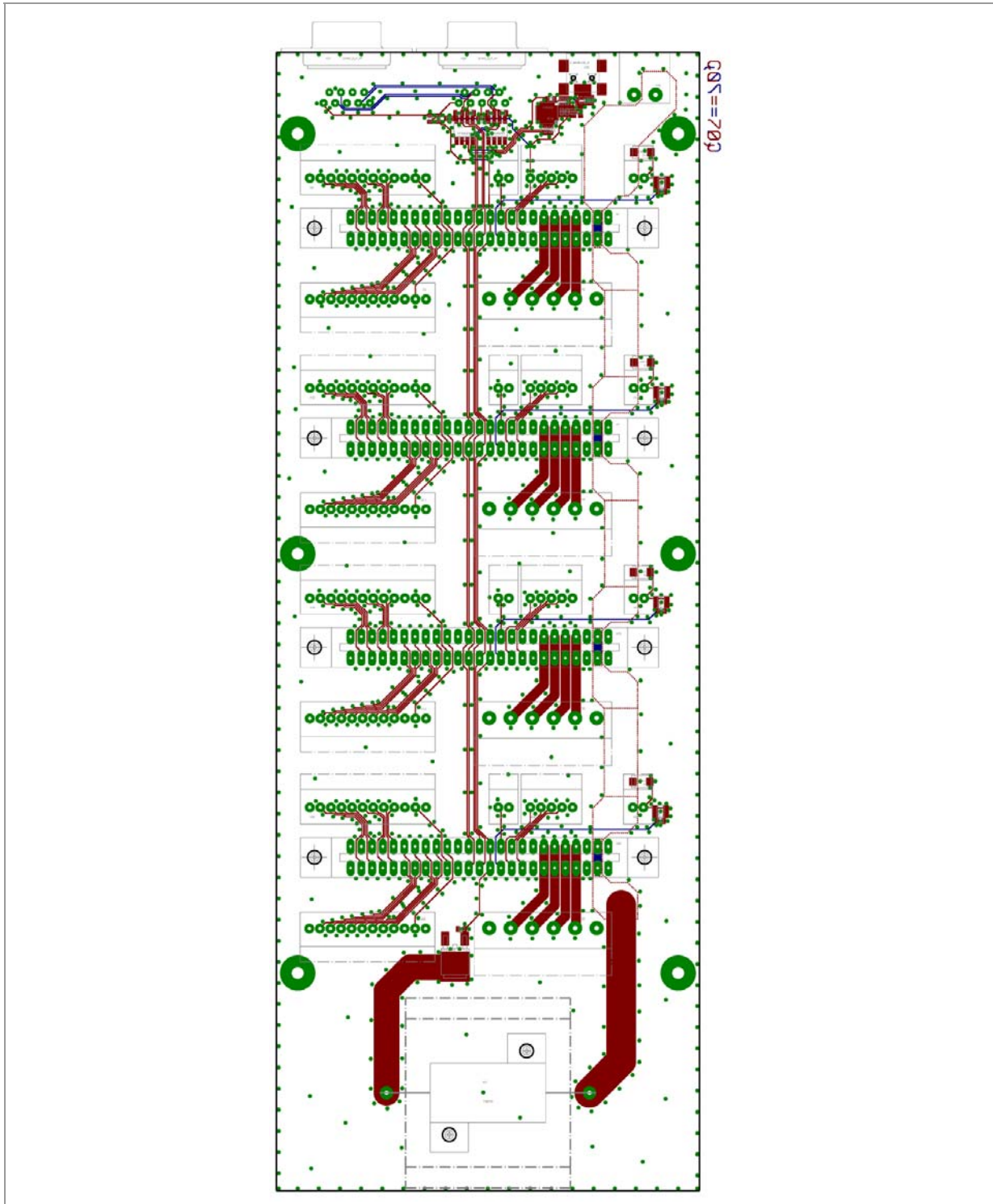

Connection diagram

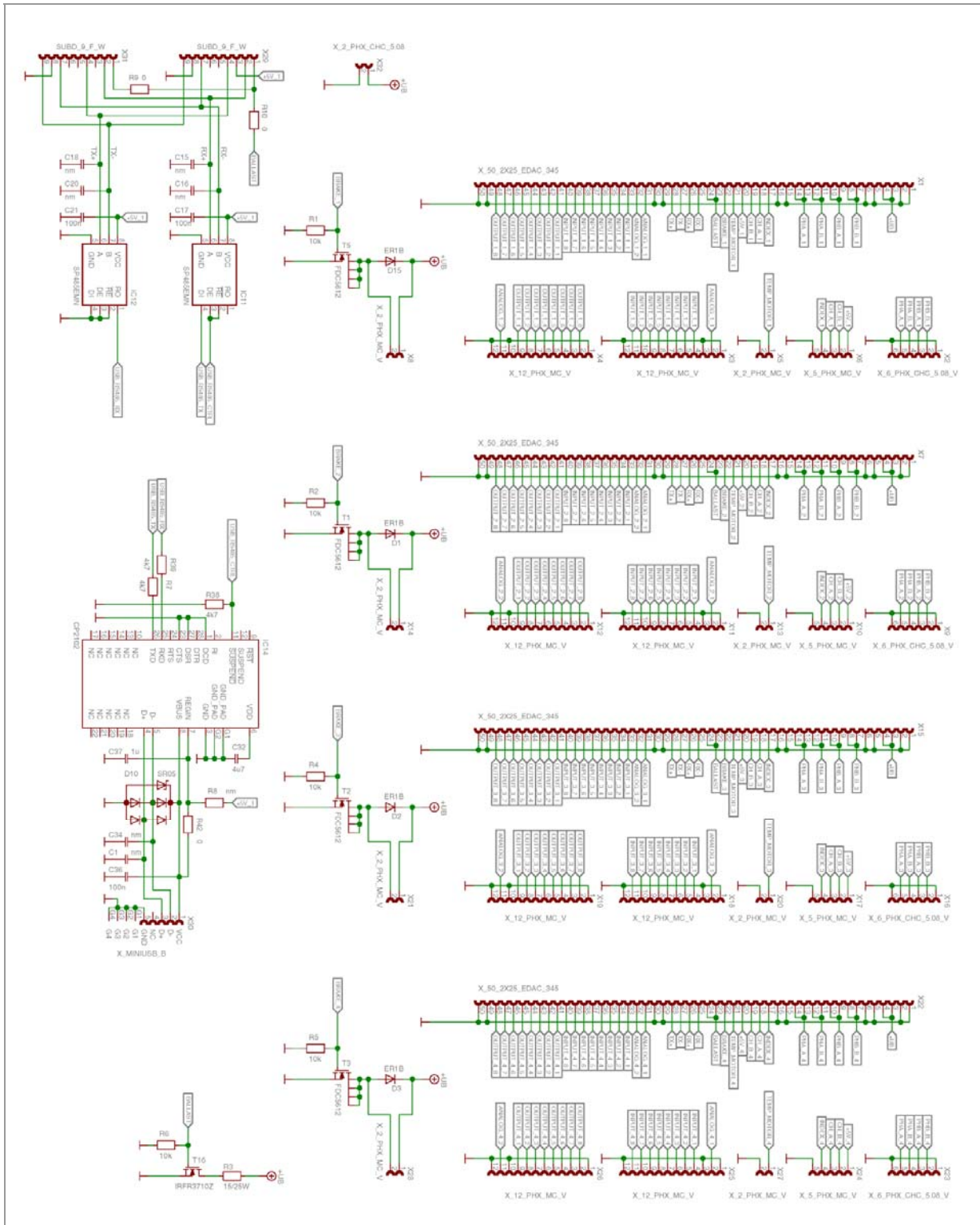

Note:
 The connection diagram is available for download on www.nanotec.de.

3.3 Inputs and outputs (I/O)

Input circuits

All digital inputs are designed for 5 V input signals.

Note:

The voltage should drop below 2 V for safe switching off and be at least 4.5 V for safe switching on.

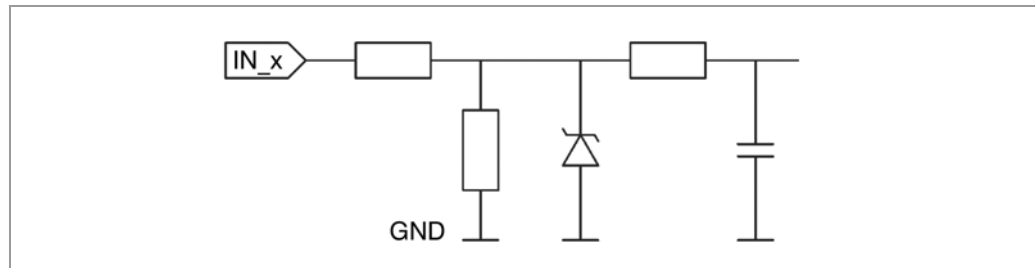

Output circuits

The outputs are a TTL output circuit (5 V / max. 20 mA). To be able to test the output, an LED with a series resistance against earth can be integrated. The LED lights up when the output is active.

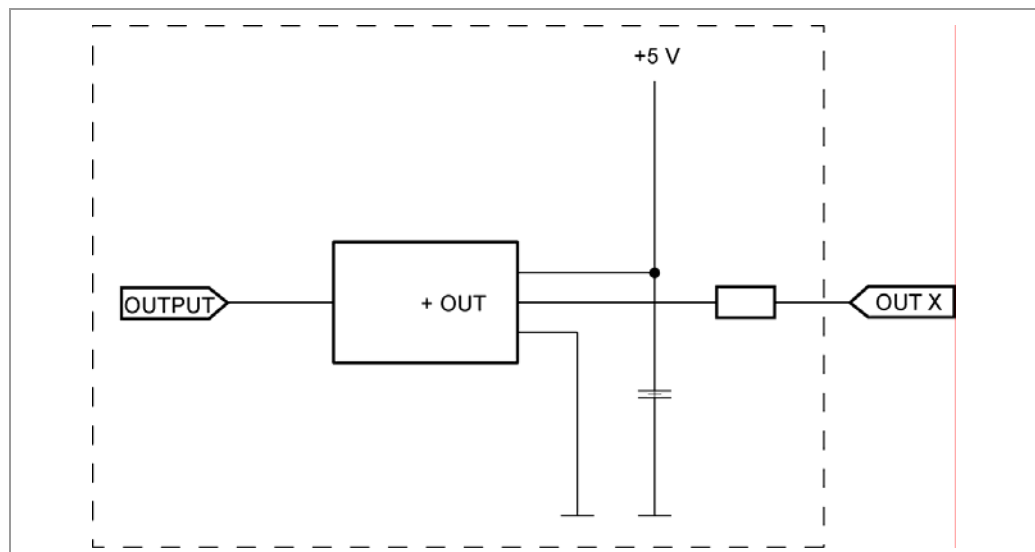

Function of the inputs

The inputs have different functions depending on the operating modes; see the following table

Pin-No.	Name	Operation Type					
		Position	Speed	Flag position	Clock direction	Analogue	Joystick
31	Analogue In 1					Analogue In	Analogue In
32	Analogue In 2						
33	Input 1	Start Reset	Enable	Start	Enable	Enable	Enable
34	Input 2	Drive profile	Speed	Travel profile	Manual mode	Speed	Speed
35	Input 3	Drive profile	Speed	Travel profile	Manual mode	Speed	Speed
36	Input 4	Drive profile	Speed	Travel profile	Ext. limit switch	Speed	Speed
37	Input 5	Travel profile	Speed	Trigger	Direction	Speed	Speed
38	Input 6	Ext. limit switch	Direction	Ext. limit switch	Clock	Direction	
39	Input 7						
40	Input 8						

All digital inputs – with the exception of the "Clock" and "Direction" inputs in the clock directional mode – can be freely programmed using the NanoPro software (e.g. as a limit position switch, enable, etc.) and can be used for sequential control with NanoJ.

The "Analogue In 2" analogue input currently can only be used by the programming language.

All inputs can be configured for "active-high" or "active-low" with NanoPro.

Signal states at the outputs

The following table shows the possible signal states at the outputs 1 to 3:

Signal states			Meaning
Output 3	Output 2	Output 1	
	0	0	Rotation monitoring (error) or limit switch
	0	1	Motor idle (waiting for new command).
	1	0	Busy (control processing last command).
	1	1	Reference point or zero point reached
1			Overtemperature

The outputs can be freely programmed using the NanoPro software.

3.4 Brake connection

Function

The brake output is used to control an external safety brake for the motor. This allows the holding torque and therefore the system stiffness to be increased further when necessary.

Because the output is a TTL output, an additional driver component is needed.

Parameters

In NanoPro, the brake parameters can be configured in the <Brake> tab; see the separate manual on NanoPro.

Example: Connection to SMCP33-EVA

On the SMCP33-EVA motherboard shown in Section 3.2 SMCP33-EVA evaluation board, the brake connections are located on the interfaces X8/ X14/ X21/ X28.

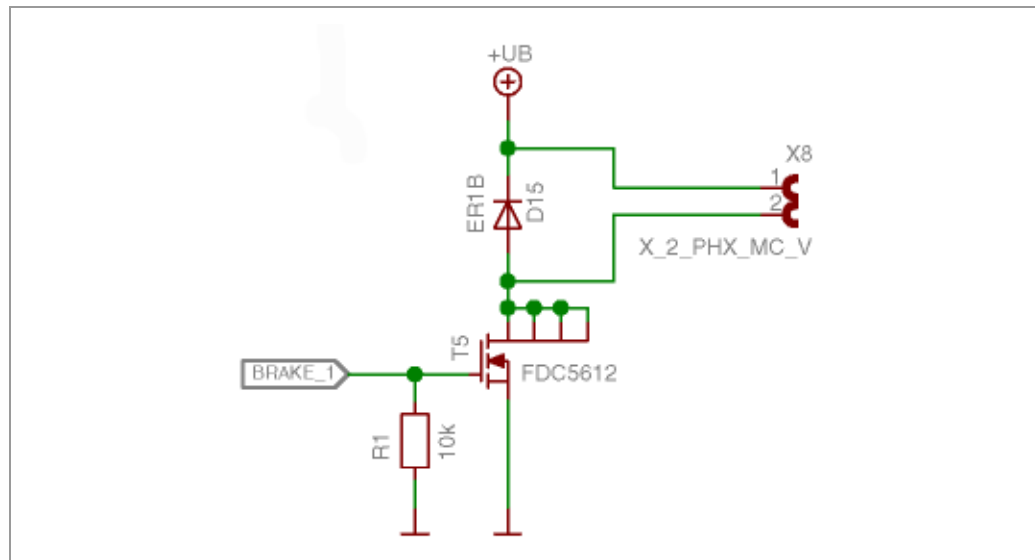

3.5 Ballast connection

Function

The ballast output is used by the controller to indicate overvoltage at the supply.

Circuit on the motherboard

The motherboard should have a circuit that protects the controller against brief voltage peaks as can occur through the reverse feeding of the motors in the generator mode.

The connection diagram of the evaluation board shows a version of the ballast circuit that conducts the excess voltage/energy to a resistor with the aid of a transistor, where it is converted to heat. This resistor is also referred to as the "Brake resistor" because the energy usually arises from braking of the motor.

This protects the SMCP33 against destruction from brief overvoltage. The rating and cooling of the resistor determines how long it can convert the overvoltage before it becomes too hot and is destroyed.

3.6 Encoder connection

Optional encoder

An optional encoder can be connected to the stepper motor control.

By default, the closed-loop control for a three-channel encoder is set up with 500 pulses/revolution in an 1.8° stepping motor. With an 0.9° stepping motor, you should use an encoder with 1000 pulses/revolution to achieve the same control quality. Depending on the application, it may make sense to use higher encoder resolutions (up to max. 2000 pulses/revolution) to improve control quality or to use a lower resolution (min. 200 pulses/revolution) for low-cost applications or for step monitoring alone.

The following encoder resolutions can normally be processed by the controller: 192, 200, 256, 400, 500, 512, 1000, 1024, 2000, 2048.

Recommended:

Where possible, use Nanotec encoders with the order number HEDS/HEDL-5541 Xxx.

If an encoder is **not** used, the "Disable" mode must be set in the <Error correction> tab in the "Rotation Direction Mode" selection menu. See the separate manual on NanoPro.

Using encoders with line drivers

The encoders of the HEDL series with line drivers output an inverted signal in addition to the encoder signal; this leads to better interference immunity and is especially recommended for long lines lengths.

The differential signal can be evaluated with a line driver/encoder adapter.

The following figure shows the input circuit of the encoder for channel A (Ch A) with an inverted signal (Ch A_I).

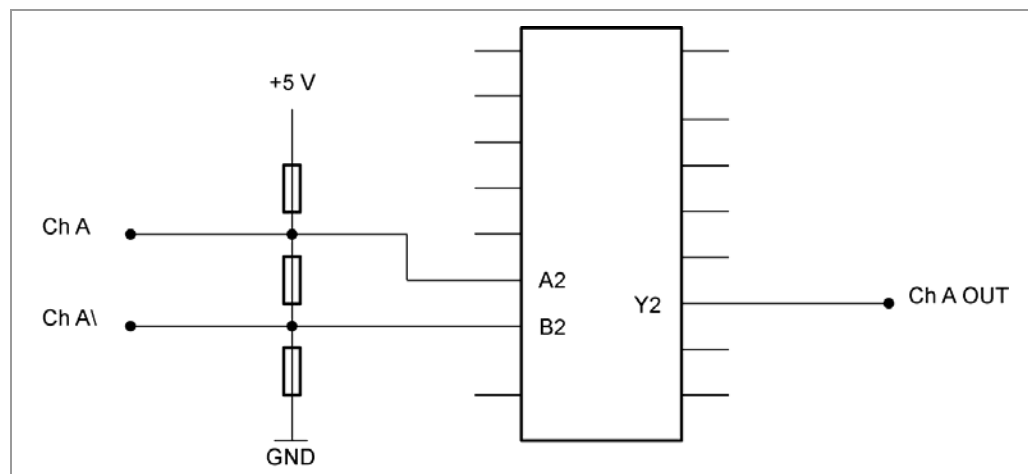

The SMCP controllers themselves currently cannot evaluate the differential signal, meaning that only the channels A, B and I need to be connected to perform position monitoring. We recommend shielding and twisting the encoder line to minimize interference with the encoder signal from the outside.

3.7 Stepper motor connection

Connection cable

The motor is connected to the SMCP33 with a 4-wire cable. Twisted wire pair cables with braided shields are recommended.



Danger of electrical surges

Mixing up the connections can destroy the output stage! See also data sheet of connected stepper motor (colour code of 4 wires).

Never disconnect the link when operating voltage is applied!

Never disconnect lines when live!

Motor with 6 or 8 connections

If you are using a motor with 6 or 8 connections, you need to connect the windings.

The diagram on the next page shows four wiring plans for motors with 6 or 8 connections (page from the Nanotec product catalogue).

Details can be found on the Nanotec website www.nanotec.com.

8 lead wire - parallel for high frequency > 1 kHz

current per winding x 1,4 = current per Phase
 example: current / winding 1A = 1,4A / Phase

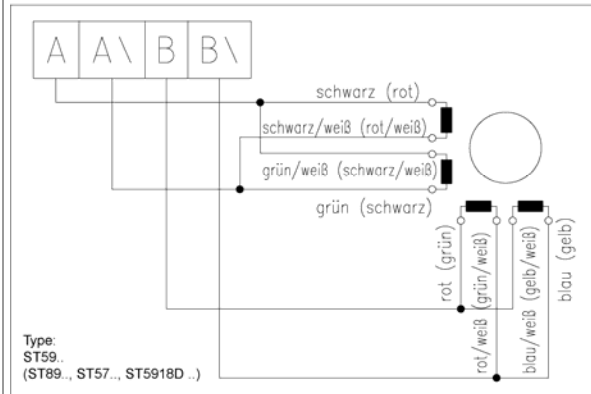

8 lead wire - serial for low frequency < 1 kHz

current per winding x 0,7 = current per Phase
 example: current / winding 1A = 0,7A / Phase

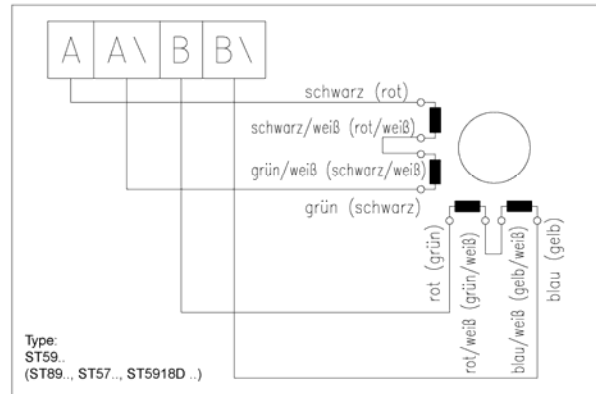

6 lead wire

current per winding = current per Phase
 example: current / winding 1A = 1A / Phase

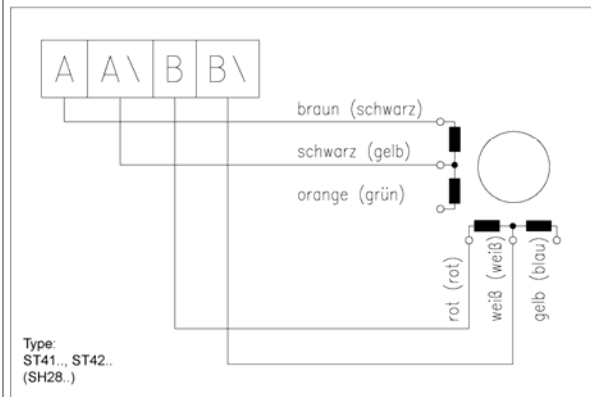

current per winding x 0,7 = current per Phase
 example: current / winding 1A = 0,7A / Phase

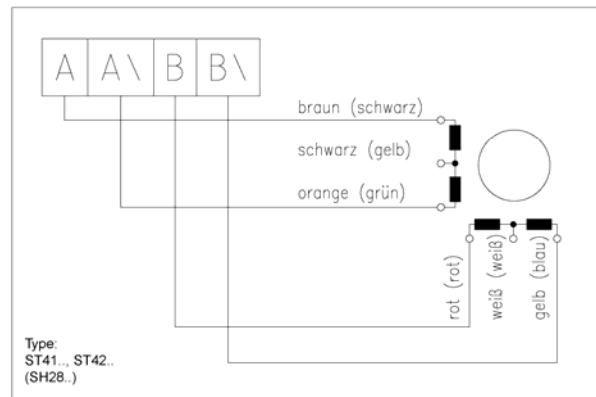

4 lead wire

current per winding = current per Phase
 example: current / winding 1A = 1A / Phase

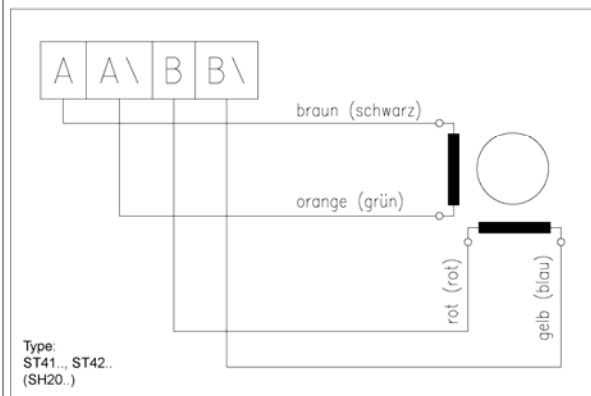

current per winding = current per Phase
 example: current / winding 1A = 1A / Phase

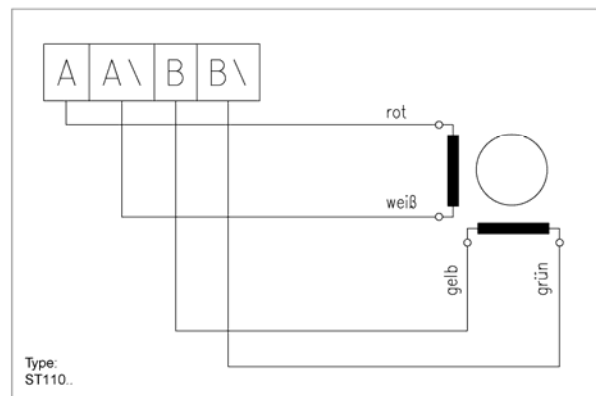

3.8 Power supply connection

Permissible operating voltage

The permissible operating voltage of the SMCP33 stepper motor control lies within the range +12 to +48 V DC and must not exceed 50 V or undershoot 10 V.

A charging condenser with minimum 4700 µF (10000 µF) must be provided for the operating voltage to prevent exceeding the permissible operating voltage (e.g. during braking).



Danger of electrical surges

Connect charging condenser with minimum 4700 µF!

Connect a condenser with 10000 µF for motors with flange size 86x86 (series ST8918) or greater!

An operating voltage > 50 V will destroy the output stage!

Mixing up the connections can destroy the output stage! See also data sheet of connected stepper motor (colour code of 4 wires).

Never disconnect the link when operating voltage is applied!

Never disconnect lines when live!

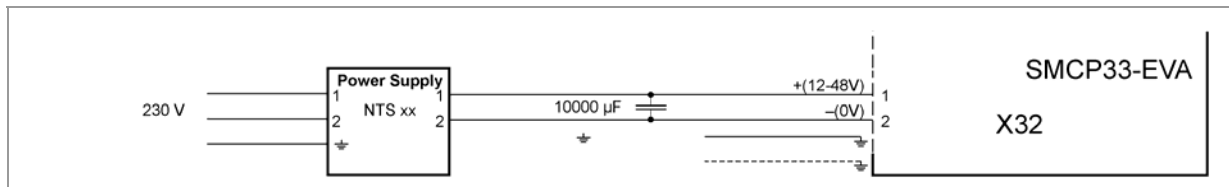

Accessories

Appropriate power packs and charging condensers are available as accessories:

Name	Order number
Power pack	NTS-xxV-xA
Charging condenser	Z-K4700 or Z-K10000

Further information about accessories can be found on the Nanotec website:
www.nanotec.com

3.9 RS485 communication

SMCP33 in a network

Up to 255 stepper drives can be controlled in a network from a PC or PLC.

This network connection is set up via the RS485 port.

Example: Connection to SMCP33-EVA

On the SMCP33-EVA motherboard shown in section 3.2 SMCP33-EVA evaluation board, four stepper motors can be rapidly commissioned via a pre-wired RS485 network and a PC connection.

For the PC connection, either a serial D-Sub 9 port (X29) or the USB port (X30) of the SMCP33-EVA motherboard can be used.

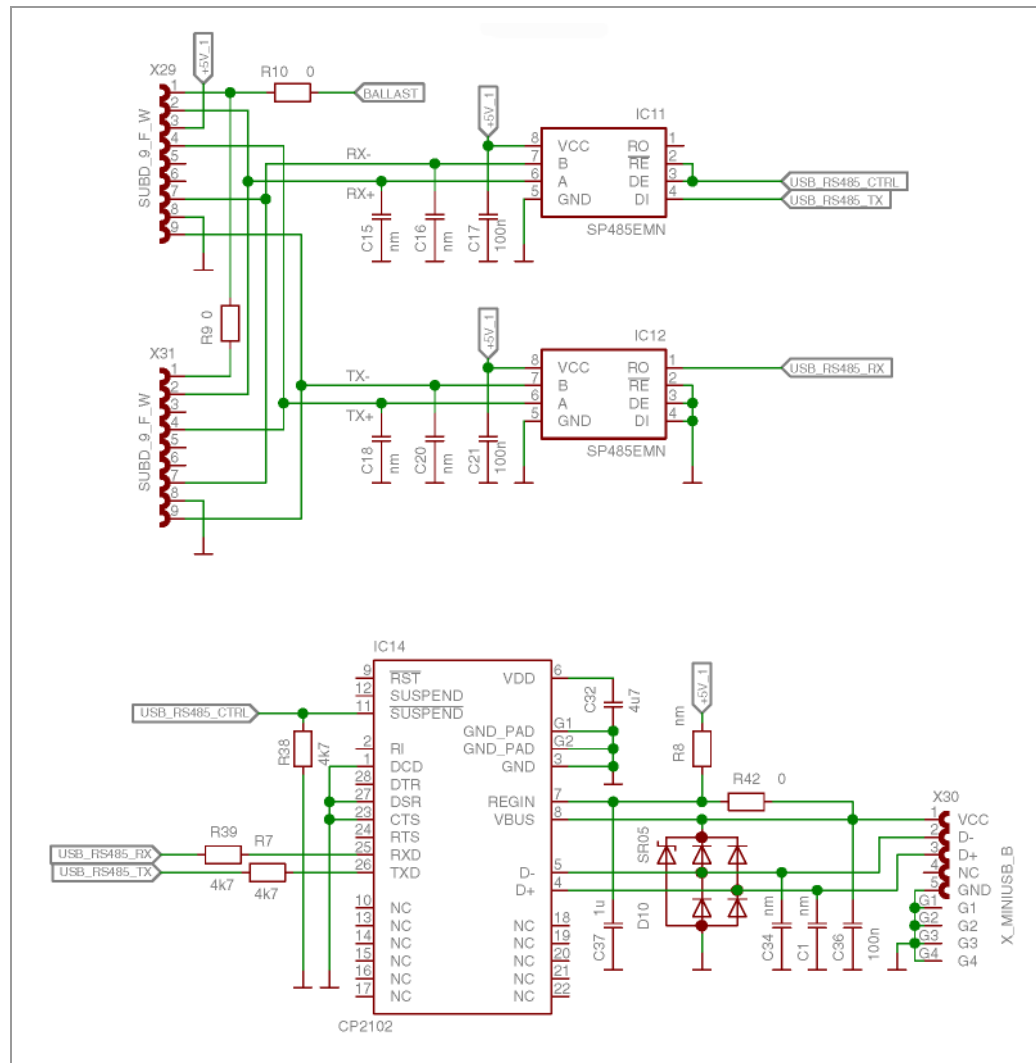

Use the following converter cable:

- ZK-RS485-RS232 for connection to the serial port
- ZK-RS485-USB for connection to the USB port

4 Operating modes

Introduction

Depending on the drive profile, the motor can be operated using a total of 14 different operation modes. Due to the good performance and variety of functions available, they offer designers and developers a rapid and simple method of resolving numerous drive requirements with less programming effort.

Select the required operating mode for each drive profile and configure the controller according to your requirements.

More detailed information can be found in the separate NanoPro manual.

Overview of operating modes and their areas of application

Operation Type	Application
Relative	Use this mode when you wish to travel to a specific position. The motor travels according to a specified drive profile from a Position A to a Position B.
Absolute	
Internal Homing	During the internal reference run, the motor travels to an internal reference point at the set minimum speed.
External Homing	During an external reference run, the motor travels to a switch connected to the reference input.
Speed mode	Use this mode when you wish to travel with a specific speed (e.g. a conveyor belt or pump speed). In the speed mode, the motor accelerates with a specified ramp from the starting speed (start frequency "V Start") to the specified maximum speed (maximum frequency "V Normal"). Several inputs enable the speed to be changed on-the-fly to different speeds.
Flag positioning mode	The flag positioning mode offers a combination of the speed and positioning modes. The motor is initially operated in speed mode; when a trigger point is reached, it changes to the positioning mode and the specified setpoint position (relative to the trigger position) is approached. This operating mode is used for labeling, for example: the motor first travels with the set ramp to the synchronous speed of the conveyed goods. When the labels are detected, the preset distance (position) is traveled to apply the labels.

Operation Type	Application
Clock direction mode, left	Use this mode when you wish to operate the motor with a superordinate controller (e.g. CNC controller). In the clock direction mode, the motor is operated via two inputs with a clock and a direction signal from a superordinate positioning control (indexer). Depending on the mode selected (Int. Ref. / Ext. Ref.), the internal and external reference runs are supported.
Clock direction mode, right	
Clock direction mode, Int. Ref.	
Clock direction mode, Ext. Ref.	
Analogue and Joystick mode	The motor is controlled in this operating mode simply with a potentiometer or a joystick (-10 V to +10 V). Use this mode if you want to use the motor in a simple application: <ul style="list-style-type: none"> • Setting a specific speed, e.g. via an external potentiometer, • Traveling synchronously with a superordinate controller with analogue output (-10 V to +10 V).
Analogue positioning mode	Use this mode when you wish to travel to a specific position. The voltage level on the analogue input is proportional to the required position, thus enabling servo behavior.
Torque mode	Use this mode when you require a specific output torque independent of the speed as is the case in typical winding and unwinding applications. The maximum torque is specified via the analogue input.

Selecting the operating mode in NanoPro

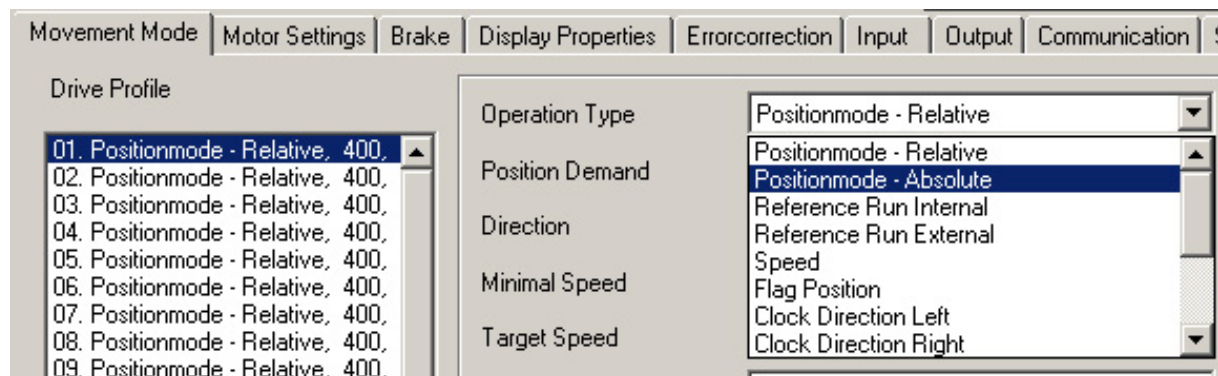

5 Troubleshooting

Troubleshooting procedure

Proceed with care during troubleshooting and error rectification to avoid damaging the controller.



Danger of electrical surges

An operating voltage > 50 V and incorrect connections can destroy the end stage.
Never disconnect the link when operating voltage is applied!
Never disconnect lines when live!

Possible error

Error	Possible cause	Rectification
Controller is not ready	Data transmission to SMCP33 is not possible (communication error): Incorrect COM port selected.	In the <Communication> tab, select the PC port to which you connected the SMCP33 (e.g. "COM-1"). The port used can be found in the device manager of your PC.
	Communication cable not connected or interrupted (incorrect converter used).	Function is not guaranteed with third-party 4-wire cables and 2-wire Nanotec converters do not function. Use the recommended RS232-RS485 converter from Nanotec: <ul style="list-style-type: none"> Order number: ZK-RS485-RS232
	A non-existent motor number (module number) is set.	Set the correct module address. See the separate manual on NanoPro.
	The power supply of the SMCP33 is interrupted.	Check voltage supply, switch on if necessary.
	Another open program is blocking the COM port to which the SMCP33 is connected.	Close down other programs on your PC.
	Inadmissible data was sent to the controller during the output of a travel profile.	Click on the <Yes> button to stop the travel profile. The SMCP33 switches back to the "Ready" state. The data can then be resent to the controller.
Transmission error	Data transmission to the SMCP33 is disturbed (sender or receiver are disturbed).	Check the possible causes for the transmission error and rectify the cause of the error.
Position error	A button was clicked while the controller was in error mode (position error or limit switch in normal operation).	Click the <Yes> button in the error message: the error is reset.
Red LED on the SMCP33 lights up.	Overtemperature of power electronics > 75 °C	Switch off controller and allow to cool. The error is reset when the SMCP33 is disconnected from the power supply unit.
	Undervoltage	Check voltage supply.

6 Technical data

Electrical connections

Operating voltage Vb	DC 12 V to 48V \pm 4%
Max. phase current	SMCP33: nominal current 2 A, adjustable up to max. 3 A/phase SMCP33-K (with heat sink): nominal current 4 A
Current drop	Adjustable 0 to 100% of phase current
RS-485 interface	<ul style="list-style-type: none"> • 115200 Baud (adjustable) • 1 Startbit, 8 Databits, 1 Stopbit • No parity

Controller parameters

Step resolution	Full step Half step Quarter step Fifth step Eighth step Tenth step 32th step 64th step Adaptive microstep (1/128)
Step angle	1.8°
Operating modes	Position Speed Flag position Clock direction Analogue Analogue Position mode Joystick Torque
Step frequency	0 to 50 kHz in clock direction mode 0 to 25 kHz in all other modes
Position monitoring	Automatic error correction to 0.9° only with optical encoder (e.g. HEDS5541 series)

Inputs and outputs

Inputs	8 digital inputs with optocoupler (5 V) <ul style="list-style-type: none"> • Safe switch off: max. 2 V • Safe switch on: min. 4.5 V 2 analogue inputs
Output	8 transistor outputs <ul style="list-style-type: none"> • Open collector (0 switching, max. 5 V/25 mA) 1 brake output, 1 ballast output

Protective circuits

Overvoltage and undervoltage	Protective circuit for voltages > 50 V or < 10 V
Max. heat sink temperature	Approx. 80 °C External ventilation may be required in full step operation, depending on the switch-on duration, current drop set and external cooling area.
Ambient temperature	0 to 40 °C

SMCP33 dimensions

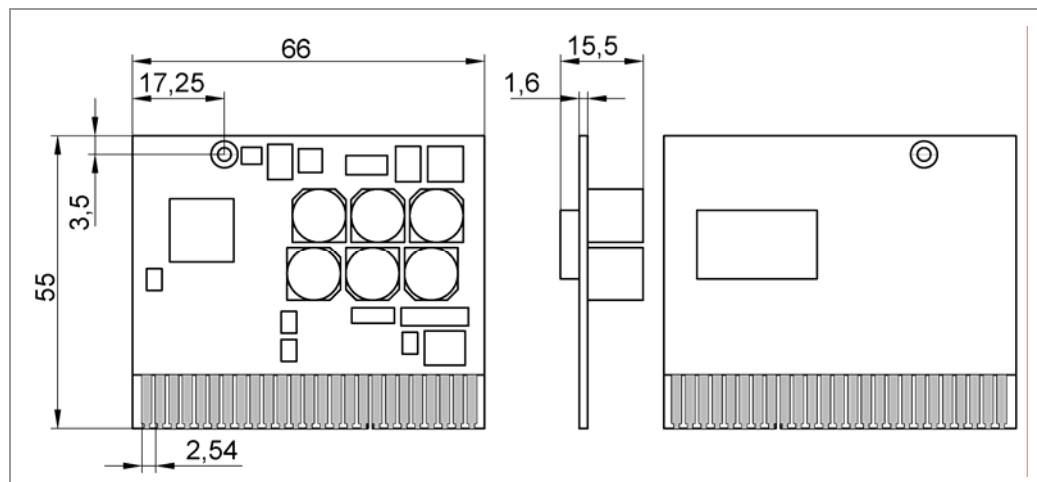

SMCP33-K dimensions (with heat sink)

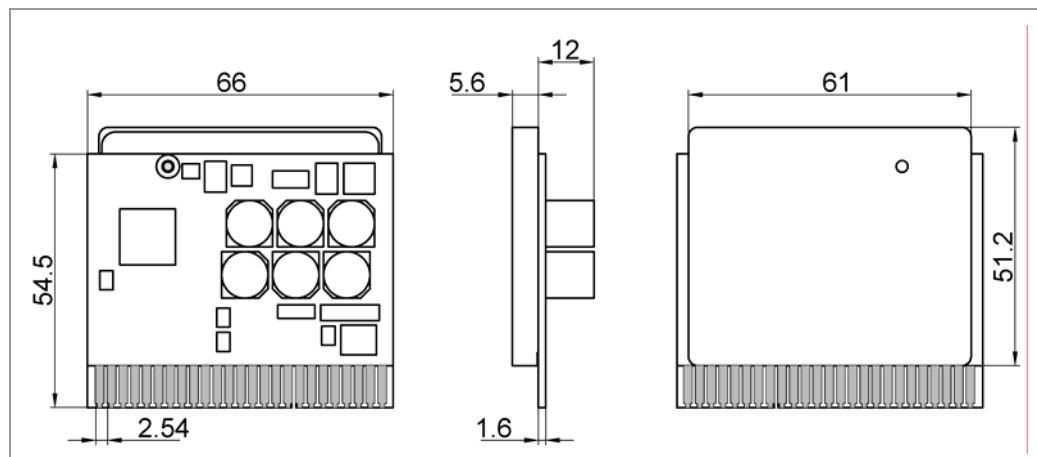

A complete set of datasheets is available for downloading at www.nanotec.de.

Mating connector/board holder, EADC types

Mating connector: 345-050-521-202

Inline plug-in unit, short: 345-220-088

Encoding element between contact: 345-240-318

Index

A

Accessories for voltage supply 19

B

Ballast connection 15

Brake 15

C

Closed-Loop current control 5

E

Encoder 6, 16

External Homing 21

I

Input circuits 13

Inputs 14

Internal Homing 21

M

Motor connection 17

O

Operating modes 21

Operating voltage 19

Output 14

Output circuits 13

P

Pin assignment 9

Protective circuits 26

R

Reference run 21

Rotation monitoring 6, 16

RS485 communication 20

S

SMCP33 functions 5

V

Variants 5

Voltage supply 19