

PD2-C/CB-IP USB



Short instructions Version 1.0.0
Original: de
Nanotec Electronic GmbH & Co. KG Phone: +49 (0)89-900 686-0
Kapellenstraße 6 Fax: +49 (0)89-900 686-50
85622 Feldkirchen, Germany info@nanotec.de

Introduction

The *PD2-C-IP* is a brushless motor with integrated controller in protection class IP65. The integrated absolute encoder makes immediate operation possible in closed loop mode without homing.

This document describes the installation and commissioning of the motor. You can find the detailed documentation for the product on the Nanotec website us.nanotec.com. The short instructions do not replace the technical manual of the product.

Copyright, marking and contact

Copyright © 2013 – 2018 Nanotec® Electronic GmbH & Co. KG. All rights reserved.



Intended use

The *PD2-C-IP* motor with integrated controller is designed for use under the approved **Environmental conditions**.

Any other use is considered unintended use.



Note

Changes or modifications to the product are not permitted.

Warranty and disclaimer

Nanotec produces component parts that are used in a wide range of industrial applications. The selection and use of Nanotec products is the responsibility of the system engineer and end user. Nanotec accepts no responsibility for the integration of the products in the end system.

Under no circumstances may a Nanotec product be integrated as a safety controller in a product or construction. All products containing a component part manufactured by Nanotec must, upon delivery to the end user, be provided with corresponding warning notices and instructions for safe use and safe operation. All warning notices provided by Nanotec must be passed on directly to the end user.

Our general terms and conditions apply: en.nanotec.com/service/general-terms-and-conditions/.

Specialist staff

Only specialists may install, program and commission the device:

- Persons who have appropriate training and experience in work with motors and their control.
- Persons who are familiar with and understand the content of this technical manual.
- Persons who know the applicable regulations.

EU directives for product safety

The following EU directives were observed:

- RoHS directive (2011/65/EU, 2015/863/EU)
- EMC directive (2014/30/EU)

Other applicable regulations

In addition to this technical manual, the following regulations are to be observed:

- Accident-prevention regulations
- Local regulations on occupational safety

Safety and warning notices

Note



- Damage to the controller.
- Changing the wiring during operation may damage the controller.
- Only change the wiring in a de-energized state. After switching off, wait until the capacitors have discharged.

Note



- Fault of the controller due to excitation voltage of the motor.
- Voltage peaks during operation may damage the controller.
- Install suitable circuits (e.g., charging capacitor) that reduce voltage peaks.

Note



- There is no polarity reversal protection.
- Polarity reversal results in a short-circuit between supply voltage and GND (earth) via the power diode.
- Install a line protection device (fuse) in the supply line.

Note



- The device contains components that are sensitive to electrostatic discharge.
- Improper handling can damage the device.
- Observe the basic principles of ESD protection when handling the device.

Technical details and pin assignment

Environmental conditions

Environmental condition	Value
Protection class	IP65 (except shaft)
Ambient temperature (operation)	-10 ... +40°C
Air humidity (non-condensing)	0 ... 85%
Altitude of site above sea level (without drop in performance)	1500 m
Ambient temperature (storage)	-25 ... +85°C

Electrical properties and technical data

Technical data – motor

	Operating voltage	Phase current rms	Peak current for 1 s
PD2-C	12 V to 48 V	1.8 A	Max. 3 A RMS
PD2-CB42C	12 V to 48 V	3.3 A	Max. 10 A RMS

Technical data

Property	Description / value
Operating modes	<i>Profile Position Mode, Profile Velocity Mode, Profile Torque Mode, Velocity Mode, Homing Mode, Interpolated Position Mode, Cyclic Sync Position Mode, Cyclic Sync Velocity Mode, Cyclic Synchronous Torque Mode, Clock-Direction Mode</i>
Set value setting / programming	<i>Clock-direction, analog, NanoJ program</i>
Inputs	2 digital inputs (+24 V) 3 inputs, single-ended or differential, +5 V / +24 V, switchable by means of software 1 analog input, 10-bit resolution, 0-10 V or 0-20 mA (switchable by means of software, default setting is 0-10 V)
Outputs	2 outputs, max. 24 V, 100 mA, open drain
Integrated encoder	Magnetic, single-turn absolute encoder, 1024 pulses/revolution

Property	Description / value
Protection circuit	Overvoltage and undervoltage protection Overtemperature protection (> 75° Celsius on the power board) Polarity reversal protection: In the event of a polarity reversal, a short-circuit will occur between supply voltage and GND over a power diode; a line protection device (fuse) is therefore necessary in the supply line. The values of the fuse are dependent on the application and must be dimensioned <ul style="list-style-type: none"> greater than the maximum current consumption of the controller less than the maximum current of the voltage supply. <p>If the fuse value is very close to the maximum current consumption of the controller, a medium / slow tripping characteristics should be used.</p>

Dimensioned drawings

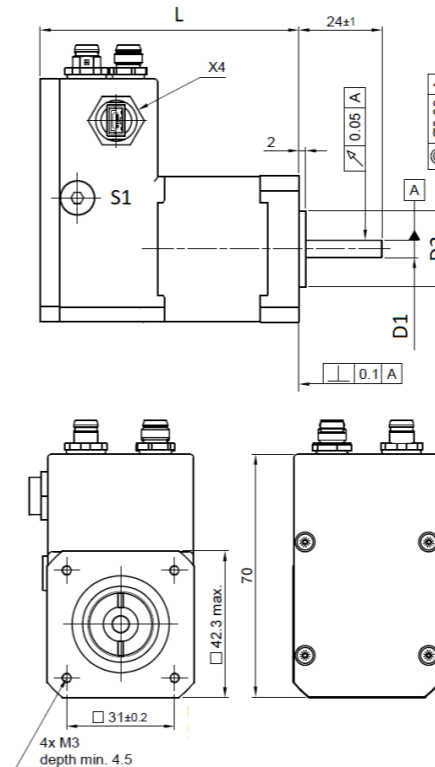

Dimension	Value
L	<ul style="list-style-type: none"> PD2-C411L18-E-65: 74.4±1 PD2-CB42CD-E-65: 123.9±1
D1	<ul style="list-style-type: none"> PD2-C411L18-E-65: 5⁺⁰_{-0.012} PD2-CB42CD-E-65: 5⁺⁰_{-0.013}
D2	<ul style="list-style-type: none"> PD2-C411L18-E-65: 22⁺⁰_{-0.05} PD2-CB42CD-E-65: 22⁺⁰_{-0.025}

Overtemperature protection

Above a temperature of approx. 75°C on the power board (corresponds to 65–72°C outside on the back cover), the power part of the controller switches off and the error bit is set. After cooling down and confirming the error, the controller again functions normally.

LED signaling

Power LED

Normal operation

In normal operation, the green power LED flashes briefly once per second.

Case of an error

The following table shows the meaning of the error numbers.

Flash rate	Error
1	General
2	Voltage
3	Temperature
4	Overcurrent
5	Controller
6	Watchdog-Reset



Note

For each error that occurs, a more precise error code is stored in object **1003_n**.

Pin assignment

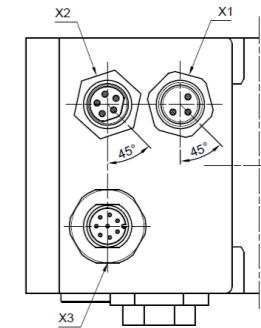

Connector	Function	Pin assignment / description
X1	Voltage supply 12-48 V DC±5%	1. +UB 3. GND 4. n.c.
X2	digital inputs and outputs Switching thresholds for digital inputs 1 - 2 : On: >14.74 V; Off: <3.78 V	1. GND 2. Digital input 1: 24 V Signal 3. Digital input 2: 24 V Signal 4. Digital output 1: Open drain, max 24 V/100 mA 5. Digital output 2: Open drain, max 24 V/100 mA
X3	Analog input and digital inputs Switching thresholds for digital inputs 4 - 6 (Pins 3 - 8) : 5 V (factory setting): On: >4.09 V; Off: <0.95 V 24 V: On: >14.74 V; Off: <3.78 V	1. GND 2. Analog input: 10 Bit, 0-10 V (factory setting) or 0-20 mA, switchable with object 3221_n 3. -Enable (-input 4): 5/24 V and single-ended/differential switchable, max. 1 MHz 4. +Enable (+input 4): 5/24 V and single-ended/differential switchable, max. 1 MHz 5. -Direction (-input 5): 5/24 V and single-ended/differential switchable, max. 1 MHz 6. +Direction (+input 5): 5/24 V and single-ended/differential switchable, max. 1 MHz 7. -Clock (-input 6): 5/24 V and single-ended/differential switchable, max. 1 MHz 8. +Clock (+input 6): 5/24 V and single-ended/differential switchable, max. 1 MHz
X4	USB connection	Mini USB
S1	Hex coding switch for the selection of the special drive modes (Clock-direction/ Analog-speed)	See Commissioning



Note

- EMC: For a DC power supply line longer than 30 m or when using the motor on a DC bus, additional interference-suppression and protection measures are necessary.
- An EMI filter is to be inserted in the DC supply line as close as possible to the controller/motor.
- Long data or supply lines are to be routed through ferrites.

Commissioning

The *Plug & Drive Studio* software offers you an option for performing the configuration and adapting the motor parameters to your application. You can find further information in document *Plug & Drive Studio: Quick Start Guide* at us.nanotec.com.

The controller also offers you the possibility to switch *special drive modes* on/off via the **hex coding switch S1**. You can thereby control the motor directly via the inputs (analog input/clock-direction). See chapter **Special drive modes (clock-direction and analog speed)** for details.

Observe the following notes:

CAUTION



- Moving parts can cause hand injuries.
- If you touch moving parts during running operation, hand injuries may result.
- Do not reach for moving parts during operation. After switching off, wait until all movements have ended.

CAUTION



- In free-standing operation, motor movements are uncontrolled and can cause injuries.
- If the motor is unsecured, it can, e.g., fall down. Foot injuries or damage to the motor could occur.
- If you operate the motor free-standing, observe the motor, switch it off immediately in the event of danger and make certain that the motor cannot fall down.

CAUTION



- Moving parts can catch hair and loose clothing.
- During running operation, moving parts can catch hair or loose clothing, which may lead to injuries.
- If you have long hair, wear a hairnet or take other suitable protective measures when near moving parts. Do not work with loose clothing or ties near moving parts.

CAUTION



- Risk of overheating or fire if there is insufficient cooling.
- If cooling is insufficient or if the ambient temperature is too high, there is a risk of overheating or fire.
- During use, make certain that the cooling and ambient temperature conditions are ensured.

Note

- EMC: Current-carrying cables – particularly around supply and motor cables – produce electromagnetic alternating fields.
- These can interfere with the motor and other devices. Nanotec recommends the following measures:
 - Use shielded cables and earth the cable shielding on both ends over a short distance.
 - Use cables with cores in twisted pairs.
 - Keep power supply and motor cables as short as possible.
 - Earth motor housing with large contact area over a short distance.
 - Lay supply, motor and control cables physically separate from one another.



Configuration

General

The following options are available for configuring the controller:

Configuration file

This file can be saved to the controller via the USB connection. For further information, read chapters **USB connection** and **Configuration file**.

NanoJ program

This program can be programmed, compiled and then transferred to the controller with *NanoJ* via USB. *NanoJ* is integrated in the *Plug & Drive Studio* software. You can find further information in document *Plug & Drive Studio: Quick Start Guide* at us.nanotec.com.

After connecting to a voltage supply, the controller reads out the configuration in the following order:

- The configuration file is read out and processed.
- The hex coding switch for selecting the *special drive modes* is read out and used as configuration. See chapter **Special drive modes (clock-direction and analog speed)**.
- The *NanoJ program* is started.

USB connection

If the controller is connected to a PC via a USB cable, the controller behaves like a removable storage device. No further drivers are required.

Three files are displayed: the configuration file (`cfg.txt`), the NanoJ program (`vmmcode.usr`) and the information file (`info.bin`), where the serial numbers and firmware version of the product can be found.

You can thereby store the configuration file or the NanoJ program on the controller. The voltage supply of the controller must also be connected during USB operation.

Configuration file

General

The `cfg.txt` configuration file is used to preset values for the object dictionary to a certain value during startup. This file uses a special syntax to make accessing the objects of the object dictionary as easy as possible. The controller evaluates all assignments in the file from top to bottom.

Reading and writing the file

How to access the file:

- Connect and switch on the voltage supply.
- Connect the controller to your PC using the USB cable.
- After the PC has detected the device as a removable storage device, navigate in the Explorer to the directory of the controller. File `cfg.txt` (for a PD4C, the file is named `pd4ccfg.txt`) is stored there.
- Open this file with a simple text editor, such as Notepad or Vi. Do not use any programs that use markup (LibreOffice or similar).

Tip

To be able to connect the controller with *Plug & Drive Studio* via the *virtual COM port* mit verbinden zu können, insert the following line:



```
2102:00=0x190001
```

```
DD4C=1
```

After you have made changes to the file, proceed as follows to apply the changes:

- Save the file if you have not yet already done so.
- Disconnect the USB cable from the controller.
- Disconnect the voltage supply from the controller for approx. 1 second until the power LEDs stop flashing.
- Reconnect the voltage supply. When the controller is now restarted, the values in the configuration file are read out and applied.

Structure of the configuration file

Comments

Lines that begin with a semicolon are ignored by the controller.

Assignments

Values in the object dictionary can be set with the following syntax:

```
<Index>:<Subindex>=<Value>
```

Example

Set object 2031_n:00 (rated current) to the value "258_n" (600 mA):

```
2031:00=0x258
```

Set object 3202_n:00 to the value "8" (activate current reduction while at a standstill in *open loop* mode):

```
3202:00=8
```

Set object 2057_n:00 to the value "512" and object 2058_n to the value "4" (*quarter step* step mode in clock-direction mode):

```
2057:00=512
```

```
2058:00=4
```

Special drive modes (clock-direction and analog speed)

You have the possibility to control the motor directly via the clock and direction input or the analog input by activating the *special drive modes*.

Digital input 4 serves here as an enable.

Activation

To select the mode, you must set the hex coding switch to a value between "00"_h and "0F"_h.

On delivery, the switch is set to "1".

The special drive modes are activated on delivery, you can completely deactivate them by inserting this line in the configuration file:

```
dd4c=1
```

The following table lists all possible modes and the value of the switch:

Value	Mode			
00 _h /01 _h	Clock-direction	-	-	Open Loop
02 _h	Test run	Test run with 30 rpm	Clockwise direction of rotation	Open Loop
03 _h	Test run	Test run with 30 rpm	Counterclockwise direction of rotation	Open Loop
04 _h	Analog speed	Direction via "Direction" input	Maximum speed 1000 rpm	Open Loop
05 _h	Analog speed	Direction via "Direction" input	Maximum speed 100 rpm	Open Loop
06 _h	Analog speed	Offset 5 V (joystick mode)	Maximum speed 1000 rpm	Open Loop
07 _h	Analog speed	Offset 5 V (joystick mode)	Maximum speed 100 rpm	Open Loop
08 _h /09 _h	Clock-direction	-	-	Closed Loop
0A _h	Test run	Test run with 30 rpm	Clockwise direction of rotation	Closed Loop
0B _h	Test run	Test run with 30 rpm	Counterclockwise direction of rotation	Closed Loop
0C _h	Analog speed	Direction via "Direction" input	Maximum speed 1000 rpm	Closed Loop
0D _h	Analog speed	Direction via "Direction" input	Maximum speed 100 rpm	Closed Loop
0E _h	Analog speed	Offset 5 V (joystick mode)	Maximum speed 1000 rpm	Closed Loop
0F _h	Analog speed	Offset 5 V (joystick mode)	Maximum speed 100 rpm	Closed Loop



Note

A change to the switch does not take effect until after the controller is restarted.

Clock-direction

The controller internally sets the operating mode to **clock-direction**. You must connect the *enable*, *clock* and *direction* inputs.

Analog speed

The controller internally sets the operating mode to **Velocity**. To preset the speed, the voltage on the analog input is used and the corresponding target speed is written in **6042_n**.

Maximum speed

The maximum speed can be changed between 100 rpm and 1000 rpm. If a different speed is necessary, it can be set using the scaling factor (object **604C_n**, subindices 01_h and 02_h).

Computation of the analog voltage

There are two modes for calculating the analog input voltage.

Normal mode

You must connect the *enable*, *direction* and *analog inputs*. The maximum analog voltage corresponds to the maximum speed. The direction is preset here via the direction input. There is a dead zone from 0 V to 20 mV in which the motor does not move.

Joystick mode

You must connect the *enable input* and the *analog input*. Half of the maximum analog voltage corresponds to the speed 0. If the voltage drops below half, the speed increases in the negative direction. If the speed rises above half, the speed increases likewise in the positive direction. The dead zone here extends from $U_{max}/2 \pm 20$ mV.

Test run with 30 rpm

The motor rotates at 30 rpm if the *enable input* is set.