

# PD6-E/EB

Functional description

STO (Safe Torque Off)

# Inhalt

<b>1 Introduction.....</b>	<b>3</b>
1.1 Product documentation.....	3
1.2 Version information.....	3
1.3 Copyright and contact.....	4
1.4 Warranty and disclaimer.....	4
1.5 Intended use.....	4
1.6 EU directives for product safety and certifications.....	5
1.7 Notes and used icons.....	5
1.8 Emphasis in the text.....	5
<b>2 Operating conditions.....</b>	<b>6</b>
2.1 Operational environment.....	6
2.2 Foreseeable misuse.....	6
2.3 Personnel qualifications.....	6
2.4 Requirements on the higher-level safety controller.....	7
<b>3 General safety and warning notices.....</b>	<b>8</b>
<b>4 Description of the <i>STO</i> safety function.....</b>	<b>9</b>
4.1 Control of the <i>STO</i> function.....	10
4.2 Feedback output.....	11
<b>5 Technical details and connections.....</b>	<b>12</b>
5.1 Safety characteristics.....	12
5.2 Connections and electrical properties.....	12
5.2.1 Connection X7 - <i>STO</i> .....	13
<b>6 Installation and initial commissioning.....</b>	<b>15</b>
<b>7 Diagnosis.....</b>	<b>17</b>
7.1 <i>STO</i> function test.....	17
7.2 Status of the <i>STO</i> function.....	17
7.3 Overtemperature protection.....	19
<b>8 Maintenance and service.....</b>	<b>20</b>

# 1 Introduction

The motors of the *PD6-E...S-65...* series support the *STO* safety function (Safe Torque Off). They are designed for installation in machines/systems for which a safe shutdown of the motor torque and a restart lock are required.

This document describes the *STO* function and provides the necessary information for the safe and optimum integration of the device in the control chain so that the safety level required for the machine/system is achieved.

The variants of the product differ with respect to communication interface and motor power. The *STO* function is integrated in all variants with the letter **S** in the article number (*PD6-E...S-65...*) and is implemented uniformly. This document applies for all of them.

## 1.1 Product documentation

All product documentation is available on the respective product page at [us.nanotec.com](https://us.nanotec.com).

Document	Content
Technical Manual <i>PD6-E/EB</i>	Installation, commissioning, parameterization/programming, description of the functions of the motor controller
<i>STO</i> functional description (this document)	Description of the integrated <i>STO</i> safety function for the product variants that include this function ( <i>PD6-E...S-65...</i> )

The technical data in this document refers to the following hardware version of the respective product variant:

Varianten (Feldbus)	Hardware-Version
EtherCAT: <i>PD6-E...S-65-1</i>	0
CANopen: <i>PD6-E...S-65-2</i>	0
EtherNet/IP: <i>PD6-E...S-65-3</i>	0
Modbus TCP: <i>PD6-E...S-65-4</i>	0
Modbus RTU: <i>PD6-E...S-65-5</i>	0
PROFINET: <i>PD6-E...S-65-10</i>	0

You can read the hardware version from object 1009<sub>h</sub>. For details, refer to the technical manual for your variant.

## 1.2 Version information

Table 1: Version information

Document version	Date	Changes
0.9.5	09/2025	DRAFT  <i>Note</i> added regarding the state of the feedback output when a voltage with reverse polarity is applied.
1.0.0	10/2025	Edition
1.0.1	10/2025	Current for <u>feedback output</u> reduced from 100 to 50 mA.

## 1.3 Copyright and contact

© 2013 – 2025 Nanotec Electronic GmbH & Co. KG. All rights reserved.

Nanotec Electronic GmbH & Co. KG

Kapellenstraße 6

85622 Feldkirchen

Germany

Phone: +49 89 900 686-0

Fax: +49 (89) 900 686-50

[us.nanotec.com](http://us.nanotec.com)

## 1.4 Warranty and disclaimer

Nanotec produces *component parts*, *partly completed machinery* and *safety components* that are used in a wide range of industrial applications. The selection and use of Nanotec products is the responsibility of the plant engineer and end user.

With *component parts*, Nanotec assumes absolutely no responsibility for the integration of the products in the end system. With *partly completed machinery*, Nanotec's responsibility is limited to the procedures/interfaces described in the assembly instructions for the installation of the *partly completed machinery* in the machinery. For *safety components*, responsibility is limited to the procedures/interfaces for installation of the *safety component* in the machine described in this STO function description.

With the exception of *safety components*, under no circumstances may a Nanotec product be integrated as a safety controller in a product or construction.

All products containing a *component part* or *partly completed machinery* or a *safety component* manufactured by Nanotec must, upon delivery to the end user, be provided with corresponding warning notices and instructions for safe use and safe operation. All warning notices provided by Nanotec must be passed on directly to the end user.

Our general terms and conditions apply: [General Terms and Conditions](#).

## 1.5 Intended use

The *PD6-E...S-65...* motor controllers are designed for installation in machines/systems and for use in the industrial sector.

All *PD6-E...S-65...* product variants of the PD6-E/EB series support the *STO* safety function (Safe Torque Off). The *STO* function is used for the safe shutdown of the motor torque.

The *STO* function integrated in the *PD6-E...S-65...* is intended to be used as follows:

- within the limits defined in the technical data (especially the voltage ranges of the product and of all connected components) and under the environmental conditions that you can find in the *PD6-E/EB technical manual*,
- under the approved [operating conditions](#)
- and only if the [safety characteristics](#) specified in this document are sufficient for achieving the safety level required for the application.



### NOTICE

Changes or modifications to as well as opening of the product are not permitted.



## 1.6 EU directives for product safety and certifications

The following EU directives were observed:

- RoHS directive (2011/65/EU, 2015/863/EU)
- Machinery directive (2006/42/EC)
- EMC directive (2014/30/EU)

## 1.7 Notes and used icons

All notices are in the same format. The degree of the hazard is divided into the following classes.

<b>CAUTION!</b>	
	<p><b>The CAUTION notice indicates a possibly dangerous situation.</b></p> <p>Failure to observe the notice <b>may</b> result in moderately severe injuries.</p> <p>▶ Describes how you can avoid the dangerous situation.</p>
<b>NOTICE</b>	
	<p><b>Indicates a possible incorrect operation of the product.</b></p> <p>Failure to observe the notice may result in damage to this or other products.</p> <p>▶ Describes how you can avoid the incorrect operation.</p>
<b>TIP</b>	
	<p>The <i>Tip</i> notice provides assistance on operating the product.</p>

## 1.8 Emphasis in the text

The following conventions are used in the document:

Underlined text indicates cross references and hyperlinks:

- You can find the electrical properties of the feedback output in chapter Connections and electrical properties.

Text set in *italics* marks named objects:

- You can find further details on this topic in chapter *CiA 402 Power State Machine* in the technical manual of the *PD6-E...S-65...*
- Read the *installation manual*.
- Use the *Plug & Drive Studio* software to perform the auto setup.

## 2 Operating conditions

To use the STO function properly and safely and to achieve the necessary safety level for your application:

- read this document and make it available to the personnel responsible for commissioning,
- observe the notes and warnings in this document and those for safe operation in the PD6-E/EB technical manual,
- perform a risk assessment for the entire machine/system,
- only use components that correspond to the safety category of the application,
- do not use the STO function until all protective measures have been set up and the validation has been concluded after commissioning.

### 2.1 Operational environment

The products of the *PD6-E...S-65...* series are designed for use in a second environment as defined in *EN 61800-3* (in the industrial sector).

Environmental condition	Value
Protection class	IP65 (IP54 at the shaft outlet)
Pollution degree	2
Ambient temperature (operation)	-10 ... +40°C
Ambient temperature (storage and transport)	-25 ... +85°C
Relative humidity, non-condensing	0 ... 85%
Max. altitude of site above <i>sea level</i>	2000 m

### 2.2 Foreseeable misuse

The STO function must not be used to protect against dangers from electrical current. It is used exclusively for switching off the torque and can offer protection from dangerous movements.

The STO function must not be used in applications where switching off the torque can result in dangerous states.

#### CAUTION!

##### **Injuries resulting from movement of the axis while the motor is switched off!**

If an external force acts on an axis (vertical axes, suspended loads and similar) and the motor is switched off, the axis may move. This could result in injuries.

The STO function is not sufficient as a safety function for axes on which a permanent external torque is applied.

- ▶ After requesting the STO function, mechanically stop the axis if necessary.
- ▶ Use, e.g., a mechanical holding brake, to prevent the axis from moving if the motor is switched off.



### 2.3 Personnel qualifications

Only specialists staff may install, program and commission this device. Specialist staff are persons who:

- are familiar with and understand the contents of this document,

- have appropriate training and experience in working with motors and their controller,
- are familiar with the installation of electrical drive systems,
- Know the applicable country-specific, state and local regulations and safety regulations,
- have experience in the area of functional safety of systems.

### 2.4 Requirements on the higher-level safety controller

*PD6-E...S-65...* has an internal diagnosis function and returns information on the status of the STO function via a feedback output (see chapter [Diagnosis](#)).

*PD6-E...S-65...* can, however, not detect all errors and defects (defective cable, short-circuit/cross-circuit on the STO signal lines or similar) and is itself not able to prevent the deactivation of the STO function in case of an error. An external, higher-level safety controller or a safety relay is necessary.

To achieve the safety level and the diagnosis coverage rate (see [Safety characteristics](#)), this higher-level safety controller or the safety relay that controls the STO function must:

- detect short- and cross circuits between the conductors,
- evaluate the STO status via the feedback output,
- perform diagnostic tests (see [Diagnosis](#)),
- in case of an error, ensure the safe state and prevent the STO function from being deactivated.

### 3 General safety and warning notices

Observe the safety and warning notices in all documents (see [Product documentation](#)) and the general safety regulations and notes in the *PD6-E/EB technical manual*.

#### VORSICHT!

**The loss of the safety function may lead to injuries!**



- ▶ Observe the conditions for use for the STO function and the product PD6-E...S-65....
- ▶ Do not bypass the STO function.
- ▶ Do not use the STO function until all protective measures are set up and the validation of the machine/system is concluded after commissioning.

#### VORSICHT!

**Risk of injuries from jerky movements of the motor shaft if the final output stage of the motor fails while the STO function is active!**



In case of a multiple error (simultaneous short circuit of two drivers in two different phases), current may flow in spite of proper shutdown that rotates the rotor a maximum of one pole pitch.

## 4 Description of the STO safety function

The STO function is designed for applications in which the motor torque must be safely shut down. The STO function can be requested by a higher-level safety controller or a safety relay in response to an external event (e.g., actuation of an emergency-stop switch or the opening of a protective door).

The STO function is requested on two channels via the two STO inputs (*STOA\_IN* and *STOB\_IN*) without the involvement of software.

As long as the release voltage is applied on both STO inputs, the STO function is inactive. The gate drivers of the power semiconductors are powered and the motor can be operated.

If this release voltage is lost at the STO inputs, the power for the gate drivers of the power semiconductors that supply the current for the motor windings is safely switched off. As a result, the motor is unable to produce any rotary or holding torque.

A feedback output (*STO\_FB*) indicates the status of the STO function and shall be used by the higher-level safety controller for diagnosis.

The following figure shows the function principle of the STO function and the relevant interfaces of *PD6-E...S-65...*

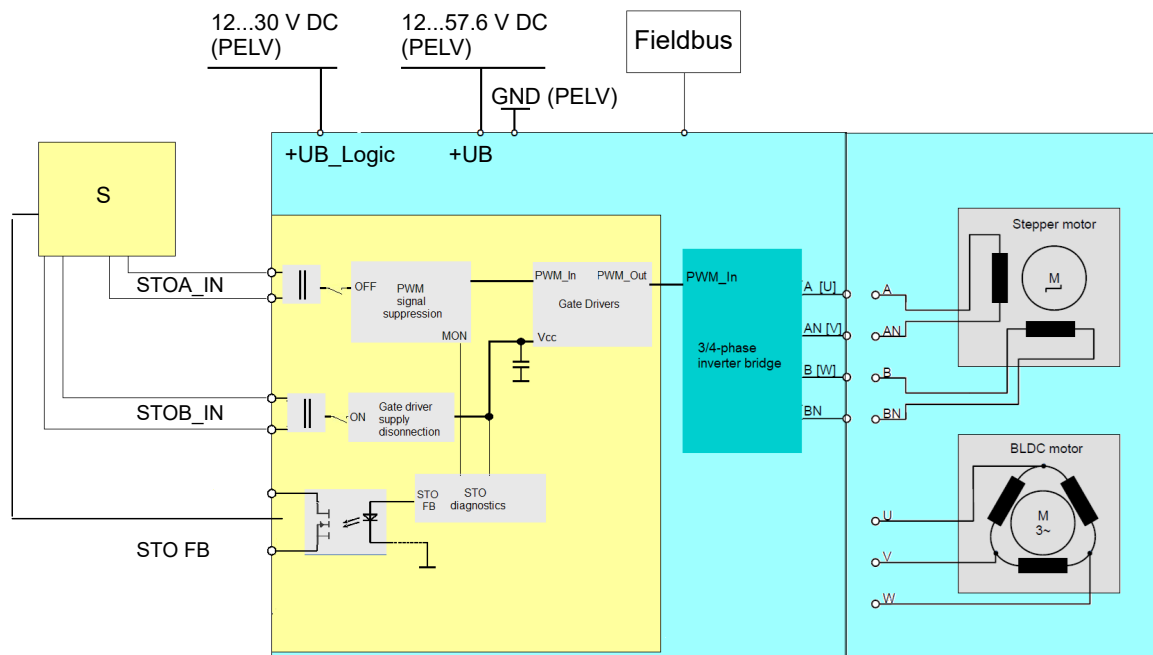

**S**: external safety relay / PLC

**STOA\_IN / STOB\_IN**: STO inputs

**STO\_FB**: feedback output

**+UB\_Logic**: logic voltage; supplies the controller (communication/logic) and the feedback output

**+UB**: main supply (motor/final output stage)

*Abb. 1: Function principle of the STO function in PD6-E...S-65...*

The motor is not actively braked. It comes to a standstill on its own if no external forces act on the motor shaft. The time for the motor to come to a standstill depends on the external forces and on the inertia of the load.

While at a standstill, the motor produces no holding torque and the motor shaft can move as a result of external forces. The motor remains torque-free and cannot restart until the release voltage is again applied at both STO inputs.

#### 4.1 Control of the STO function

The STO function is controlled via STO inputs *STOA\_IN* and *STOB\_IN*. To request the STO function, the higher-level safety controller or the safety relay must switch off the voltage at the STO inputs (see switching thresholds in chapter [Connections and electrical properties](#)). An STO request is not valid until both STO inputs have been switched off.

During switching time  $t_{\text{STO\_ON}}$ , all internal electronic components that store energy (capacitors) are discharged. After time  $t_{\text{STO\_ON}}$  has elapsed, the STO function is activated and the motor is torque-free.

The motor remains torque-free and cannot restart until both STO inputs are set back to High.

During switching time  $t_{\text{STO\_OFF}}$ , all internal electronic components are recharged. After time  $t_{\text{STO\_OFF}}$  has elapsed, the STO function is inactive and the motor can be operated again.

The switching times are dependent on the input voltage and can be max. 50 ms for  $t_{\text{STO\_ON}}$  and 100 ms for  $t_{\text{STO\_OFF}}$ .

The following figure shows the time response during activation/deactivation of the STO function.



Abb. 2: Activation and deactivation of the STO function

After activation of the STO function, *PD6-E...S-65...* is in the error state.

After you have deactivated the STO function, you must acknowledge the error in *PD6-E...S-65...* so that further commands can be accepted. You can find further details on this topic in chapter *CiA 402 Power State Machine* in the *PD6-E/EB* technical manual.

This function is, however, controlled by the firmware of *PD6-E...S-65...* and cannot be regarded as safe.

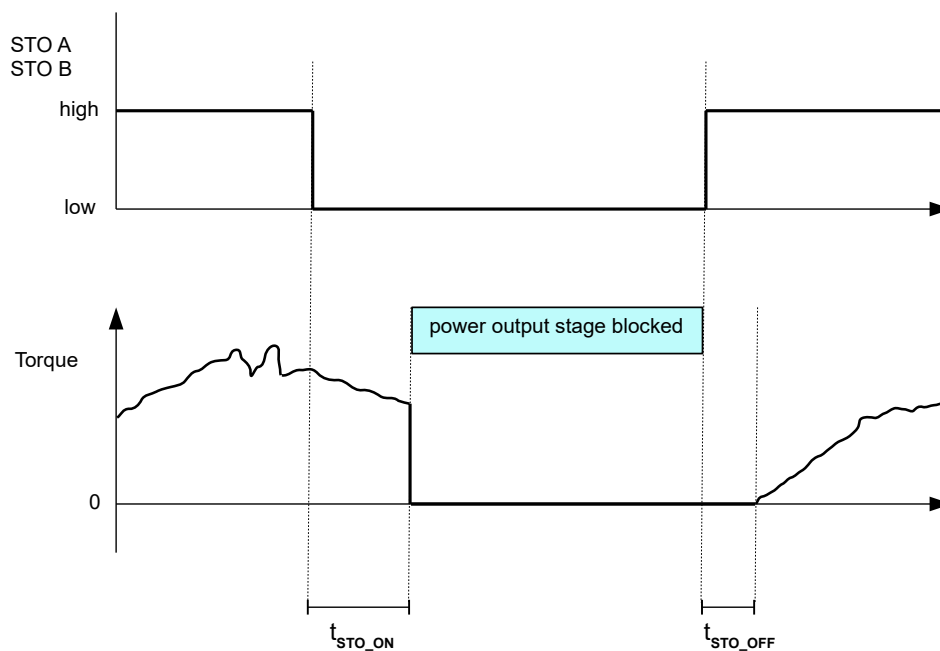
**VORSICHT!****Injuries caused by unexpected startup of the drive!**

PD6-E...S-65... can generate torque after the release voltage is restored at the STO inputs and can start up immediately if programmed incorrectly.

- ▶ To control the STO function, use a safety relay in accordance with the safety category required for the application.
- ▶ Do not deactivate the STO function until you have ensured that no persons or objects can be endangered.

## 4.2 Feedback output

PD6-E...S-65... has an internal diagnosis function that can report the status of the STO function to the higher-level safety controller via feedback output *STO FB*.

The feedback output is implemented as a switch and is set to *High* (semiconductor relay is switched) if the supply voltage for both drivers of the power semiconductors is below the switch-off threshold (5 V). This shows that the STO function is activated and was requested on two channels.

In any other case, the feedback output is on *Low* (semiconductor relay does not switch).

You can find the electrical properties of the feedback output in chapter [Connections and electrical properties](#).

The higher-level safety controller can evaluate the feedback output to detect possible errors with the STO function. You can find further details in chapter [Diagnosis](#).

## 5 Technical details and connections

### HINWEIS



The general technical data, further connection data and a complete description of the device can be found in the *PD6-E/EB technical manual* at [us.nanotec.com](http://us.nanotec.com).

### 5.1 Safety characteristics

Tabelle 2: Safety characteristics

Characteristic value	Value	Description
Safety function	STO	<ul style="list-style-type: none"> <li>■ <i>Safe Torque Off</i> in accordance with EN 61800-5-2 with SIL3</li> <li>■ <i>Safe Torque Off</i> in accordance with ISO 13849-1 with PLe, Category 3</li> </ul>
SIL CL	3	<i>Safety Integrity Level capability</i> in accordance with EN 61800-5-2
PL	e	<i>Performance Level</i> in accordance with ISO 13849-1
Category	3	<i>Category</i> in accordance with ISO 13849-1
DC <sub>avg</sub>	90 %	<i>Average Diagnostic Coverage</i> in accordance with ISO 13849-1
HFT	1	<i>Hardware Failure Tolerance</i> in accordance with EN 61800-5-2
SFF	94.9 %	<i>Safe Failure Fraction</i> in accordance with EN 61800-5-2
PFH <sub>D</sub>	3.74×10 <sup>-9</sup>	<i>Probability of dangerous failure per hour</i> in accordance with ISO 13849-1
MTTF <sub>d</sub>	1137 Jahre	<i>Mean Time To Dangerous Failure</i> (mean time to dangerous failure for each STO channel and for the entire system) in accordance with ISO 13849-1
Mission Time	20 years	

### HINWEIS

**Under some circumstances, additional measures must be taken to achieve the safety characteristics!**



- ▶ Perform a risk assessment for the application and, if necessary, inform the end user of all residual risks.
- ▶ Select the components and perform the wiring according to the required safety category.
- ▶ Observe the Operating conditions and perform the required diagnostics at regular intervals (at least every twelve months).

### 5.2 Connections and electrical properties

The STO connections are located on connector X7.

All connections (voltage supply, I/O, fieldbus) are described in the *PD6-E/EB technical manual*.

### 5.2.1 Connection X7 - STO

Connection for the STO signals.

- Type: M8, A-coded, female

For all *PD6-E...S-65...* variants, the connection is in the same location, as shown in the following figure:



Abb. 3: STO connector X7

#### 5.2.1.1 Pin assignment

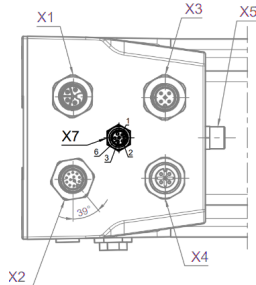

Abb. 4: Pin assignment of the STO connection

Tabelle 3: Pin assignment of the STO connection

Pin	Function	Note
1	STO-A-IN	STO channel A, PWM signal suppression
2	STO-A-RTN	GND connection for STO channel A
3	STO-FBH	STO feedback, High: feedback output for the STO status, see <a href="#">Diagnosis</a>
4	STO-FBL	STO feedback, Low: feedback output for the STO status, see <a href="#">Diagnosis</a>
5	STO-B-IN	STO channel B, gate driver switch
6	STO-B-RTN	GND connection for STO channel B

#### 5.2.1.2 Electrical properties

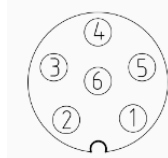
STO inputs *STO-A-IN* and *STO-B-IN* are of type 1 (*current sinking digital inputs*) in acc. with IEC 61131-2.

Tabelle 4: Electrical properties of the STO inputs

Eigenschaft	Beschreibung/Wert
Nominal voltage range	0...30 V DC
High-state voltage range	11...30 V DC
Low-state voltage range	0...5 V DC
High-state current consumption	2 mA @ 11 V...15 mA @ 30
Low-state current consumption	< 2 mA

Feedback output *STO FB* has the following properties:

**Tabelle 5: Electrical properties of the feedback output**

<b>Property</b>	<b>Description / value</b>
Off-state voltage range	0...60 V DC
On-state continuous current	Up to 50 mA
On-state resistance	Max. 40 $\Omega$

## 6 Installation and initial commissioning

This chapter provides notes on the safe installation of the components within the safety circuit of the STO function.

### HINWEIS



In addition, observe all notes regarding installation and commissioning of PD6-E...S-65... in the *PD6-E/EB technical manual*.

### VORSICHT!



#### The loss of the safety function due to incorrect wiring may lead to injuries!

- ▶ Only use components that correspond to the safety category of the application.
- ▶ For the power supply, use only PELV circuits acc. to IEC 60204-1 that permit an absolute maximum voltage of 60 V (even in case of an error).
- ▶ Check the electrical installation (wiring, pin assignment) and validate the STO function prior to the initial commissioning and after every intervention in the wiring and each time components/equipment are replaced.
- ▶ Do not bypass the STO function. If the wiring for the initial commissioning does not correspond to the required safety category of the application, remove it immediately after the initial commissioning.

### VORSICHT!



#### The loss of the safety function due to electromagnetic interference may lead to injuries!

- ▶ Observe the maximum permissible cable length of 30 m for all STO signals. Longer cables reduce the interference immunity (EMC) and require additional interference-suppression and protection measures.
- ▶ Use shielded cables for the STO signals.
- ▶ Lay supply, signal and control cables physically separate from one another.

### HINWEIS



#### Damage to the electronics!

Changing the wiring during operation may damage the electronics.

- ▶ Only perform installation, wiring and cabling if all components are in a voltage-free state.

For the initial commissioning and the function check of the STO function, connect at least the following:

- The main supply at  $+UB$  (12...57.6 V DC) and the logic supply at  $+UB\_Logic$  (12...30 V DC).
- STO inputs *STOA-IN* and *STOB-IN* in parallel and connected to an emergency-off switch or other safety relay. You can connect *STOA\_RTN* and *STOB\_RTN* to the same GND.
- Feedback output *STO FB*; in the following wiring example, this is evaluated by a safety relay.
- The fieldbus cable, to actuate any travel commands.



Abb. 5: Wiring example of PD6-E...S-65... for the initial commissioning with the STO function

Following installation, perform an initial function check.

1. Individually switch off the voltage at each STO input and pay attention to the STO status messages (see [STO function test](#) and [Status of the STO function](#)).
2. Switch off the voltage at both STO inputs, check the reaction of the motor and pay attention to the STO status messages.

## 7 Diagnosis

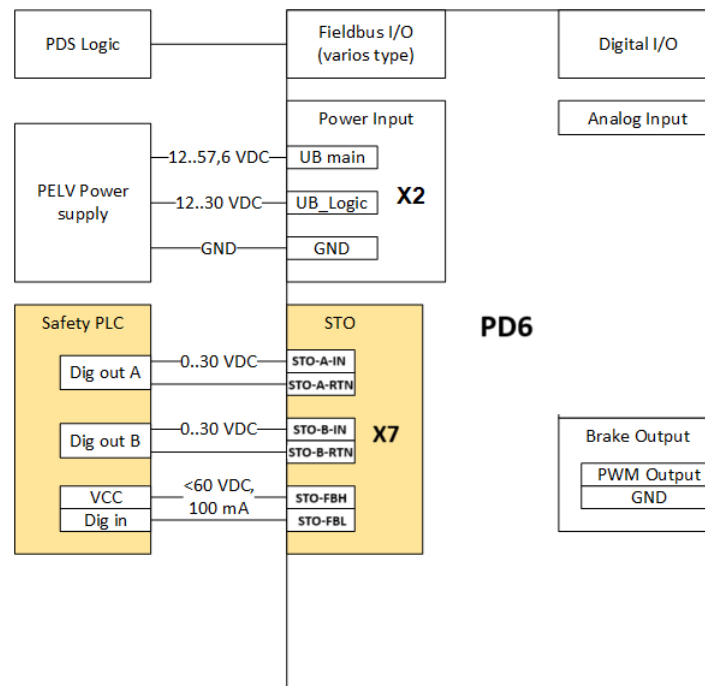
PD6-E...S-65... has an internal diagnosis function that reports the status of the STO function to a higher-level safety controller via feedback output *STO FB*.

### HINWEIS

**To ensure the *average diagnostic coverage*, the status of the STO function must be monitored!**



- ▶ The state of feedback output *STO FB* must be evaluated by the higher-level safety controller following each request of the STO function.
- ▶ In case of an error, a safety-related reaction must take place in accordance with the safety category of the application, depending on the integration of the device in the control chain.

### 7.1 STO function test

With the help of the higher-level safety controller, test the STO function using the following procedure, at least every three months. If you detect deviations during one of the tests described below, take the device out of operation immediately and replace it.

#### Requesting STO

1. Set *STO A* and *STO B* to *High*.
2. Check whether *STO FB* is *Low* (open).
3. Set *STO A* to *Low*.
4. Check whether *STO FB* is *Low* (open).  
→ *STO* has been triggered without errors.
5. Set *STO A* to *High* and *STO B* to *Low*.
6. Check whether *STO FB* is *Low* (open).  
→ *STO* has been triggered without errors.
7. Set *STO A* and *STO B* to *Low*.
8. Check whether *STO FB* is *High* (closed).  
→ *STO* has been triggered without errors.

#### Releasing STO

1. Set *STO A* and *STO B* to *High*.
2. Check whether *STO FB* is *Low* (open).

After acknowledging the error by setting bit 7 in the *controlword*, the motor controller is again ready to accept travel commands and the motor can be energized.

### 7.2 Status of the STO function

The following table lists all possible states of the STO inputs and of the feedback output and the corresponding status of the STO function.

### HINWEIS



In case of an error, the higher-level safety controller must ensure the safe state and prevent further travel commands from being sent.

Tabelle 6: STO status

STO A	STO B	STO FB	Status
High	High	Low (open)	STO function inactive, the motor can be operated
High	High	High (closed)	STO function active even though not requested by the user. Possible causes: <ul style="list-style-type: none"> <li>■ Error in the STO circuit (open circuit, hanging on Low)</li> <li>■ Error in the internal diagnosis system</li> <li>■ Error at the feedback output</li> <li>■ Error in PD6-E...S-65... or overtemperature error in the STO electronics</li> </ul>
High	Low		STO function active
Low	High	Low (open)	Diagnostic test: no error detected.
High	Low		Diagnostic test: internal error detected,
Low	High	High (closed)	
Low	Low	High (closed)	STO function active, supply voltage for both drivers of the power semiconductors below the switch-off threshold
Low	Low	High (delayed)	STO function was activated with delay (>10 ms). Error on STO channel A or B
			STO function requested but safe state not reported back Indicates possible errors: <ul style="list-style-type: none"> <li>■ Error on STO channel A or B</li> <li>■ Error in the internal diagnosis system</li> <li>■ Error at the feedback output</li> </ul>
Low	Low	Low (open)	

#### HINWEIS



Should a voltage with reverse polarity be applied to both contacts *STO-FBH* and *STO-FBL*, the output stays at *High*, independent on the status of the STO function.

**HINWEIS**

In case of a relevant error in *PD6-E...S-65...*, the STO function is automatically requested by the controller.

This is performed by the non-safety-related firmware of *PD6-E...S-65...*



In case of an error, such as overtemperature or undervoltage/overvoltage:

- PD6-E...S-65... automatically requests the STO function, independent of the state of the STO inputs,
- a confirmation is output via feedback output *STO FB* (state of the output is High),
- the error bit in the statusword (object 6041<sub>h</sub>) of the PD6-E...S-65... is set and a more precise error code is stored in object 1003<sub>h</sub> and made available via the fieldbus.

### 7.3 Overtemperature protection

If the temperature on the STO board exceeds 77°C, the STO function is automatically requested, regardless of the state of the STO inputs.

A confirmation is output via feedback output *STO FB* (state of the output is High) and an error is registered in PD6-E...S-65...

After cooling and acknowledgement of the error, the STO function can be used again.

## 8 Maintenance and service

PD6-E...S-65... is maintenance-free; a periodic function check of the safety function by a specialist is, however, still necessary.

The frequency of the function checks is dependent on the safety category of the machine/system; the STO function should be checked at least every twelve months.



### HINWEIS

In case of malfunctions on the device, make no repairs; replace the entire product.

---