

# Mechatronic Solutions

INNOVATE. INTEGRATE. INSPIRE.

NEW PRODUCTS

# Motors with controller

Intelligent compact drives combine motor, controller and single- or multi-turn encoder in a space-saving package. The new **PD6** series comes with a PWM brake output and supports external incremental encoders. With its 80 mm flange and a rated power of 942 W, the **PD6-EB80C** is the most powerful brushless DC motor of this product family. The **PD6-E891** is a stepper motor with a holding torque of up to 10 Nm and an 86 mm flange (NEMA 34).



CANopen

EtherCAT

PROFINET

EtherNet/IP

Modbus

	PD6-EB80	PD6-E891
<b>Motor type</b>	Brushless DC motor	Stepper motor
<b>Size</b>	80 mm	86 mm
<b>Rated power</b>	283 - 940 W	-
<b>Holding torque</b>	-	320 - 933 Ncm
<b>Rated torque</b>	90 - 300 Ncm	-
<b>Rated speed</b>	3,000 rpm	-
<b>Operating voltage</b>	12 - 58 V	12 - 58 V
<b>Digital inputs</b>	6 (5 / 24 V switchable)	6 (5 / 24 V switchable)
<b>Analog input</b>	0 - 20 mA / 0 - 10 V switchable	0 - 20 mA / 0 - 10 V switchable
<b>Digital outputs</b>	2 (open-drain)	2 (open-drain)
<b>Encoder</b>	Single-turn absolute (multi-turn optional)	Single-turn absolute (multi-turn optional)
<b>Encoder resolution</b>	1,024 CPR / 4,096 PPR	1,024 CPR / 4,096 PPR
<b>Interface</b>	USB	USB

# Motors with controller

The **PD1-C28** stepper motor is the latest and smallest member of Nanotec's family of smart servos. Three motor versions are available in each of the two lengths: One with protection class IP20, one with protection class IP65, and a modular variant with open housing that can be modified for applications with custom connectors.

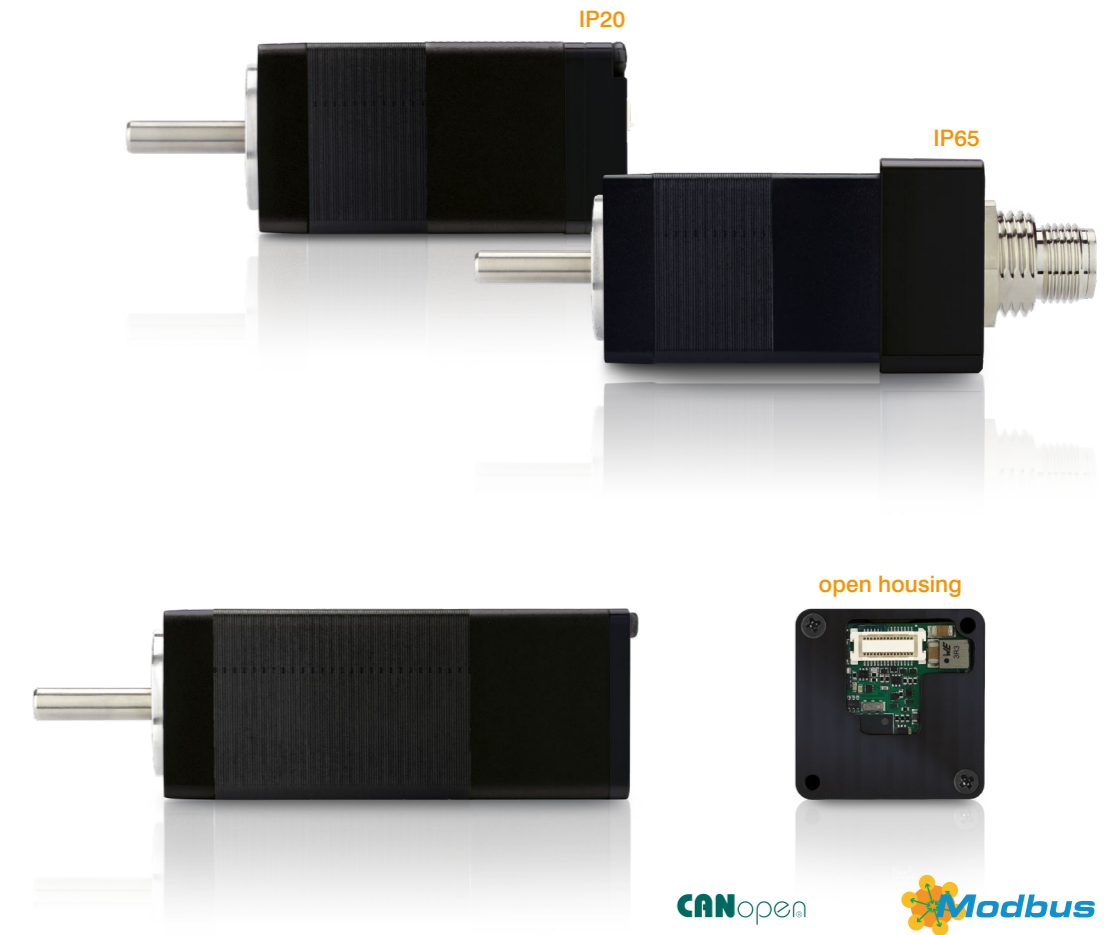

CANopen

Modbus

	PD1-C28S	PD1-C28L
<b>Motor type</b>	Stepper motor	Stepper motor
<b>Size</b>	28 mm	28 mm
<b>Holding torque</b>	9 Ncm	18 Ncm
<b>Operating voltage</b>	12 - 30 V	12 - 30 V
<b>Digital inputs</b>	IP65: 1 / IP20: 4 (5 / 24 V switchable)	IP65: 1 / IP20: 4 (5 / 24 V switchable)
<b>Analog input</b>	0 - 30 V / 12 Bit	0 - 30 V / 12 Bit
<b>Digital outputs</b>	IP65: 1 / IP20: 2 (push-pull)	IP65: 1 / IP20: 2 (push-pull)
<b>Encoder</b>	Single-turn absolute	Single-turn absolute
<b>Encoder resolution</b>	4,096 CPR / 16,384 PPR	4,096 CPR / 16,384 PPR
<b>Fieldbus</b>	CANopen / Modbus RTU	CANopen / Modbus RTU

# Motors with controller

# Plug & Drive Studio

- Precise position, speed, and velocity control
- Magnetic single-turn absolute encoder
- Optionally with battery-free multi-turn absolute encoder
- Simple programming with the Plug & Drive Studio
- Controlled by fieldbus, clock & direction or analog input
- Fast commissioning

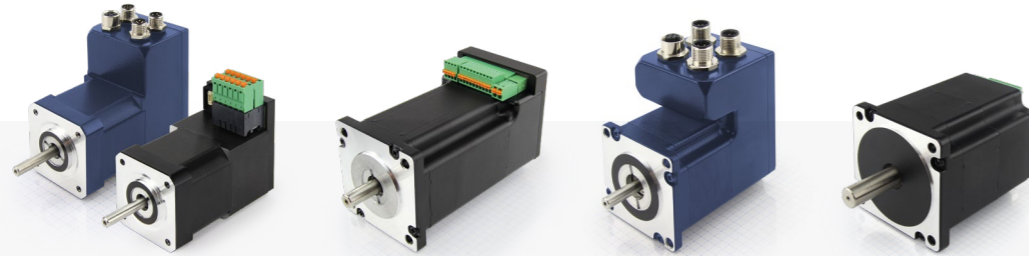

Stepper motors	PD2-C	PD4-C	PD4-E	PD6-C
<b>Size</b>	42 mm	56 / 60 mm	56 / 60 mm	86 mm
<b>Holding torque</b>	50 Ncm	53.7 - 354 Ncm	187 - 354 Ncm	360 - 933 Ncm
<b>Interface</b>	USB	USB	USB	USB
<b>Fieldbus</b>	CANopen	CANopen	CANopen EtherCAT EtherNet/IP Modbus TCP Modbus RTU	CANopen

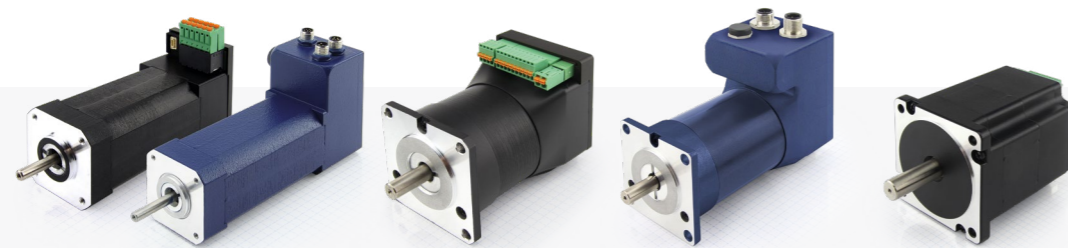

BLDC motors	PD2-CB	PD4-CB	PD4-EB	PD6-CB
<b>Size</b>	42 mm	56 mm	56 mm	80/86 mm
<b>Rated power</b>	105 W	135 W	220 W	534 / 220 W
<b>Rated speed</b>	4,000 rpm	3,500 rpm	3,500 rpm	3,000 rpm
<b>Peak torque</b>	up to 75 Ncm	up to 92 Ncm	up to 180 Ncm	up to 500 Ncm
<b>Interface</b>	-	USB	USB	USB
<b>Fieldbus</b>	CANopen	CANopen	CANopen EtherCAT EtherNet/IP Modbus TCP Modbus RTU	CANopen

**Plug & Drive Studio 3** is a free software to commission and program Nanotec's motor controllers. It comes with an integrated UI Designer which enables users to adapt the interface to different types of applications and user groups.

- Intuitive operating concept and user guidance
- User-friendly motor tuning through oscilloscope functions
- Quick configuration of application-specific parameters
- Effective analysis of the operating states
- Easy creation of sequence programs using the new app generator
- Integrated programming environment for NanoJ (C++ based real-time programming)
- Supports CANopen, EtherCAT, Profinet, Modbus (RTU and TCP) and Ethernet (REST)

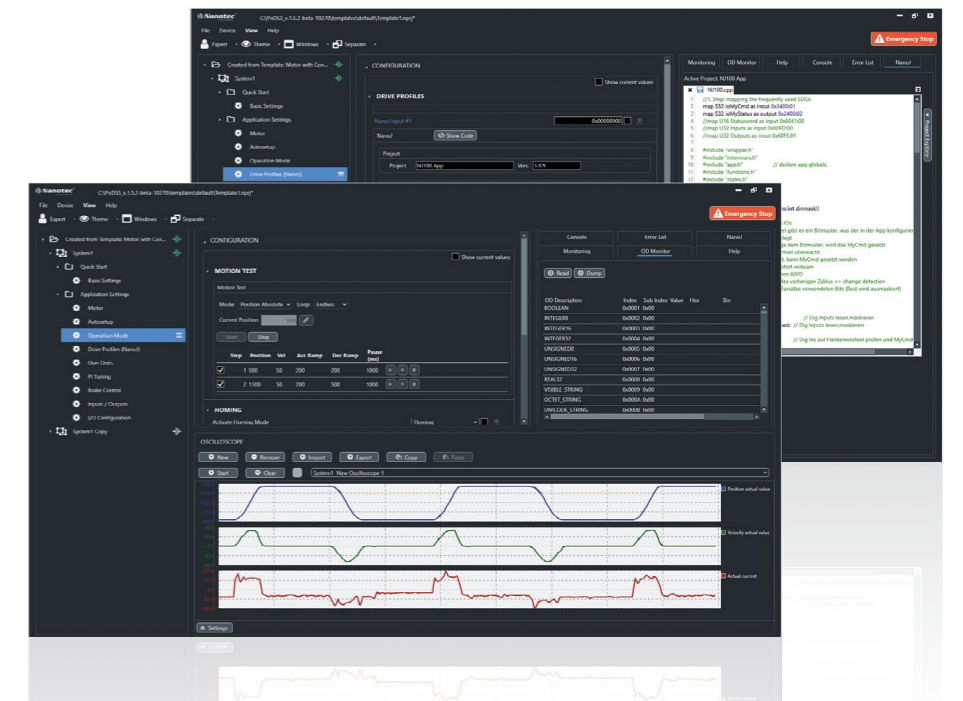

# NanoLib – Software integration for motor controllers

The **NanoLib** software library facilitates the integration of Nanotec's motor controllers into existing software applications. It is ready to use and contains all functionalities to communicate with controllers via CANopen, EtherCAT, Profinet, Modbus (RTU and TCP) and the Ethernet (REST) protocol. NanoLib helps to control motors, update the firmware and upload NanoJ programs. The library supports the programming languages C++, C# and Python.



# Plug-in-controllers

The **CPB** motor controllers are designed for integration in customer applications and customized boards produced in medium and high quantities. The plug-in controllers significantly reduce space and cabling requirements – an advantage that comes into full effect in multi-axis controllers.

- For brushless DC and stepper motors
- Field-oriented control with encoder, Hall sensors or sensorless
- Precise position, speed and velocity control
- CANopen, EtherCAT, EtherNet/IP, Modbus TCP, Modbus RTU (RS485)
- Simple configuration and programming with NanoJ V2
- Controlled by fieldbus, clock & direction or analog input
- For series projects optionally also with Profinet or EtherNet/IP

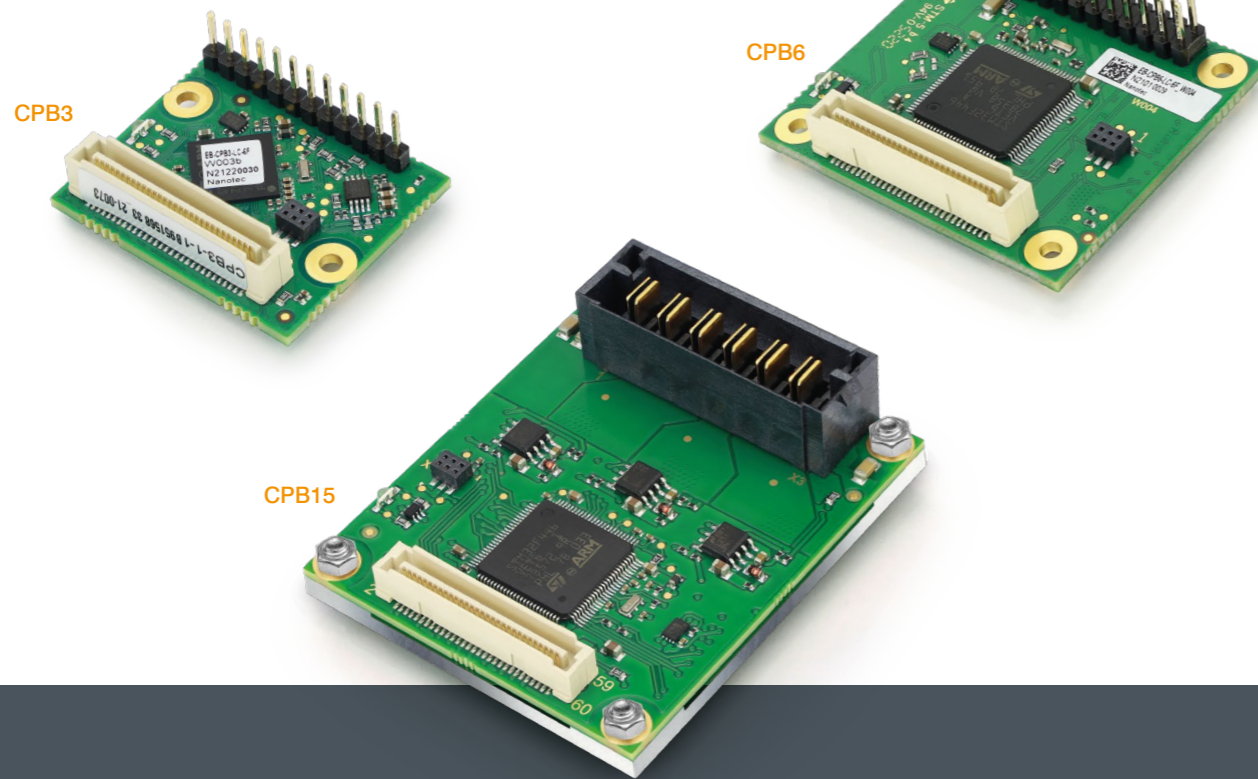

	CPB3	CPB6	CPB15
<b>Motor type</b>	BLDC and stepper motors	BLDC and stepper motors	BLDC motors
<b>Operating voltage</b>	12 - 58 V	12 - 58 V	12 - 58 V
<b>Rated current</b>	3 A	6 A	15 A
<b>Peak current</b>	9 A	18 A	45 A
<b>Fieldbus (with external wiring)</b>	CANopen, EtherCAT, Modbus RTU, Modbus TCP	CANopen, EtherCAT, Modbus RTU, Modbus TCP	CANopen, EtherCAT, Modbus RTU, Modbus TCP
<b>Inputs/outputs (with external wiring)</b>	11 digital inputs/outputs 2 analog inputs 1 brake output 2 encoder inputs	11 digital inputs/outputs 2 analog inputs 1 brake output 2 encoder inputs	11 digital inputs/outputs 2 analog inputs 1 brake output 2 encoder inputs
<b>Dimensions</b>	30 x 36 mm	40 x 45 mm	50 x 60 mm

# High-performance controllers



	N5	C5	C5-E
<b>Operating voltage</b>	12 - 72 V (low current) 12 - 48 V (high current)	12 - 48 V	12 - 48 V
<b>Rated current</b>	10 A (low current) 18 A (high current)	6 A	6 A (low current) 10 A (high current)
<b>Peak current</b>	10 A (low current) 40 A (high current)	6 A	6 A (low current) 30 A (high current)
<b>Interface</b>	-	USB	USB
<b>Fieldbus</b>	CANopen, EtherCAT, EtherNet/IP, Modbus RTU (RS485), Modbus TCP	-	CANopen, EtherCAT, EtherNet/IP, Modbus RTU (RS485), Modbus TCP
<b>Inputs / outputs</b>	6 digital inputs 2 analog inputs 2 digital outputs 1 encoder input 1 brake output	6 digital inputs 1 analog input 2 digital outputs	5 digital inputs 2 analog inputs 3 digital outputs 1 encoder input 1 brake output



	CL3-E	CL4-E	CM-CPB3-44 (4 axes)
<b>Operating voltage</b>	12 - 24 V	12 - 58 V	12 - 58 V
<b>Rated current</b>	3 A	3 A (low current) 6 A (high current)	3 A
<b>Peak current</b>	3 A (low current) 6 A (high current)	6 A (low current) 18 A (high current)	3 A (low current) 9 A (high current)
<b>Interface</b>	USB	USB	USB
<b>Fieldbus</b>	CANopen, Modbus RTU (RS485, RS232)	CANopen, Modbus RTU (RS485)	EtherCAT
<b>Inputs / outputs</b>	5 digital inputs 2 analog inputs 3 digital outputs 1 encoder input	4 digital inputs 1 analog input 2 digital outputs 1 encoder input	4 digital inputs (per axis) 2 digital outputs (per axis) 1 analog input (per axis) 1 brake output (per axis) 2 encoder inputs (per axis)

# Linear actuators

Nanotec's product range includes stepper motor linear actuators in three versions and six sizes. Thanks to their special stator geometry and optimized magnetic materials, the actuators generate considerably more force than comparable drives. They are complemented by matching lead screws with a large selection of leads, diameters and lengths – in standard as well as customized versions. For applications with extremely high demands in terms of service life, all lead screws are also available with DLC coating. It is made of carbon material and improves the friction characteristics, and thus increases the service life of the nuts by approx. 100%.

- Force up to 1,000 N
- Max. speed up to 244 mm/s
- Standard leads of 0.4 to 10.16 mm
- Different types of nuts



## LA – non-captive

- NEMA 8 to 23
- Force up to 1,000 N
- Speed up to 244 mm/s
- Lead screw available separately

## LGA – captive

- NEMA 8 to 23
- Stroke length 12.7 - 63.5 mm
- Force up to 1,000 N
- Speed up to 244 mm/s

## LSA – external

- NEMA 6 to 23
- Force up to 1,000 N
- Speed up to 244 mm/s
- Nut available separately

# Mini linear actuator

The **LSA14** has a flange size of just 14 mm, making it the smallest stepper motor linear actuator from Nanotec. With a maximum force of 15 N, it is primarily used in medical engineering, laboratory automation and optical technology.

- 3.5 mm thread diameter
- With 1 mm or 2 mm lead
- 1.8° step angle

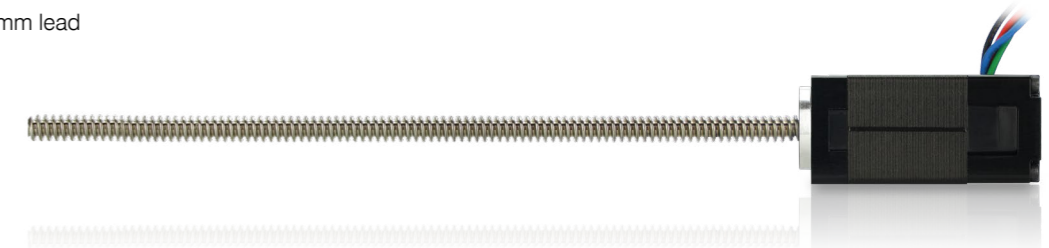

# Linear actuator with controller

The **PSA56** combines Nanotec's LSA56 hybrid linear actuator and the intelligent controllers of the PD4-E series. It is specially designed for demanding applications that require high repeatability. With a resolution of 1,024 CPR, the integrated magnetic single-turn absolute encoder supports field-oriented control. The lead screw is coated with carbon material to improve friction characteristics and increase the service life of the nuts.

- Easy to program
- Robust design, protection class IP65
- Lower installation costs and reduced cabling efforts
- More lead screws and motor lengths available
- Operating voltage: 12 - 48 V DC
- Interface: USB
- Fieldbuses: CANopen, EtherCAT, Modbus RTU and TCP

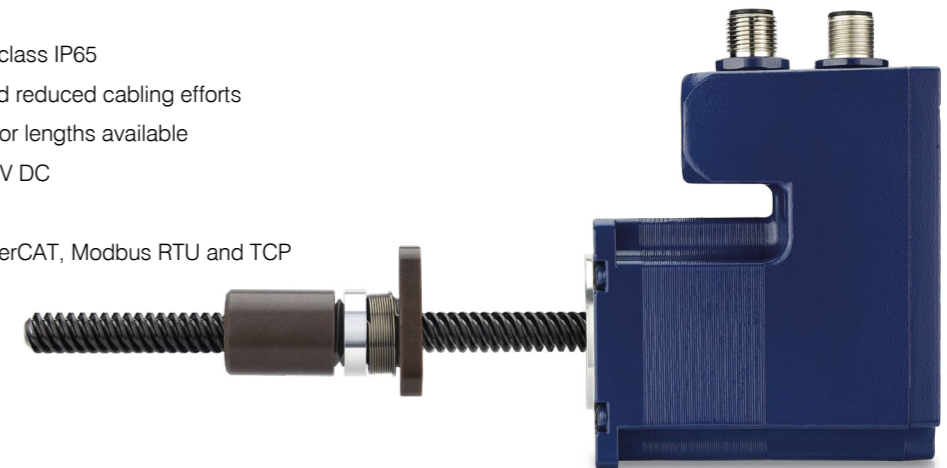

# Threaded nuts

Providing quiet operation and a long service life, Nanotec's standard and anti-backlash nuts are an ideal choice for high-performance motion control applications.



## BLDC linear actuators

The **LBA60** short-stroke actuator is ideal for use in adjustment units of linear systems or for controlling valves. The integrated ball screw extends the motor's service life – even when run at high speeds and loads. With a nominal voltage of 48 V, this compact linear actuator reaches a top speed of 292 mm/s. The built-in encoder ensures accurate positioning.

- 60 mm flange
- Nominal / max. force: 500 N / 1,500 N
- Nominal / max. voltage: 6.2 A / 17.7 A
- Stroke length: 55 mm
- Encoder resolution incremental: 4,096 CPR / 16,384 PPR
- Encoder resolution SSI: 17 Bit
- Optionally with integrated brake



## LPGA60

The **LPGA** version of the short-stroke actuator is equipped with a linear guide that prevents the screw from rotating. Additional mechanical components are not required to ensure precise linear motion and high repeatability.



## High-torque planetary gearboxes

The **GP80** planetary gearboxes come in one- and two-stage versions and with four different reduction ratios. They are fitted with straight-cut hardened gears and can be ordered with square or round flange. Custom-specific modifications are possible as well.

The GP80 gearboxes can be combined with these motors:

- NEMA 34 BLDC and stepper motors
- BLDC motors with 80 mm flange and 14 mm motor shaft
- APBA80 series BLDC motors with 80 mm flange and 19 mm motor shaft
- All DFA90 external rotor motors



## Hollow rotary tables

Equipped with a cross-shaft bearing, the **HRTA** hollow-shaft gearboxes offer high positioning accuracy, excellent runout characteristics and a max. load capacity of 2,000 N. Combining the hollow rotary tables with a stepper motor, results in a rotary actuator that is ideally suited for use with rotary tables, end-of-arm tooling (EOAT) or pick-and-place tools.

- For stepper motors NEMA 17, 23/24
- Lifetime: 20,000 h
- Max. gear backlash: 1'
- High efficiency



## Internal rotor motors

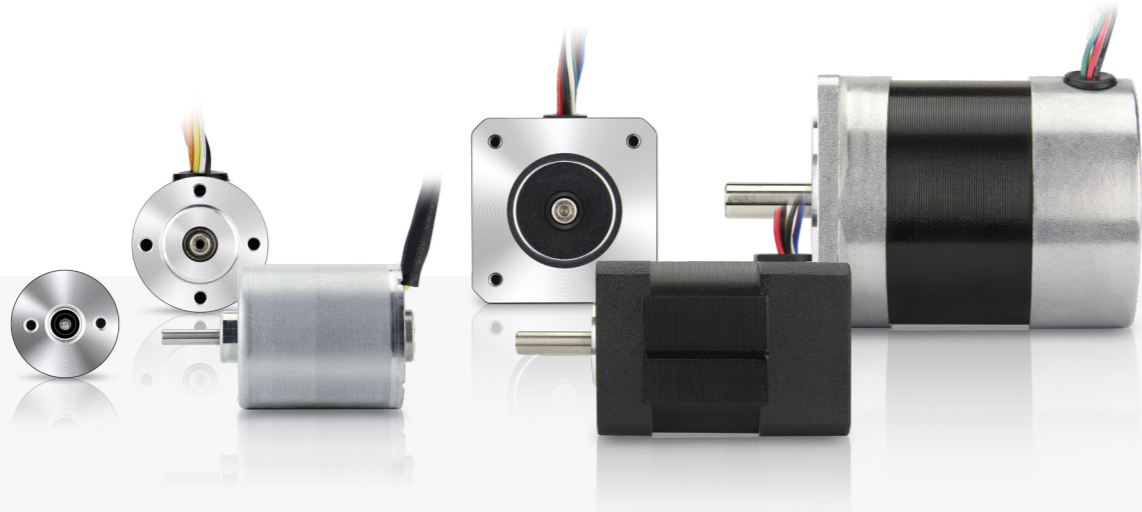

	DB22	DB28	DBL36	DB43	DB59	DB80
<b>Size</b>	Ø 22 mm	Ø 28 mm	Ø 36 mm	42 mm	56 mm	80 mm
<b>Rated voltage</b>	24 V	15 - 24 V	24 V	24 - 48 V	24 - 48 V	48 V
<b>Rated power</b>	4 - 7.7 W	15 - 24 W	7.5 - 33 W	53 - 138 W	84 - 220 W	283 - 942 W
<b>Peak torque</b>	2.4 - 5 Ncm	1.5 - 15 Ncm	4.5 - 21 Ncm	51 - 132 Ncm	69 - 180 Ncm	250 - 850 Ncm
<b>Rated torque</b>	0.8 - 2.2 Ncm	0.5 - 5 Ncm	1.5 - 7 Ncm	17 - 44 Ncm	23 - 60 Ncm	90 - 300 Ncm
<b>Rated speed</b>	3,500 - 4,800 rpm	4,000 - 10,000 rpm	4,500 - 4,800 rpm	3,000 rpm	3,500 rpm	3,000 rpm

## Stepper motors

The **ASA56** high-torque stepper motor is rated IP65 (IP54 at the shaft output) and provides high electromagnetic compatibility (EMC). The encoder is already integrated – two types are available: multi-turn or incremental. Larger quantities of the ASA56 can also be ordered with an integrated holding brake.

- Flange size: NEMA 23 (56 mm)
- Holding torque: 140 – 230 Ncm
- Incremental resolution: 4,096 CPR / 16,384 PPR
- SSI resolution: 16 Bit multi-turn / 17 Bit single-turn
- Shortly with UL / CSA certification



## External rotor motors

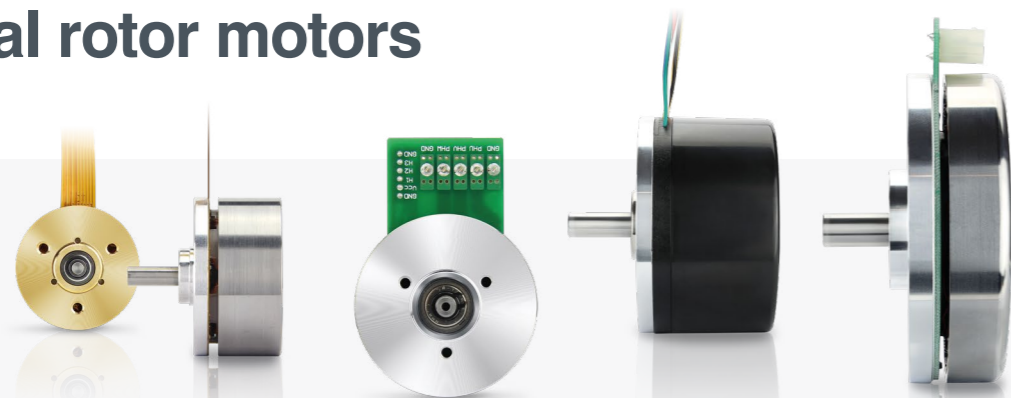

	DF20	DF32	DF45	DFA68	DFA90
<b>Size</b>	Ø 20 mm	Ø 32 mm	Ø 45 mm	Ø 68 mm	Ø 90 mm
<b>Rated voltage</b>	12 V	24 V	24 V	24 V	24 - 48 V
<b>Rated power</b>	5 W	7.4 W	30 - 65 W	106 - 110 W	130 - 170 W
<b>Peak torque</b>	1.9 Ncm	7.65 Ncm	15 - 39 Ncm	87 Ncm	150 - 300 Ncm
<b>Rated torque</b>	0.76 Ncm	2.55 Ncm	5 - 13 Ncm	29 Ncm	45.7 - 96.4 Ncm
<b>Rated speed</b>	5,170 rpm	2,760 rpm	4,840 - 5,260 rpm	3,500 - 3,700 rpm	1,670 - 2,720 rpm

DF45, DFA68 and DFA90 are also available with an integrated 3-channel encoder with a resolution of 4,096 CPR.

## Spring-loaded brakes

The **BCD** brakes are designed as holding brakes for BLDC and stepper motors. They come with a shaft and a flange and are mounted onto the front of the motor. These spring-loaded brakes are ideal for applications where the motor needs to be held in position when power is disengaged. The brakes release and the shaft rotates freely again when 24 V is applied. Four sizes match a wide range of motor flanges.

- Holding torque: 0.4 – 5.0 Nm
- Rated power: 6.9 – 13.5 W
- Very little rotary play
- No auditory noise



# Wheel drives

The **WD** wheel drives consist of a wheel, integrated planetary gearbox and bearing in one short unit. The combination of Nanotec's wheel drives and motors results in compact systems that simplify the development and production of self-propelled systems, such as service robots or Automated Guided Vehicles (AGVs).

- Space-saving design
- Withstands high radial loads
- 6 different wheel diameters
- Few components minimize cabling effort

The WD wheel drives are also available with a premounted motor brake for applications that require repeated and dynamic braking.



	Ø (mm)	Height (mm)	Width (mm)	Payload (kg)	Reduction	Rated torque gearbox (Nm)	Matching motors
<b>WD10030</b>	100	105	30	400	16	24.6	NEMA 23/24
<b>WD14050</b>	140	150	50	400	11 / 16 / 20 / 26	19.2 / 24.6 / 28.6 / 29.1	NEMA 23/24 / DB80 / DFA90
<b>WD15050</b>	150	160	50	400	11 / 16 / 20 / 26	19.2 / 24.6 / 28.6 / 29.1	NEMA 23/24 / DB80 / DFA90
<b>WD16050</b>	160	170	50	400	11 / 16 / 20 / 26	19.2 / 24.6 / 28.6 / 29.1	NEMA 23/24 / DB80 / DFA90
<b>WD18050</b>	180	190	50	400	11 / 16 / 20 / 26	19.2 / 24.6 / 28.6 / 29.1	NEMA 23/24 / DB80 / DFA90
<b>WD20050</b>	200	210	50	400	11 / 16 / 20 / 26	19.2 / 24.6 / 28.6 / 29.1	NEMA 23/24 / DB80 / DFA90

# Integrated wheel drives

The **WD42** wheel drive was developed for a customer application. The super-compact unit consists of a wheel, gearbox, brushless DC motor and encoder. By integrating all components directly at the wheel, the drive has an overall length of just 103 mm. Wheel diameters range from 75 to 140 mm. For maintenance the wheels can be easily changed.



	Ø (mm)	Payload (kg)	Reduction	Rated torque (Nm)	Rated speed (m/s)
<b>WD07530-4212</b>	75	200	12	4.9	1.2
<b>WD07530-4215</b>	75	200	15	6.4	0.9
<b>WD07530-4226</b>	75	200	26	10.6	0.5
<b>WD14030-4212</b>	140	200	12	4.9	2.2
<b>WD14030-4215</b>	140	200	15	6.4	1.7
<b>WD14030-4226</b>	140	200	26	10.6	1.0

# Modular wheel drives

Nanotec's DFA90 external rotor motor with integrated encoder and the 200 mm **WD** wheel drive are a perfect match. The total installation length of this combination is 121.5 mm.



<b>Voltage</b>	48 V
<b>Reduction</b>	10.84
<b>Diameter</b>	200 mm
<b>Payload</b>	400 kg
<b>Rated torque</b>	9.8 Nm
<b>Rated power</b>	158 W



## Encoders

Equipped with an SSI interface, the **NMM1** magnetic absolute encoder offers a resolution of 17 Bit single-turn and 16 Bit multi-turn. Two shaft diameters are offered.

- For motors with flange size NEMA 17 - 23
- Maintenance-free because no battery or gearbox required
- Robust, low-wear and insensitive to dust

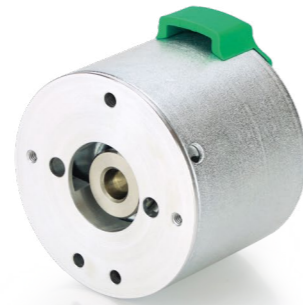

The high resolution of the **NME2** encoder allows for very accurate positioning and excellent velocity control at low speeds. It is available for incremental signals as well as with an SSI interface.

- Incremental resolution: 4,096 CPR / 16,384 PPR
- SSI resolution: 17 Bit, single-turn absolute
- For motors with a flange size  $\geq 42$  mm and a maximum shaft diameter of 15 mm



The compact **NME3** encoder is offered both with incremental interface including commutation signals for BLDC motors and with serial SSI interface. It can be combined with a wide range of brushless DC motors and stepper motors starting from size NEMA 8.

- Incremental resolution: 500 – 4,096 CPR
- SSI resolution: 16 Bit
- Max. speed: 30,000 U/min
- For shaft diameters 4 mm, 5 mm and 6.35 mm



## Brake chopper

The **BC72-50** brake chopper module limits the voltage in an intermediate circuit to a safe level, thus protecting all controllers in the circuit from overvoltage. The energy generated by the decelerating motor first loads the integrated buffer capacitor, then the remaining energy is converted to heat by switching it to a braking resistor.

- Switching voltage adjustable in 1 V steps
- Integrated brake resistor
- Connection of an external resistor possible
- 20 W rated power
- 12 - 75 V DC operating voltage



## Fieldbus converter

Converters enable Nanotec's motor controllers or brushless DC motors with integrated controller to exchange data with a PC.

The **ZK-USB-CAN-1** sets up a connection between the USB interface of the PC and a CANopen interface. The **ZK-USB-RS485-1** connects the PC and the RS485 communication interface of the controller.







Nanotec Electronic GmbH & Co. KG  
Kapellenstraße 6, 85622 Feldkirchen  
T +49 (0)89 900 686-0  
info@nanotec.de  
[www.nanotec.com](http://www.nanotec.com)

© 2024 Nanotec Electronic GmbH & Co. KG. All rights reserved. 01.2024 (AB)

